

**MOEBIUS**  
**Sales Program**

**H. MOEBIUS & FILS**

Hegenheimerstrasse 23  
CH-4123 Allschwil 1/BL

Phone (061) 63 40 00  
Telex 62717

## History of H. Moebius & Fils Manufacturers of Lubricants for Watches and Fine Mechanics

In 1855, the watch-maker Hermann Moebius started making oils for watches in Hannover.

H. Moebius & Fils owe it to his enterprising spirit and the continued dedication of his descendants that they occupy today the foremost position in the world in the field of lubricants for watches and fine mechanics.

In the following is a short summary of the outstanding events which occurred since the foundation of the company more than 120 years ago:

- |           |  |
|-----------|--|
| 1855      | Foundation of the company in Hannover (Germany) by the watch-maker Hermann Moebius. He was the first to discover the excellent properties of neats foot oil in the lubrication of watches. It was also he himself who in the following years produced the most valuable oils on this basis.  |
| 1855–1890 | During this period the Moebius oils already attained international renown and their excellent quality was confirmed by numerous awards won at important fairs in Germany and abroad.   |
| 1892      | Establishment of the subsidiary H. Moebius & Fils in Basle (Switzerland) which later on took over the industrial production and worldwide distribution of their products.  |
| 1892–1950 | These years were dedicated mainly to the perfection of quality and increase in variety of the products range.  |
| 1951      | Production plant and distribution were shifted to Allschwil, Basle Country, the present location of the company.   |
| 1952      | Many years of joint research with the Swiss Horological Institute in Neuchâtel resulted in the development of the well-known oil Moebius SYNT-A-LUBE. This fully synthetic oil occupies an outstanding position in the history of lubrication. Even 25 years after its first appearance it is still the oil most in demand all over the world. |
| 1970      | Development of the Moebius oils for plastics. Thanks to the considerable improvement in performance achieved with the use on plastics, these lubricants find an ever increasing range of applications.   |
| 1971      | Marketing of a vast range of lubricants precisely adapted to the requirements of fine mechanics. The final result – so far – of these endeavours is a product range consisting of 13 groups, well-known under the name MICROGLISS.   |
| 1973      | Practical tests made with the first samples of a newly developed epilame on the basis of plastics. Thanks to its outstanding qualities, this product for surface treatment known under the trade name of FIXODROP BS has in the meantime been well introduced and acclaimed on the market.   |



## MOEBIUS Today

The product range comprises far more than hundred lubricants and auxiliary agents, including

- synthtetic oils
- classic oils and greases
- silicon oils and greases
- anti-corrosive oils
- anti-corrosive agents
- epilames
- various specialities

Beside their original main application in the watch industry, Moebius lubricants find an ever increasing variety of uses in fine mechanics, such as:

- photography and camera industry
- optics
- telephones
- control devices
- meters (gas, water, electricity)
- parking meters, time switches
- speedo- and tachometers
- board instruments in cars, ships, aircrafts
- technical instruments for medical use
- certain military applications
- record players, tape recorders
- miniature ball bearings
- technical precision toys
- mechanical parts of computers
- office machines

## Synthetic Oils

Product No.	Viscosity in cSt at 0°C	Viscosity in cSt at 20°C	Temperature range —/+ in °C	Lubricating effect (Oiliness)	Adherence	Ageing stability	Pressure resistance	Compatibility with Plastics	Trade name Field of application Remarks
9010	450	120	32/70						SYNT-A-LUBE. For escapements and jewel bearings of small to medium calibres.
9013	530	123	32/70						as 9010, with MoS <sub>2</sub>
9014	390	98	35/70						as 9010, lower viscosity
9015	450	120	32/70						SYNT-A-LUBE SAO. For lubrication of plastics
9020	1450	270	18/80						SYNTA VISCO LUBE. For larger calibres and increased pressures
9023	1500	265	18/80						as 9020, with MoS <sub>2</sub>
9024	1450	260	18/80						SYNTA VISCO LUBE SAO. For the lubrication of plastics
9025	1500	270	18/90						as 9024, for higher temperatures
9026	1800	290	18/90						as 9024 and 9025, with MoS <sub>2</sub>
9027	7600	1060	7/80						for plastics and for more strain
9030	180	60	41/60						SYNTA FRIGO LUBE. As 9010, for lower temperatures
9033	240	70	41/60						as 9030, with MoS <sub>2</sub>
9034	180	60	41/60						SYNTA FRIGO LUBE SAO. For use with plastics at low temperatures
9040	65	24	52/120						MOEBIUS ARCTIC. Oil for low temperatures
941	340	104	15/70						SPECIAL OIL «HO». For jewels

### Microgliss Group N

N/11	470	120	32/70						These oils are based on the products 9010, 9014, 9020 and 9030. The addition of an organic molybdenum compound makes these oils somewhat more pressure resistant as compared with the basic oils.
N/114	395	100	34/70						
N/21	1400	270	18/80						
N/31	200	60	42/60						

Our most important synthetic oils are available also in the following colours: 9010/blue, 9020/red, 9030/green, in container sizes of 46 cc and larger.

Remarks For synthetic and classic oils the temperatures indicated in the lower reaches correspond to a viscosity of 10 000 cSt. In the watch industry this viscosity is generally regarded as limit.  
The temperatures in the upper reaches may be exceeded for short periods by about 20°C.



Product No.	Viscosity in cSt at 0°C	Viscosity in cSt at 20°C	Temperature range —/+ in °C	Lubricating effect (Oiliness)	Adherence	Ageing stability	Pressure resistance	Compatibility with Plastics	Trade name Field of application Remarks
8000	280	95	15/80	●	●	◐	◐	◐	Movements in the range from watches to alarm clocks. Not for winding mechanism and spring
8030	440	115	18/80	◐	◐	◐	◐	◐	Pendulum clocks, musical clocks, time switches
8031	390	110	25/80	◐	◐	◐	◐	◐	as 8030, for lower temperatures
8034	360	110	18/80	◐	◐	◐	◐	◐	as 8030, with graphite
8035	260	84	25/80	◐	◐	◐	◐	◐	as 8031, lower viscosity than 8031
8036	430	125	18/80	◐	◐	◐	◐	◐	as 8030, with MoS <sub>2</sub>
8040	570	145	27/80	◐	◐	◐	◐	◐	Movements in the range from cuckoo clocks to tower clocks
8041	280	74	27/80	◐	◐	◐	◐	◐	as 8040, lower viscosity. Surface treatment recommended
8042	700	170	27/80	◐	◐	◐	◐	◐	as 8040, with graphite
8043	570	170	27/80	◐	◐	◐	◐	◐	as 8040, with MoS <sub>2</sub>
8050	98	34	35/60	◐	◐	◐	◐	◐	Oil for low temperatures
8060	1800	340	16/80	◐	◐	◐	◐	◐	Pivots of large clocks. Higher viscosity than 8040
8062	1150	278	23/80	◐	◐	◐	◐	◐	as 8060, with MoS <sub>2</sub>
8141	11000	1250	4/100	◐	◐	◐	◐	◐	For high pressure problems in cup screws, center wheels and barrel arbors
8142	3400	643	11/100	◐	◐	◐	◐	◐	as 8141, with high MoS <sub>2</sub> content
8143	2400	460	12/100	◐	◐	◐	◐	◐	Pure, stabilized mineral oil for fine mechanics
8145	3000	550	12/100	◐	◐	◐	◐	◐	as 8143
8146	5800	1050	5/100	◐	◐	◐	◐	◐	as 8141, with low MoS <sub>2</sub> content



## Classic Oils of the Microgliss Program

Product No.	Viscosity in cSt at 0°C	Viscosity in cSt at 20°C	Temperature range —/+ in °C	Lubricating effect (Oiliness)	Adherence	Ageing stability	Pressure resistance	Compatibility with Plastics	Trade name Field of application Remarks
A/1	85	30	38/80						<p><b>Microgliss Group A</b></p> <p>9 stabilized mineral oils for simple lubricating problems under little strain.</p> <p>For sewing machines, electric motors, bicycles, ball bearings.</p>
A/2	132	40	35/80						
A/3	260	71	34/80						
A/4	550	125	26/80						
A/5	1300	230	18/100						
A/6	1800	320	14/100						
A/7	2400	460	12/120						
A/8	4700	800	7/120						
A/9	14000	1900	3/120						
B/1	110	37	40/80						<p><b>Microgliss Group B</b></p> <p>9 stabilized mineral oils with the addition of finely dispersed micro-fine MoS<sub>2</sub> which does not settle even after long storage. The oils of this group are suitable for long-term lubrication under more strain.</p> <p>Fields of application as for Group A.</p>
B/2	150	46	35/80						
B/3	305	82	33/100						
B/4	570	128	26/100						
B/5	1050	215	19/100						
B/6	1450	270	18/120						
B/7	2000	390	15/120						
B/8	4200	740	7/120						
B/9	10000	1500	0/120						



Product No.	Viscosity in cSt at 0°C	Viscosity in cSt at 20°C	Temperature range —/+ in °C	Lubricating effect (Oiliness)	Adherence	Ageing stability	Pressure resistance	Compatibility with Plastics	Trade name Field of application Remarks
C/1	93	34	36/60						<p><b>Microgliss Group C</b></p> <p>9 oils on mineral basis. Their adherence and lubricating qualities have been improved by the addition of a fatty oil.</p> <p>Their range of application reaches from the lubrication of micro motors to the solution of special problems in the watch industry — such as cup screws and center wheels.</p>
C/2	140	44	34/60						
C/3	280	78	33/70						
C/4	550	125	26/70						
C/5	800	180	23/80						
C/6	1250	255	19/80						
C/7	2600	355	15/100						
C/8	2900	490	13/100						
C/9	11000	1250	+4/+100						
D/1	87	32	33/60						<p><b>Microgliss Group D</b></p> <p>5 oils derived from Group C, containing a high pressure additive on organic molybdenum basis. These oils are suitable for use under high to extreme pressures.</p>
D/2	260	73	30/70						
D/3	900	193	22/80						
D/4	1900	370	15/80						
D/5	7300	1200	3/80						
L/1	120	39	35/60		—				<p><b>Microgliss Group L</b></p> <p>5 oils derived from Group D containing an anti-corrosive agent and a film-forming additive for the use in the dipping process. For high and extreme strain in mechanisms which are exposed to adverse weather conditions.</p>
L/2	300	82	33/70		—				
L/3	1100	220	20/80		—				
L/4	2050	400	14/80		—				
L/5	7000	1200	3/80		—				

## Classic Oils of the Microgliss Program

Product No.	Viscosity in cSt at 0°C	Viscosity in cSt at 20°C	Temperature range —/+ in °C	Lubricating effect (Oiliness)	Adherence	Ageing stability	Pressure resistance	Compatibility with Plastics	Trade name Field of application Remarks
E/1	105	38	33/60						<p align="center"><b>Microgliss Group E</b></p> <p>9 oils which are similar in their composition to Group C but which have an improved lubricating action.</p> <p>For fine mechanics in general.</p> <p>In the watch industry the oils of this group are applied for alarm clocks, wall clocks und musical clocks.</p>
E/2	145	46	33/60						
E/3	280	74	30/70						
E/4	430	110	27/70						
E/5	570	145	25/80						
E/6	900	200	20/80						
E/7	1150	260	18/80						
E/8	2000	420	10/80						
E/9	4100	780	8/80						
F/1	145	50	25/60						<p align="center"><b>Microgliss Group F</b></p> <p>6 stabilized oils with good, in case of No. 6 even excellent, lubricating qualities.</p> <p>For fine mechanics in general. In the watch industry these oils are applied for alarm clocks, meters and pendulum clocks. No. 6 is also suitable for the gear train and the escapement of watches.</p>
F/2	240	77	22/70						
F/3	440	115	18/80						
F/4	650	170	15/80						
F/5	1200	300	12/80						
F/6	280	95	15/80						
G/1	98	34	35/60						<p align="center"><b>Microgliss Group G</b></p> <p>5 oils which correspond to those of Group F. However, they contain a specially cold refined neats foot oil.</p> <p>Fields of application same as for Group F, but in the low temperature range.</p>
G/2	240	77	32/70						
G/3	390	110	26/80						
G/4	650	170	22/80						
G/5	1200	300	16/80						



## Silicon Oils of the Microgliss Program

Product No.	Viscosity in cSt at 0°C	Viscosity in cSt at 20°C	Temperature range —/+ in °C	Lubricating effect (Oiliness)	Adherence	Ageing stability	Pressure resistance	Compatibility with Plastics	Trade name Field of application Remarks
H/1	5,3	3,7	100/50						<p style="text-align: center;"><b>Microgliss Group H</b></p> <p>13 dimethyl silicones with limited possibilities for application as lubricants. However, thanks to their excellent oxidation stability they can be used, inter alia, as bath solutions in thermostats, or as sealing agents due to their hydrophobe properties.</p> <p>The types H/9 through H/13 are used in particular as sealing agents and in case of damping problems.</p>
H/2	8,4	5,8	70/50						
H/3	17,5	11,2	70/60						
H/4	50	32	50/80						
H/5	82	53	50/100						
H/6	170	112	50/100						
H/7	320	220	40/120						
H/8	850	550	40/120						
H/9	1650	1100	40/120						
H/10	17000	11000	0/120						
H/11	60000	37000	0/120						
H/12	110000	70000	0/120						
H/13	180000	110000	0/120						
I/1	175	85	55/250						<p style="text-align: center;"><b>Microgliss Group I</b></p> <p>5 high class silicon oils which differ substantially from the dimethyl silicones of Group H and which also possess superior lubricating qualities.</p> <p>Type I/1 is a chlorophenyl silicon, type I/2 a phenyl-methyl silicon and types I/3 through I/5 are fluor silicones.</p>
I/2	1680	500	18/260						
I/3	1070	370	40/200						
I/4	3900	1280	35/200						
I/5	40000	13000	25/200						

## Anti Corrosive Oils of the Microgliss Program

Product No.	Viscosity in cSt at 0°C	Viscosity in cSt at 20°C	Temperature range —/+ in °C	Lubricating effect (Oiliness)	Adherence	Ageing stability	Pressure resistance	Compatibility with Plastics	Trade name Field of application Remarks
K/1	100	33	38/80		—				<p><b>Microgliss Group K</b></p> <p>5 anticorrosive oils with good lubricating properties under normal strain and good corrosion impeding properties in the presence of saline water. They are particularly suitable for use in the dipping process. They are applied for a large variety of mechanisms which are exposed to adverse weather conditions.</p>
K/2	330	83	34/80		—				
K/3	1400	250	18/100		—				
K/4	2400	460	12/120		—				
K/5	12500	1750	3/120		—				
M/1	—	1,43	—	—	—	—	—	—	<p><b>Microgliss Group M</b></p> <p>The first three products of this group are anticorrosive agents which leave a protective film on the surface after evaporation of the solvent. They differ with respect to the anticorrosive film, which increases in thickness with the number. Product No. M/5 forms a thicker film than No. M/4. The oil No. 6 affords an anticorrosive protection equal to that of oil No. 5, it is, however, based on a more viscous oil. The oil No. 7 has superior lubricating qualities as compared with No. 6. The oils No. 1 to 3 are used to protect parts in storage while the oils No. 4 through 7 are applied for a large variety of mechanisms, like Group K.</p>
M/2	—	1,45	—	—	—	—	—	—	
M/3	—	1,33	—	—	—	—	—	—	
M/4	107	38	38/80		—				
M/5	—	3,5	38/80		—				
M/6	6,6	4,5	18/100		—				
M/7	420	140	18/80		—				
<b>Epilame (Agents for Surface Treatment)</b>									
8900	—	—	—	—	—	—	—		ARETOL. Epilame on the basis of stearic acid and with toluene as solvent.
8911	—	—	—	—	—	—	—		FIXODROP BS CONCENTRATE
3922	—	—	—	—	—	—	—		FIXODROP BS DILUTED
The active substance of Fixodrop BS is a fluorinated plastic with a fluorhydrocarbon as solvent.									



Product No.	Consistance at 20°C	Temperature range —/+ in °C	Lubricating effect (Oiliness)	Adherence	Ageing stability	Pressure resistance	Compatibility with Plastics	Trade name Field of application Remarks
8200	semi liquid	40/80						LUBRIFIANT MOEBIUS. For springs and slowly moving parts with large friction areas.
8201	semi liquid	40/80						as 8200, with MoS <sub>2</sub> , usually applied cold
8203	thixotrope	40/80						as 8200, gelatinous, not to be applied warm
8207	semi liquid	40/80						as 8200, with graphite
8211	solid	40/80						as 8200, but more solid
8212	soft	40/80				—		GLISSALUBE B. For aluminium barrel walls Weak braking action
8213	solid	40/80				—		GLISSALUBE A. For brass barrel walls Good braking effect
8217	very soft	40/80				—		GLISSALUBE 20. Braking grease for barrels
8218	thin, liquid	50/60						as 8200, thinner than 8200
8219	malleable	40/80				—		GLISSALUBE 300. For barrels. Higher onctuosity than 8212, 8213
8221	thin, liquid	50/60						as 8200, with MoS <sub>2</sub>
8222	very thin, liquid	50/60						as 8200. Suitable for Hormec oiler
8223	very thin, liquid	40/80						as 8200, diluted with petrol for the cold dipping lubrication process. Flash point 39°C
8300	solid	40/80						MOEBIUS REMONTOIR GRAESE. For winding mechanisms and springs
8301	solid	40/80						as 8300, with graphite
8302	solid	40/80						as 8300, with MoS <sub>2</sub>
8303	soft	40/80						GREASE WBE 433. Thinner and higher onctuosity than 8300
8320	solid	40/100						Braking grease with strong braking action and good damping effect
8513	solid	60/150	—					Silicon sealing grease
8514	very soft	60/120						Heat resistant grease for fine mechanics and optics. Non-dripping
8516	soft	60/120	—					Silicon sealing grease, softer than 8513
8537	malleable	40/120						For synchronous motors, bearings and high pressures. Melting point 184°C
8541	soft	40/120						For bearings. Melting point above 190°C. Higher penetration than 8537

Note: The lower range of application of greases depends largely on the power reserve of the spring. With sufficient power reserve the temperatures indicated may be lowered accordingly.

# Type of individual lubrication chart adapted to ETA caliber «Gabarit» 11<sup>1</sup>/<sub>2</sub> ” 2850–2879

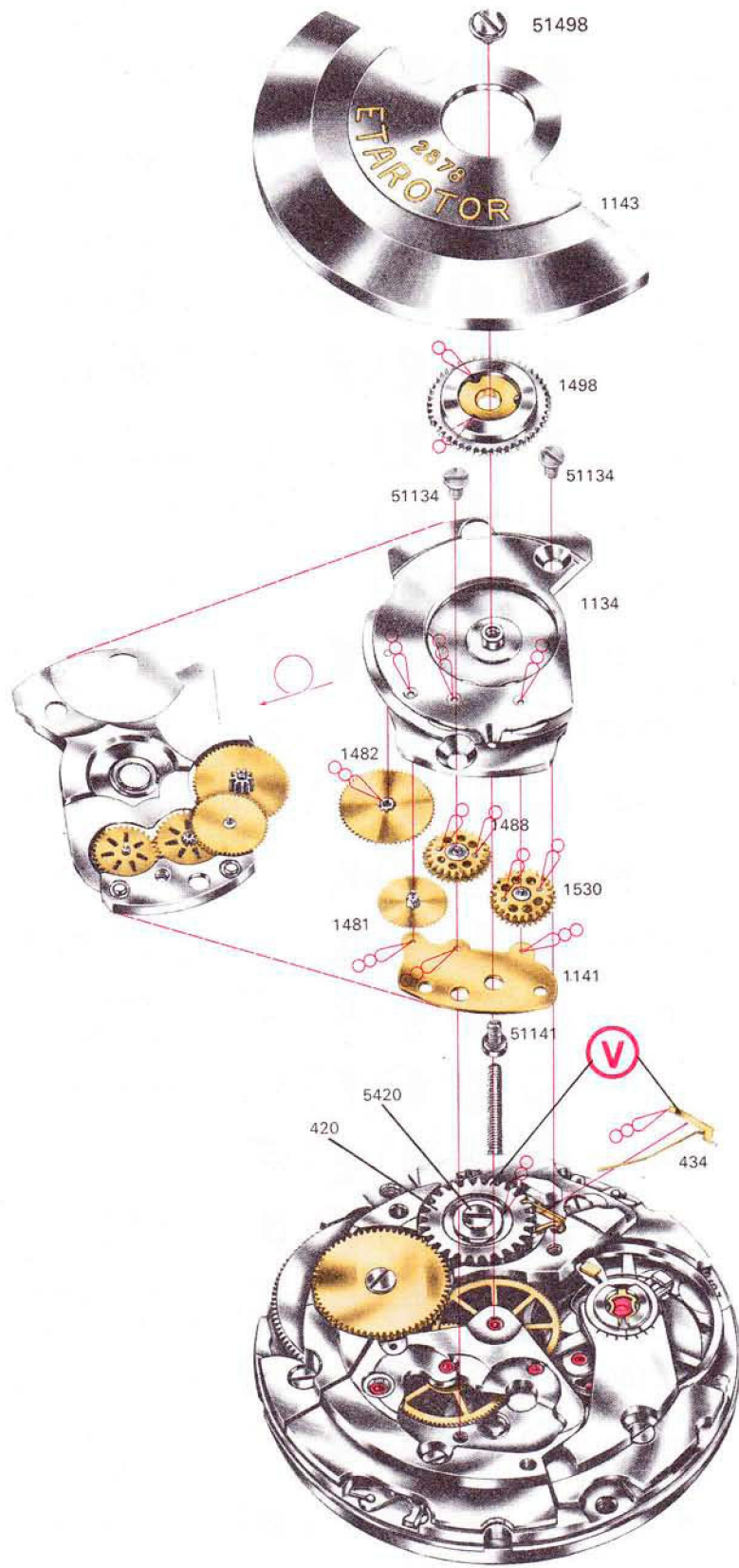

  
Moebius  
SYNT-A-LUBE 9010

  
Moebius  
MICROGLISS D/5  
or Moebius 8141

  
Moebius  
Oil «HO» 941  
or SYNT-A-LUBE 9010  
or SYNTA VISCO LUBE 9020

 Bulk lubrication possible

Moebius  
LUBRICANT 8200  
REMONTOIR GREASE 8300  
LUBRICANT 8223

Prior to assembling it is recommended to coat the pallet stones and the escape wheel with the antispreading agent Moebius Fixodrop BS.

	2870	2872	2878
	2871	2873	2879



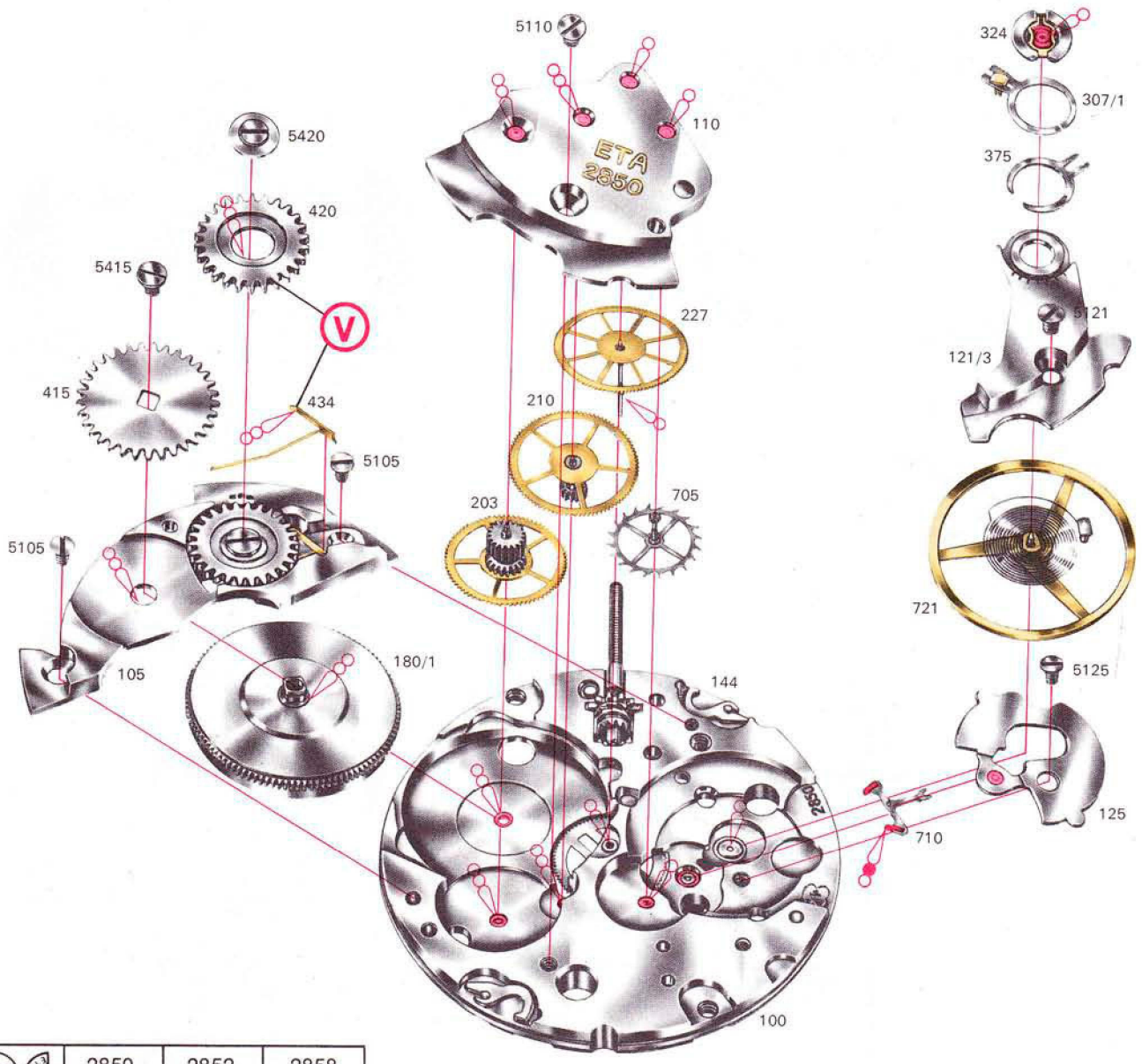

	2850	2852	2858
	2851	2853	2859

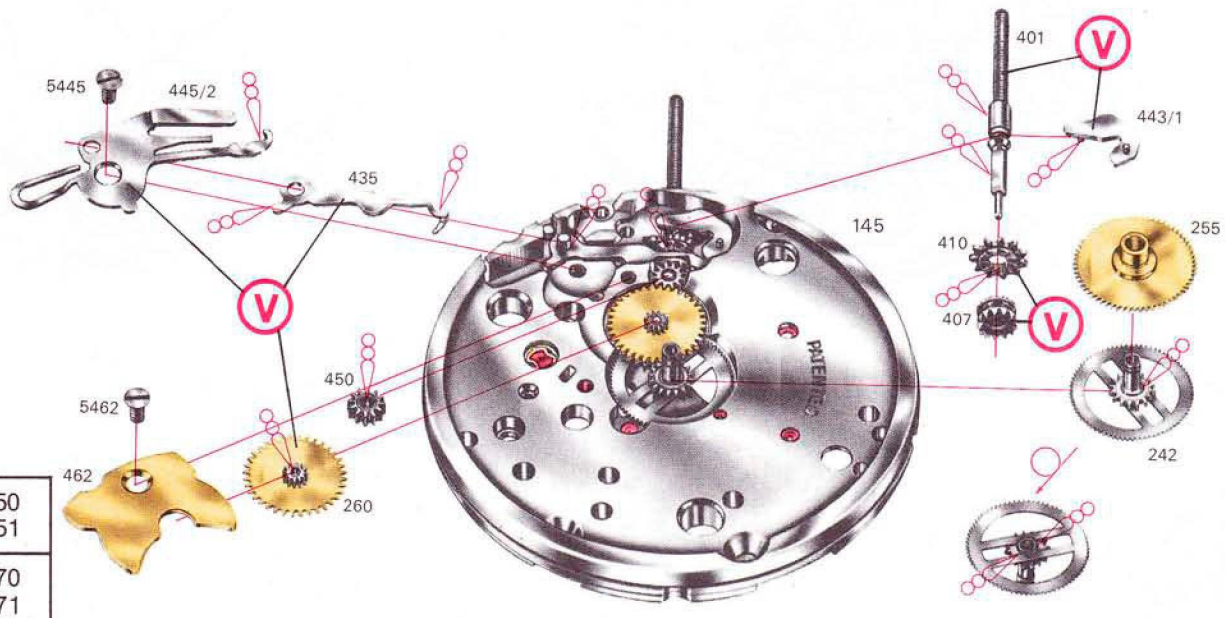

	2850
	2851
	2870
	2871

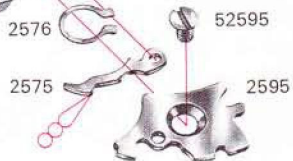
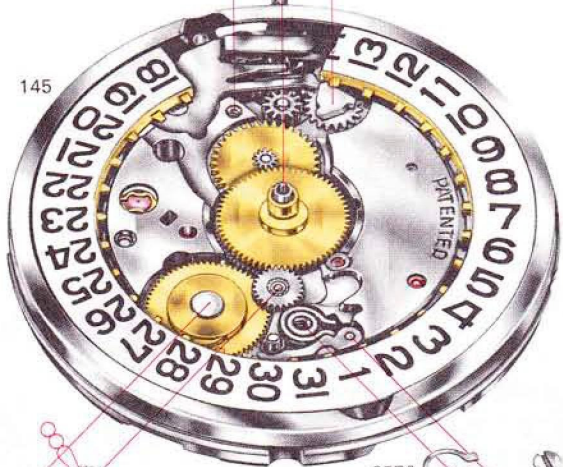
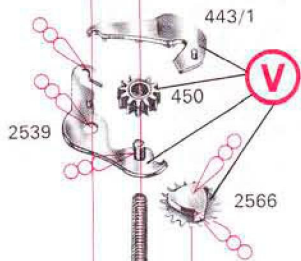
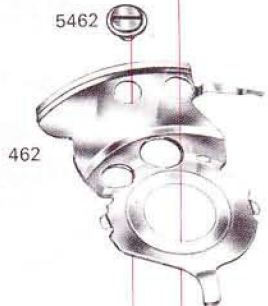
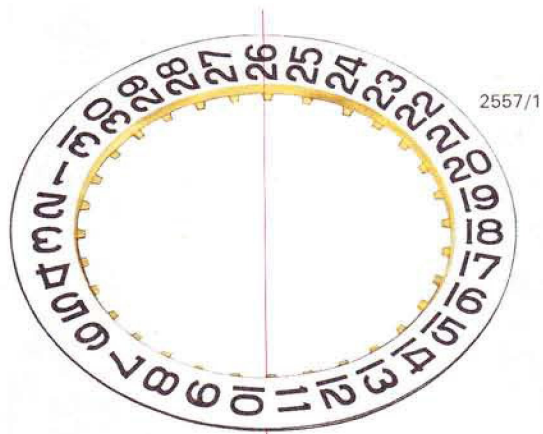

	2852
	2853
	2872
	2873

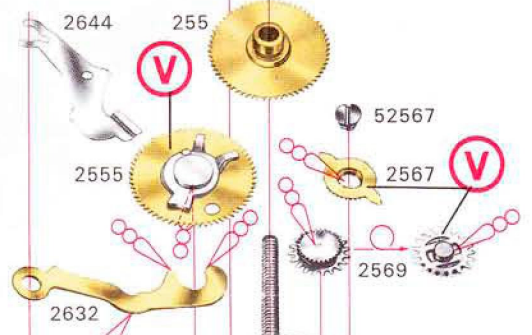
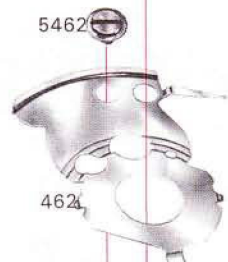
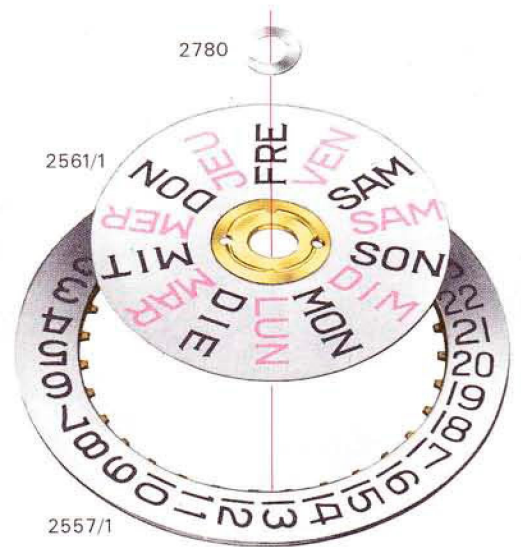

	2858
	2859
	2878
	2879







## Lubrication of Plastics in Fine Mechanics

MOEBIUS products No. 9015, 9024, 9025, 9027 and 9034 are fully synthetic oils (ether alcohols) with a very high oxidation stability and no adverse effects on plastics. They are used for metal/plastic or pure plastic friction partners where the self lubricating properties of plastics are either insufficient or must be improved.

Technical Data	9015	9024	9025	9027	9034
viscosity in cSt at 20°C	117	266	266	1040	58
viscosity in cSt at 50°C	27	45	45	130	16
pour point approx.	-40°C	-40°C	-40°C	-20°C	-50°C
temperature range from	-32°C	-18°C	-18°C	-7°C	-41°C
to	+70°C	+80°C	+90°C	+80°C	+60°C
acidity No. mg KOH/g	0.04	0.04	0.04	0,05	0.04
vapor pressure in Torr at 20°C	10 <sup>-8</sup>	10 <sup>-8</sup> -10 <sup>-9</sup>	10 <sup>-8</sup> -10 <sup>-9</sup>	10 <sup>-9</sup>	10 <sup>-7</sup> -10 <sup>-8</sup>
surface tension dyn/cm	33.8	34.8	35.0	35,5	32.9
adherence	very good	very good	very good	very good	good

Tests with the friction pendulum demonstrate very clearly the effect of these oils. With the friction pendulum we can measure the friction reducing effect of a lubricant with oscillating movements in connection with different friction partners. The freely swinging pendulum is set at 25° at the start and the amplitude of every third turning point is registered and noted in vertical columns.

The product No. 9024 being most widely used in fine mechanics, we show below the pendulum diagram of this oil. The other graph shows the damping curves of products No. 9015, 9024, 9025 and 9034.

Friction pendulum diagram  
of prod. No. 9024: steel/Delrin 500 NC 10

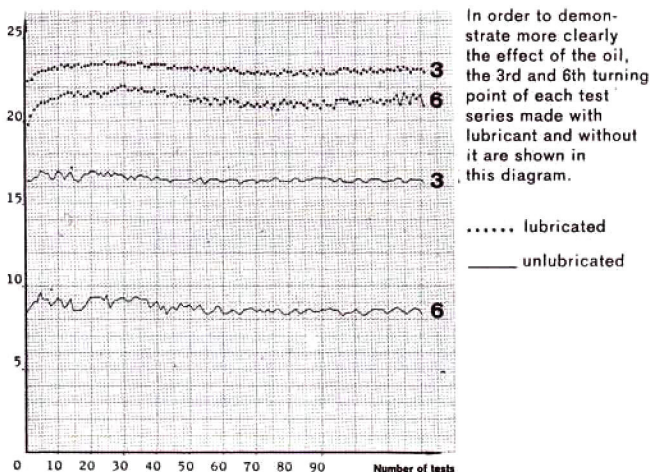

Damping curves — comparison of products

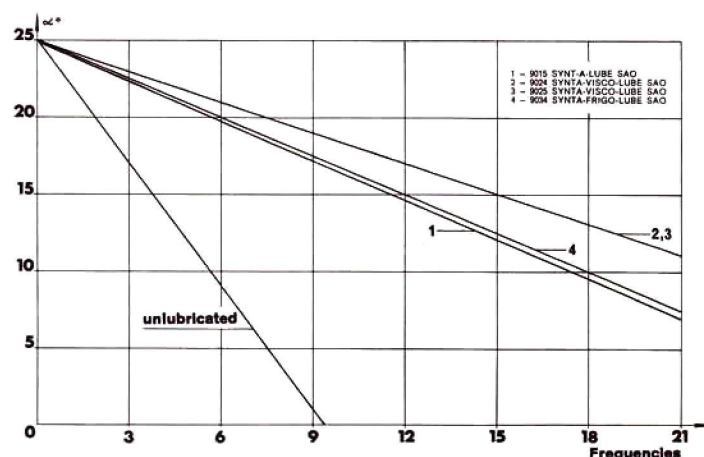

We shall be pleased to supply you with samples and detailed data.





## Epilame FIXODROP BS®

MOEBIUS FIXODROP BS is a new type of epilame on the basis of plastics, developed in our laboratories. It is economical and simple to use, yet it boasts important advantages compared with epilames on stearic acid basis:

- FRIGEN 113 TR-T which is used as a solvent, is neither toxic nor flammable
- It has an excellent compatibility with plastics.
- The obtained plastic film is considerably more resistant against washing with the usual detergents.

FIXODROP BS is available in two concentrations. The concentrate No. 8911 is mainly used by large consumers who dilute it themselves to obtain the normally used solution. Intermediate concentrations or even the concentrate are used for the treatment of rough surfaces of brass, aluminium or plastic. Product No. 8922 is the normally used solution for steel and ruby.

FIXODROP BS will solve practically all spreading problems. It can be used for the treatment of the escapement, jewel caps, plates, wheels, ball bearings. In case of plastic mechanisms, depending on the material and its surface condition, there may also be a high danger of spreading.

FIXODROP BS renders the best service in the treatment of the escapement. The photograph below demonstrates the barrier effect obtained with this product:

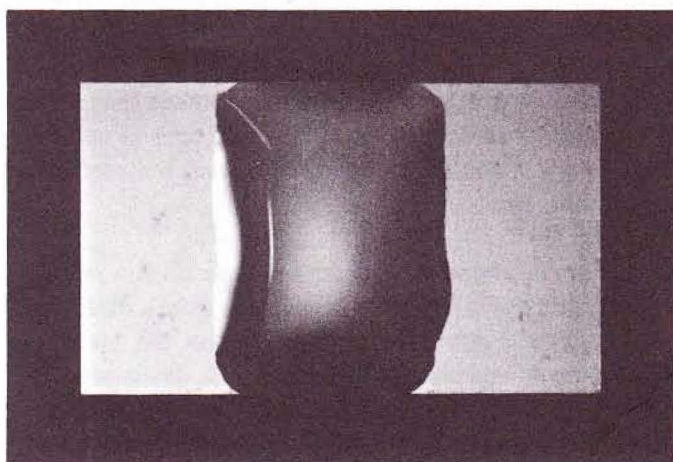

The  $>45^\circ$  edge angle of the oil drop remained absolutely unchanged during the test period of 6 months.

We shall be pleased to supply you with samples and detailed data.

## Cleaning, Lubrication, Surface Treatment

Three aspects with which manufacturers of watches as well as watch-makers are familiar as they are part of their daily work.

These three aspects with their connected spheres and effects influence the success of any work performed on the watch more strongly than most of those involved would assume.

Hereafter we shall deal with the prerequisites and inter-relations.

### *Cleaning*

Meticulous cleaning of the watches is one of the foremost prerequisites to obtain the best effect of the lubricant. This fact must be kept in mind each time when these two fields and their connected spheres are involved.

If they are disregarded, extensive and costly complaints will often result, and the origin of the problems is not always apparent.

Sometimes seeming economic advantages lead to neglect in this respect although in many cases no savings but, on the contrary, higher expenses will result.

Watches are soiled mainly by oils and grease in a state anywhere from liquid to completely gummed up, by solid particles from wear of friction points, peeled-off lacquer or glues, polishing agents, dust particles of different sizes, textil fibres, threads of plastic parts, by corrosion products such as rust, verdigris, etc. as well as by residues from galvanic baths.

While the manufacturer of watches rarely encounters several of these impurities at once, the repairing watch-maker often faces the problem of how to remove gummed-up oil from the bearings and stains unknown to him from the plates at the same time in one economical process.

When using the detergents and rinsing agents commonly offered on the market the watch-maker may expect that most of the impurities and stains will be dissolved and rinsed off, especially if implements are used which enhance the cleaning process mechanically (revolving, vibration, ultrasonic, vacuum). It is his responsibility, however, to control the degree of impurities of the baths and to see to it that the last rinsing bath – three should be used at all events – is renewed in due time. Unless this bath is really clean, it will leave invisible or even visible films on the surfaces of the cleaned parts. Such films may affect the oil applied later on in two respects, viz. increase its tendency to spread, and alter it chemically. Either of these events will have a detrimental influence on the most important function of the oil in the boundary lubrication: to form a firmly adhering film on the friction partners.



This clearly demonstrates the close interrelation between cleaning and lubrication. It is of utmost importance because its effects may influence the performance of the watch.

### *Lubrication and Surface Coating*

Watch-makers realized at an early stage the importance of lubricants in watches. They had to prepare the oil themselves as there was no general knowledge in this field nor the possibility of buying the oil ready made.

Those watch-makers were great masters in their domain, however hardly any one of them was able to devote his time to research in this field, and knowledge of chemistry in today's sense was non-existent.

Thus, lubricants were neglected for a long time in the watch industry.

Hermann Moebius was one of the first to realize the necessity of a change in this respect. In the middle of the 18th century he started testing oils systematically and manufactured them for sale.

Why do watches require special oils? In order to understand this necessity, we have to look at the main differences between watches and comparable micro-mechanic items on the one hand and large mechanisms on the other hand.

Due to their small sizes, micro-mechanisms require only minute quantities of lubricants. These lubricants, however, have to keep a mechanism working without any change, often for many years without being serviced and despite varying climatic conditions. It is therefore imperative that the lubricant remains on the friction points, and it must not spread or evaporate, and it also must not oxidize and gum up. Thus the lubricant has to meet with very high demands.

In large mechanisms the dimensions are completely different. The friction points are often running in oil baths which are renewed regularly, servicing is foreseen at regular intervals, the lubricant may spread and its volatility plays a subordinate role.

One of the most important differences lies in the speeds and pressures. While the friction partners in watches and comparable mechanisms are running at a very slow speed, very high pressures prevail in the bearings. This is the so-called boundary lubrication, i.e. the lubricant must form such a tight film on at least one friction partner that it can resist the extremely high pressures on the roughness peaks. These pressures can amount to 200 kg/mm<sup>2</sup>. This property is part of the lubricating qualities of an oil which are very difficult to define.

On the other hand we have the hydrodynamic lubrication. Medium to very high speeds are characteristic while only low pressures prevail in the bearings. While the mechanism is working, a constant film is formed between the friction partners which are thus separated. Therefore little wear results. In this type of lubrication the viscosity of the oil plays a more important role than in the boundary lubrication.

### *Which oils are to be used in watches?*

There are two main groups: the so-called classic oils and the synthetic oils. The classic oils are mixtures of animal or vegetable oils with mineral oils. Their assets are: good lubricating qualities, the capacity to form a high pressure resistant film and very limited spreading. These properties depend largely on the neat foot oil content in the mixture. Their major disadvantage is the poor oxidation stability. Depending on the environment, sometimes within a short period of time they start to thicken and eventually gum up. By adding certain stabilizers this development can be retarded but not avoided. Two processes are mainly responsible: reaction with the oxygen of the air and the catalytic action of the copper from the brass particles worn off the bearings.

Tests with the Baader apparatus showed that the oxidation process of classic oils takes place in a lineal manner, in a partly quite shallow curve, if anti-oxidizing stabilizers are present, while without the stabilizers the oxidation develops progressively. Stabilized classic oil is thus fairly resistant against oxidation for a certain time. The quantity of stabilizers which can be added to the oil is limited however, and decomposes while impeding oxidation. Therefore even the stabilized classic oils reach a point from which on oxidation will continue progressively.

In order to eliminate this undesirable property, research began about 50 years ago, aiming at stable lubricants. As a result we have at present two groups of lubricants, esters and ether-alcohols. From the chemical point of view, neither of them has anything in common with classic oils. It has been particularly the group of ether-alcohols which has made watch-makers conscious of the superiority of synthetic oils as compared with classic oils.

They possess a very high oxidation stability. Oxidation even under the toughest conditions can usually not be detected, as e.g. with SYNT-A-LUBE oils. On the other hand, their lubricating properties and pressure resistance are inferior. But with corresponding additives the oils have been improved sufficiently in these respects to stand up to the friction conditions in metal bearings. Due to their lower friction coefficient jewel bearings present less problems.

A further asset of the ether-alcohols is their good compatibility with almost all plastics. This aspect is of increasing importance as more and more plastics are used in the manufacture of micro and fine mechanical implements of all kinds and also in watches.

Recent tests have shown that with plastic/plastic and with plastic/metal friction partners the so-called self-lubricating properties of plastics are inadequate to guarantee sufficient friction impediment. In such cases lubrication with these oils has given satisfactory to good results. It is recommended, however, to use an epilame at least in certain places in order to avoid undesirable spreading of the oil.

An epilame should be used also where unfavourable geometric conditions make the retention of oil difficult, particularly on the impulse planes of the escapement wheel and the lever, and often shock-proof balance bearings. For the escapement a surface treatment is generally recommended. With such a treatment it can be avoided that through the sliding action the oil is pushed over the impulse plane



of the palletstones into the reaches of the lever from where it cannot flow back of its own accord. If this happens, and particularly when a film of impurities is left over from the cleaning process, the oil can spread to such an extent that it becomes invisible even with a magnifying glass. This occurrence frequently leads customers to complain about the oil having evaporated.

The evaporation of Synt-A-Lube for example is so low that it does not exceed one percent loss of weight with exposure to high temperatures (100°C) for several days and under normal conditions it cannot be measured at all. This means that complaints about seeming evaporation are actually prompted by the aforementioned spreading process. In such cases we always recommend the use of an epilame, e.g. Moebius Fixodrop BS, which presents no problems in its application and guarantees a practically unlimited oil retention.

When epilame treatment is performed, a very thin invisible coating is applied to the supporting material to change the surface tension of the support against the surface tension of the oil in such a way that the oil can no longer spread.

Previously, solid stearic acids were mainly used for this purpose, but they were not stable, i.e. they were not resistant against cleaning procedures. Today plastics are used, for example a perfluorinated plastic for Moebius Fixodrop BS. It is dissolved in a highly volatile solvent and its concentration can be adjusted to individual needs.

By simply dipping the cleaned parts into the solution an invisible, very thin and regular coating is obtained which provides for a good oil retention at critical points of watches and other micro and fine mechanical implements.