

*T*RAINING UNIT

NUMBER 11



FINISHING

BULOVA SCHOOL *of* WATCHMAKING

Copyrighted 1946—Bulova School of Watchmaking (Printed in U.S.A.)

277



FINISHING

Finishing is the term applied to the assembly of the complete balance and hairspring unit into the watch movement. It requires the combined skills and knowledge given in earlier training units. After a watch is properly finished, it is ready for the final timing and special adjusting.



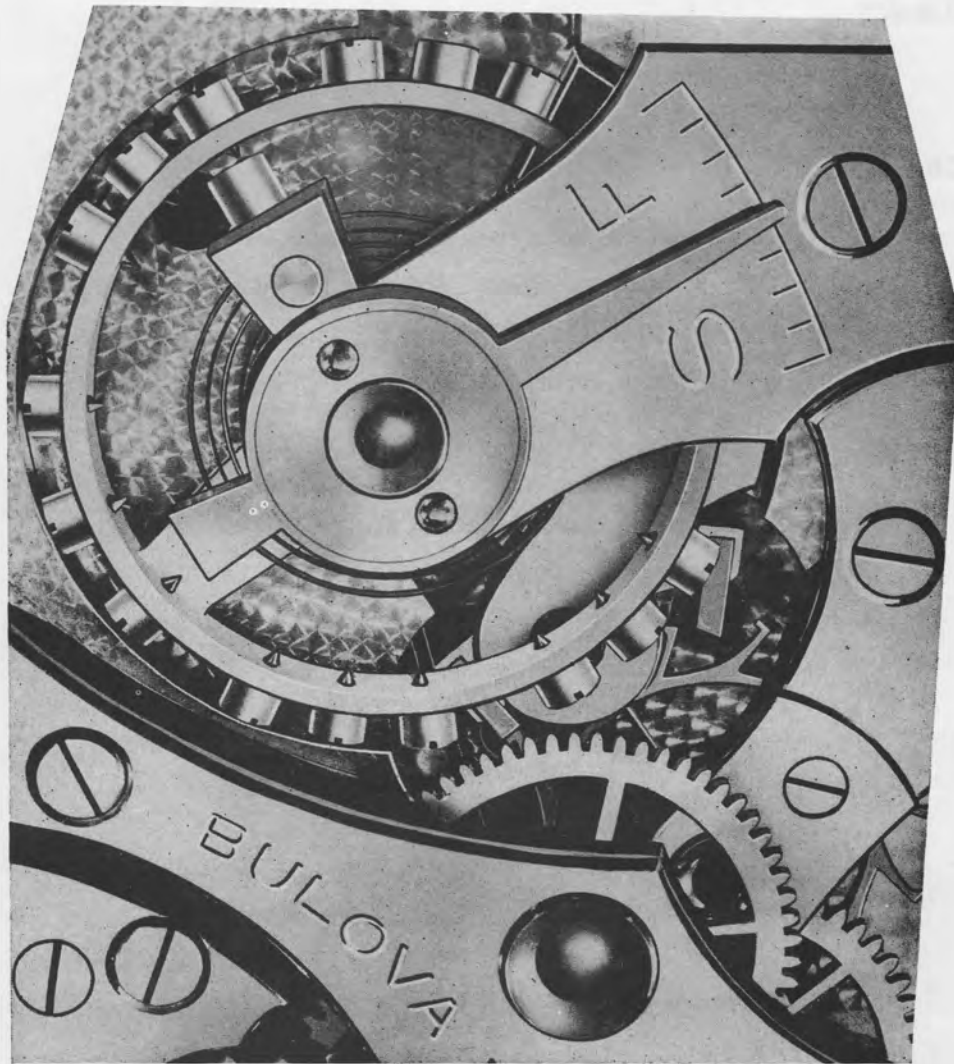

BULOVA SCHOOL *of* WATCHMAKING



BULOVA SCHOOL *of* WATCHMAKING

SUBJECT:

Finishing.

OBJECTIVE:

To present the basic requirements for the location of the overcoil and hairspring stud — to the end that hairsprings can be fitted easily into a watch movement.

TOOLS NEEDED:

1. Hairspring Leveler (Double End).
2. Regulator Pin Opener.
3. Hairspring Beat Tool and Hairspring Removing Tool.
4. Escapement Trying Tool.

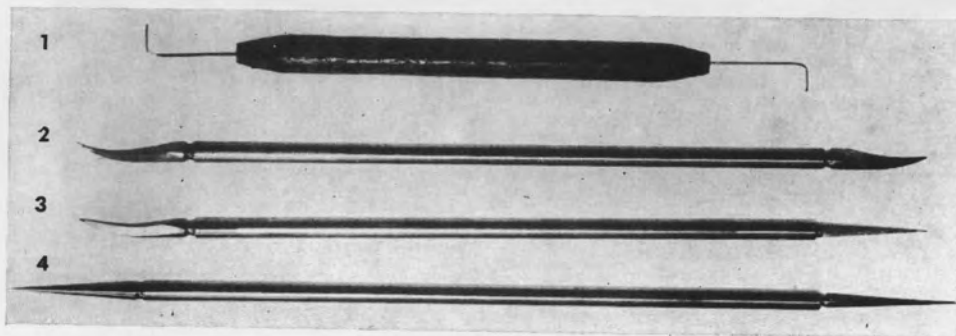

FINISHING

The art of finishing will be presented under the following main subdivisions:

Finishing

Common Terms Used in Finishing

Correct Conditions for a Properly Fitted Hairspring

Circling the Overcoil — Analysis of Overcoil Errors

Vibrating the Spring between Regulator Pins and
Circling the Overcoil

Centering the Spiral Portion of the Spring

Leveling the Spiral Portion of the Spring

Errors Which Will Result in Out of Level Conditions

Combining Out of Center and Out of Level Errors

How to Put a Watch in Beat



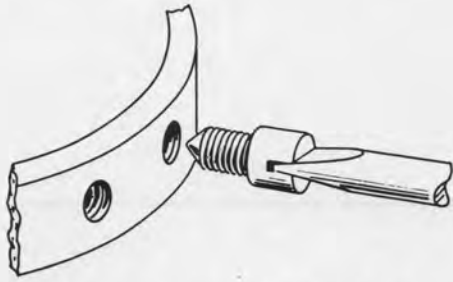

Balance screws must be tight in the balance wheel.

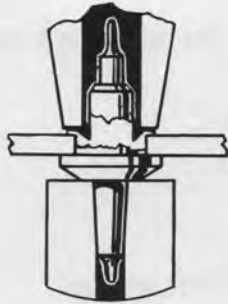

Balance staff must be staked tight on the balance wheel.

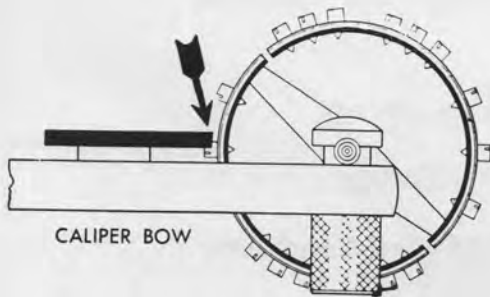

The balance wheel must be true in the round and flat.

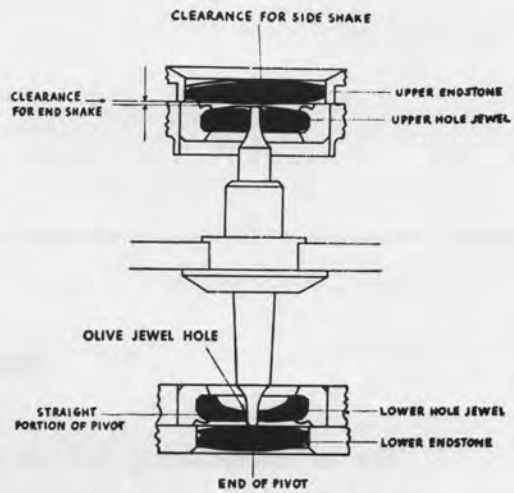
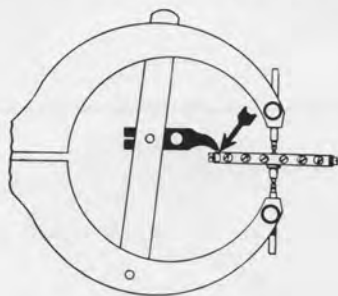

Pivots must be correctly shaped, properly burnished and accurately fitted to the jewels.

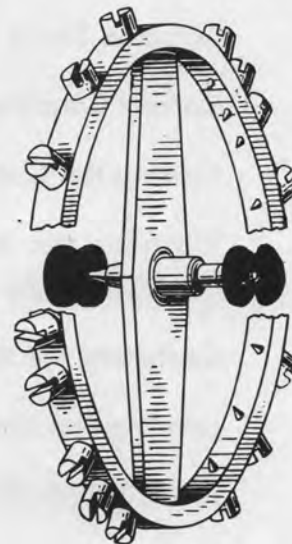

The balance wheel must be poised.

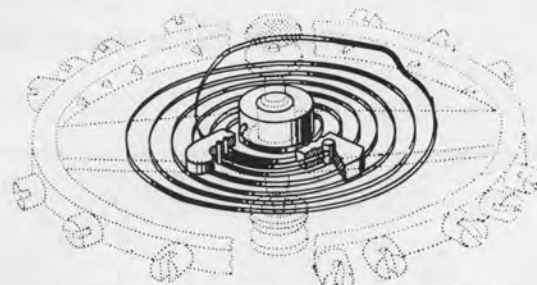

Collet must be staked firmly to the staff, the spring must be true in the round and flat.



FINISHING

Finishing should be approached with the assumption that the following conditions exist:

1. That the Balance wheel is tight on the balance staff. (See Training Unit No. 1).
2. That the Balance wheel is true in the round and flat. (See Training Unit No. 2).
3. That the Balance Pivots are correctly shaped, properly burnished and accurately fitted to the jewels. (See Training Unit No. 4.).
4. That the Balance Wheel is Poised. (See Training Unit No. 5.).
5. That the Collet is correctly staked and the spring is true in the round and flat. (See Training Unit No. 6).
6. That the Hairspring stud is tight and properly attached to the balance cock. (See training Unit No. 7).
7. That the Overcoil is the correct height and the correct shape. (See Training Unit No. 8).
8. That the Barrel Assembly and complete Train are free. (See Training Unit No. 9).
9. That the Escape Wheel and Pallet are properly matched. (See Training Unit No. 10).
10. Every moving part from the Barrel to the Balance Wheel should be free and properly fitted.

COMMON TERMS USED IN FINISHING

Hairspring OUT OF CENTER.

Hairspring OUT OF LEVEL.

Overcoil OUT OF LEVEL.

CIRCLE OVERCOIL.

VIBRATE OVERCOIL.

CLOSE REGULATOR PINS.

OPEN REGULATOR PINS.

MOTION. (Of the balance wheel)

PUT ESCAPEMENT IN BEAT.



CORRECT CONDITIONS FOR A PROPERLY FITTED HAIRSPRING

When the Overcoil is the correct height and shape and the stud is properly attached, the conditions shown in Fig. 1 will be established.

Here it is shown that the distance from the balance staff center to the stud and the points F-E-D-C are the same as the distance from the balance jewel hole to these same points. Therefore the stud will go into the stud hole, and the overcoil will fit between the regulator pins, permitting all of the coils of the spiral to be equally spaced and centered around the balance center.

Fig. 1 shows that the overcoil is the proper distance above the main body of the spiral. This insures that the spiral portion will be level. When the overcoil is too high, the spiral will be low. When the overcoil is too low, then the spiral will be too high.

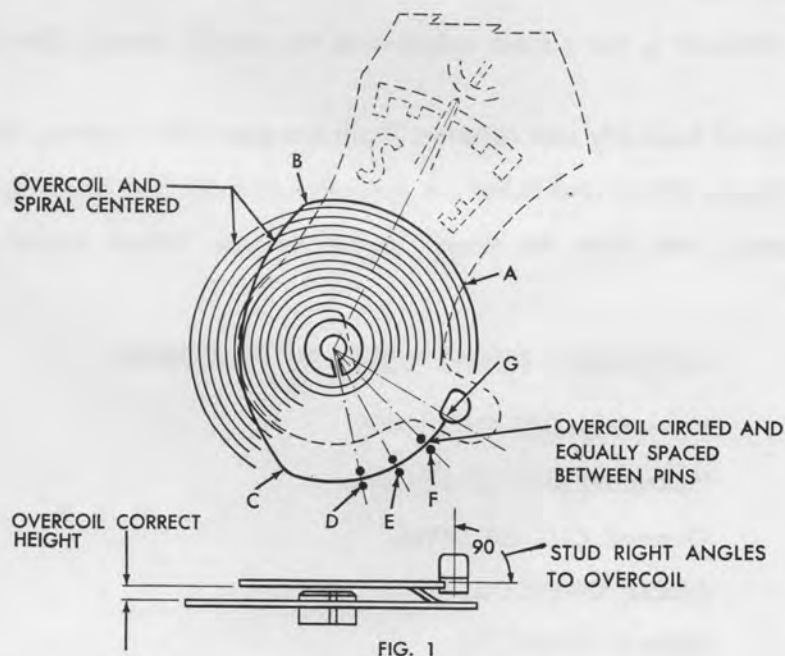

- FIG. 1
- E, REGULATOR PINS, WITH REGULATOR ON CENTER.
 - F, REGULATOR PINS, WITH REGULATOR TO SLOW.
 - D, REGULATOR PINS, WITH REGULATOR TO FAST.



CIRCLING THE OVERCOIL—ANALYSIS OF OVERCOIL ERRORS

Figure 2 shows the overcoil bent towards the balance staff. This is a direct result of a bend at point G. When the stud is placed in the balance cock, the overcoil should conform to the conditions shown in Fig. 1, but because of the bend at G, the overcoil will gradually curve inward towards the balance staff. The correction of this condition is known as "Circling the Overcoil."

Inspection of the watch which reveals this condition proceeds as follows:

1. Place regulator at the "slow" side of the balance cock, which moves the regulator pins to point F.
2. Move regulator from "slow" to "fast," causing regulator pins to move from F to D.

As the regulator pins move from F to D, the overcoil will move away from the balance staff. This shows that the overcoil is not circled. To correct this condition, move the regulator so the regulator pins will be as close to the stud as possible, then bend the overcoil in the direction of the arrow. Repeat the operation of moving the regulator from "slow" to "fast" and again observe the overcoil to determine if it remains motionless, or if it moves either towards the staff or away from the staff.

Figure 3 shows the overcoil bent away from the balance staff. From the explanation covering the condition in Fig. 2, it is possible to make the following statements in reference to circling the overcoil.

1. When the overcoil moves away from the balance staff, as the regulator pins are moved away from the stud, it will be necessary to bend the overcoil away from the staff to correct the error. (Fig. 2.)
2. When the overcoil moves towards the staff, as the regulator pins are moved away from the stud, it will be necessary to bend the overcoil toward the staff. (Fig. 3.)

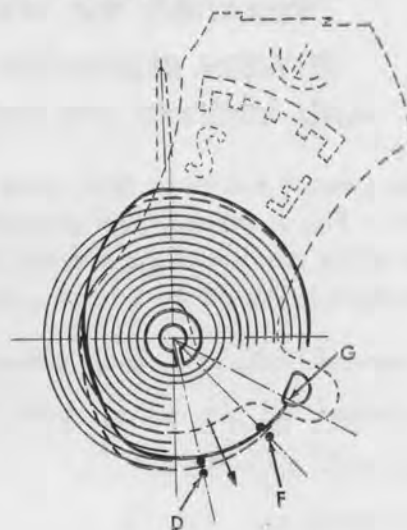

FIG. 2

CHART SHOWING OVERCOIL BENT TOWARD BALANCE STAFF. ARROW SHOWS DIRECTION OVERCOIL MUST BE BENT TO CORRECT.

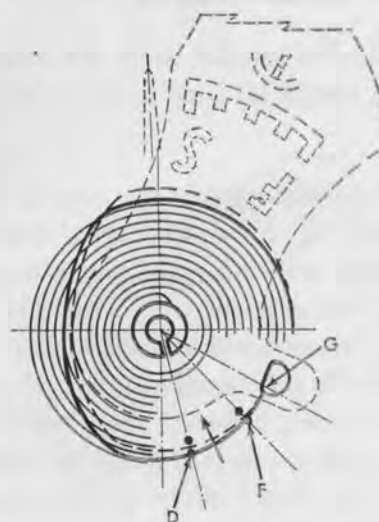

FIG. 3

CHART SHOWING OVERCOIL BENT AWAY FROM BALANCE STAFF. ARROW SHOWS DIRECTION OVERCOIL MUST BE BENT TO CORRECT.



VIBRATING THE SPRING BETWEEN REGULATOR PINS AND CIRCLING THE OVERCOIL

After the overcoil has been bent away from the balance staff as explained in Fig. 2, the regulator pins should be moved to position *F*. Look at the position of the overcoil between the pins; it will probably conform to one of the following conditions:

1. Equally spaced and pins properly closed. (Fig. 4.)
2. Equally spaced and pins slightly open. (Fig. 5.)
3. Touching inside pin. (Fig. 6.)
4. Touching outside pin. (Fig. 7.)
5. Pins too far apart and overcoil touching bottom of pins only. (Fig. 8.)
6. Pins too far apart but outside pin bent so end of pin will be parallel with pin. (Fig. 9.)

If the overcoil touches either the inside or outside pin (Fig. 6-7), the overcoil should be bent so as to bring it more central between the pins.

Let us now assume that the overcoil is directly in the center of the two pins (Fig. 5), make sure of this condition by stopping the balance wheel with the jewel pin in the fork slot and observe the location of the overcoil with a double eyeglass. Now move the regulator so the pins will be located at *D*, look at the overcoil again and decide if it still remains in the same central position between the pins. If it does, it can be seen that when the regulator pins are closed up to the spring that it will be possible to move the regulator from "slow" to "fast," carrying the pins from *F* to *D* without disturbing the location of the overcoil.

This method of locating the overcoil in the center of the regulator pins for all points from *F* to *D* accomplishes two operations at once; that is:

1. Vibrates the spring between the regulator pins.
2. Circles the overcoil.

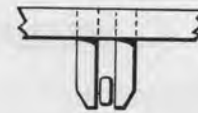

FIG. 4

- NO. 1. EQUALLY SPACED AND PINS PROPERLY CLOSED. FREEDOM FOR OVERCOIL SHOULD BE .0003" OR .0076 MM.

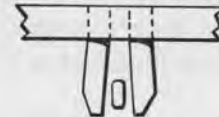

FIG. 5

- NO. 2. EQUALLY SPACED AND PINS SLIGHTLY OPEN.

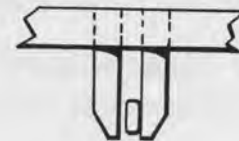

FIG. 6

- NO. 3. SPRING TOUCHING INSIDE PIN.

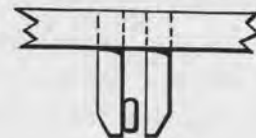

FIG. 7

- NO. 4. SPRING TOUCHING OUTSIDE PIN.

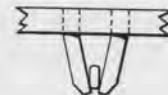

FIG. 8

- NO. 5. PINS LOCATED TOO FAR APART IN REGULATOR. PINS AT ANGLE, SPRING TOUCHES PINS AT BOTTOM. THIS WILL CAUSE ERROR IN RATE BETWEEN THE DIAL UP AND DIAL DOWN POSITIONS.

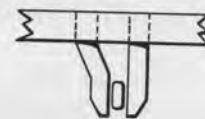

FIG. 9

- NO. 6. PINS LOCATED TOO FAR APART IN REGULATOR, BUT OUTSIDE PIN IS BENT SO THAT END OF PIN WILL BE PARALLEL WITH INSIDE PIN.



CENTERING THE SPIRAL PORTION OF THE SPRING

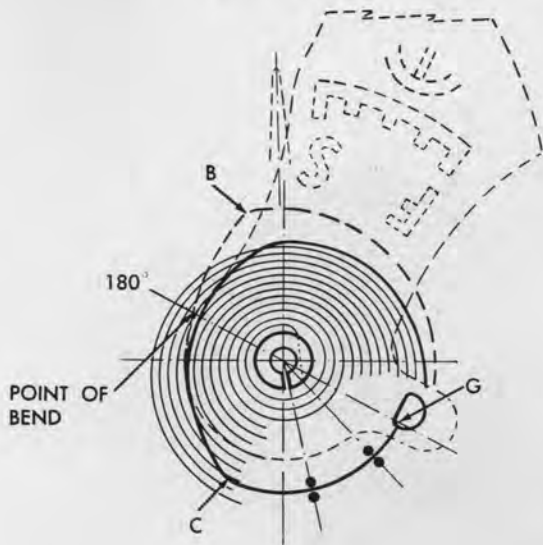

FIG. 10

CHART SHOWING OVERCOIL BENT 180° FROM STUD, BENDING POINT B TOWARD STAFF.

Figure 10 shows the overcoil bent 180° from the stud, bending point B towards the balance staff. The overcoil C-G under this condition will no longer lie over the top of the second coil as shown in Fig. 1, but depending upon the amount of bending at the point 180° from the stud, the overcoil may lie over the third or fourth coil. All of the coils underneath the regulator pins will be wider apart than the coils underneath the balance cock and the spring will be "out of center."

The remedy for this error is to grasp the spring with a pair of good tweezers 180° from the stud and bend the overcoil in such a manner as to carry point B away from the balance staff.

Figure 11 is just the reverse from Fig. 10 and all of the errors and the remedy stated above will be reversed.

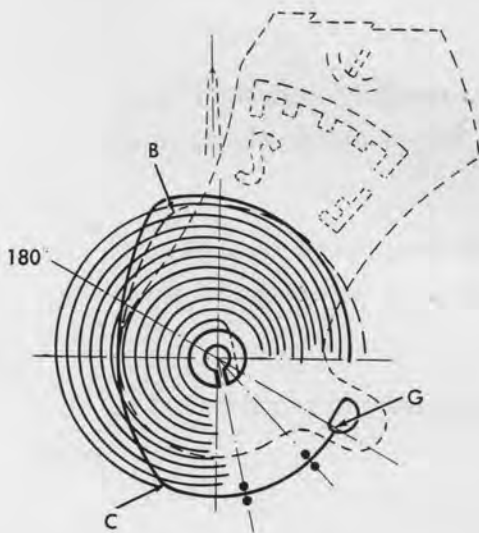

FIG. 11

CHART SHOWING OVERCOIL BENT 180° FROM STUD, BENDING POINT B AWAY FROM STAFF.

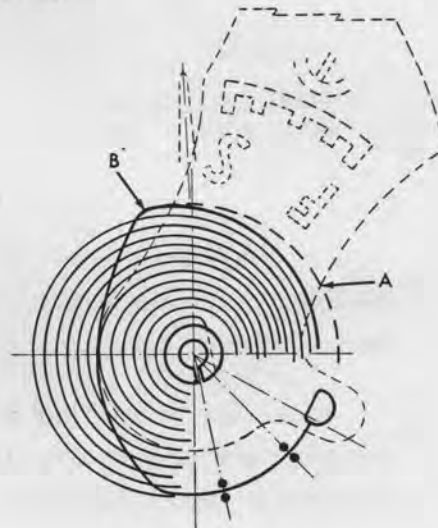

FIG. 12

CHART SHOWING OVERCOIL BENT AT POINT B, TAKING POINT A TOWARD STAFF.

Figure 12 shows the overcoil bent at point B carrying point A towards the staff. This will cause the spring to be "out of center." The remedy is to bend the spring at point B so as to carry point A away from the staff.



CENTERING THE SPIRAL PORTION OF THE SPRING

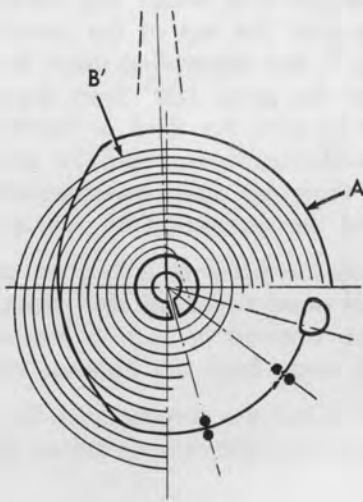

Fig. 13

CHART SHOWING OVERCOIL BENT AT POINT A, TAKING POINT B' TOWARD STAFF.

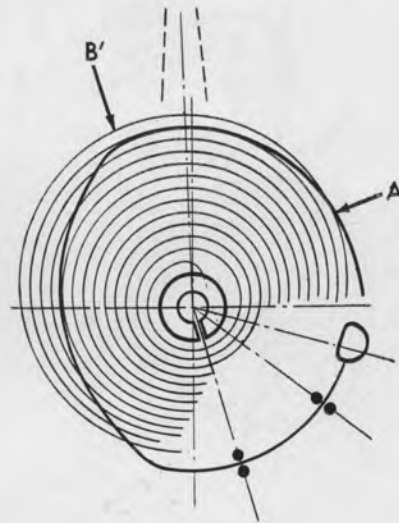

Fig. 14

CHART SHOWING OVERCOIL BENT AT POINT A, TAKING POINT B' AWAY FROM STAFF.

If all the figures from 1 to 14 are studied carefully, keeping in mind the conditions shown in Fig. 1, one begins to form a mental picture of all the fundamental operations of finishing.

It also can be seen that in each case, the error caused by a bend at any point always throws the spring out of center in the same manner as described in Figs. 6-7-8-Training Unit No. 6.

This provides a means of readily locating the point to grasp the spring for centering.



LEVELING THE SPIRAL PORTION OF THE SPRING

In order that the spiral portion of the spring be level when placed in a watch, the overcoil must be the correct height above the spiral.

This height must be equal at all points of the overcoil. The stud must be attached perpendicular to the plane of the overcoil, observed from any position. (Fig. 15.)

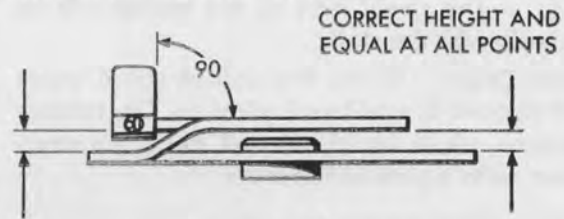

FIG. 15

ERRORS WHICH WILL RESULT IN OUT OF LEVEL CONDITIONS

OVERCOIL TOO HIGH. (Fig. 16.)

RESULT —Spiral part of spring will be too low when placed in the watch.

CORRECTION —Remove the balance and spring, then lower the overcoil to its correct height.

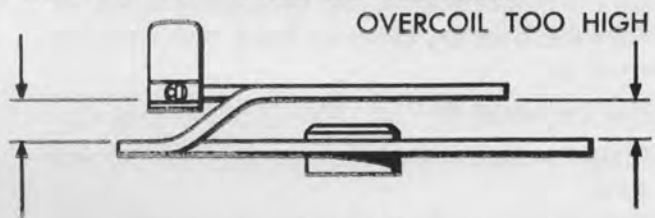

FIG. 16

OVERCOIL TOO LOW. (Fig. 17.)

RESULT —Spiral part of spring will be too high when placed in the watch.

CORRECTION —Remove the balance and spring, then raise the overcoil to its correct height.



FIG. 17

STUD TOO HIGH. (Fig. 18.)

RESULT —Spiral part of the spring will be too low under the stud.

CORRECTION —Grasp the overcoil opposite the stud, at point A and bend the body of the spiral upwards, under the stud.

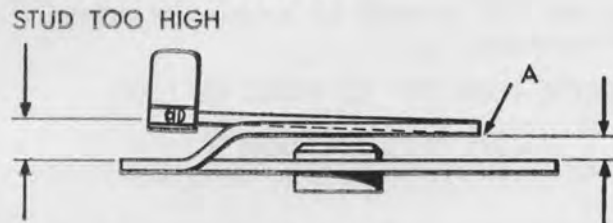

FIG. 18

STUD TOO LOW. (Fig. 19.)

RESULT —Spiral part of spring will be high under the stud.

CORRECTION —Grasp the overcoil opposite the stud, at point A and bend the body of the spiral downwards, under the stud.

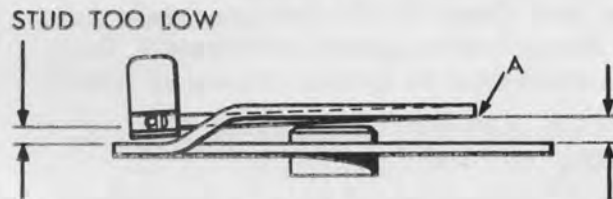

FIG. 19



LEVELING THE SPIRAL PORTION OF THE SPRING

OVERCOIL HIGH OPPOSITE THE STUD. (Fig. 20.)

RESULT — The spiral part of the spring will be too low opposite the stud.

CORRECTION — Grasp first coil of spiral under the stud at point B, and bend spiral up. Or, remove the balance, place on block, and bend the overcoil down, with a pair of tweezers.



FIG. 20

OVERCOIL LOW OPPOSITE STUD. (Fig. 21.)

RESULT — The spiral part of the spring will be high opposite the stud.

CORRECTION — Grasp the first coil of spiral, under the stud at point B, and bend spiral down. Or remove the balance, place on block and bend the overcoil up.

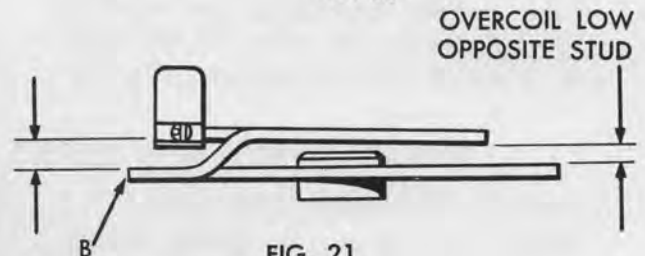

FIG. 21

OVERCOIL HIGH 90° TO LEFT OF STUD. (Fig. 22.)

RESULT — Spiral part will be low 90° to left of stud.

CORRECTION — Note that the bend will probably be at point C under the balance cock, which makes it difficult to grasp and bend. Safest method is to remove the balance, then correct overcoil by grasping spring at point C and bend point D down.

OVERCOIL HIGH 90° TO LEFT OF STUD

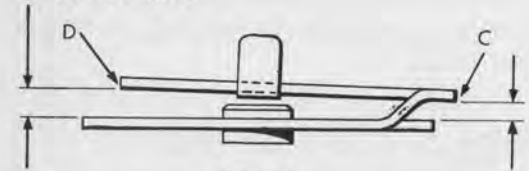

FIG. 22

OVERCOIL LOW 90° TO LEFT OF STUD. (Fig. 23.)

RESULT — Spiral part will be high 90° to left of stud.

CORRECTION — Remove the balance, place on block and raise overcoil, by grasping at point C and bend Point D up.

OVERCOIL LOW 90° TO LEFT OF STUD

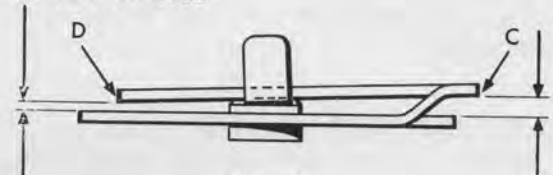

FIG. 23

OVERCOIL HIGH 90° TO RIGHT OF STUD. (Fig. 24.)

RESULT — Spiral will be low 90° to right of the stud.

CORRECTION — In this condition the spiral can be grasped at point E, and the outside coil of the spring bent down. **NOTE**—This error could have been the result of too great a rise at point F. Therefore overcoil could be lowered at bend up point F.

OVERCOIL HIGH 90° TO RIGHT OF STUD



FIG. 24

OVERCOIL LOW 90° TO RIGHT OF STUD. (Fig. 25.)

RESULT — Spiral part of spring will be high 90° to the right of the stud.

CORRECTION — Grasp the spring at point E and bend the outside coil of the spiral upwards. Or raise overcoil at bend up point F.

OVERCOIL LOW 90° TO RIGHT OF STUD

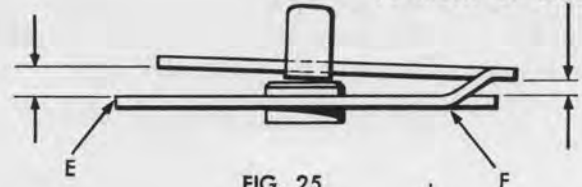

FIG. 25



LEVELING THE SPIRAL PORTION OF THE SPRING

STUDS NOT PERPENDICULAR TO THE PLANE OF THE OVERCOIL

ERROR — Stud bent away from the balance staff. (Fig. 26.)

RESULT— Overcoil and spiral low opposite the stud.

CORRECTION— Grasp spring at stud and bend overcoil up.

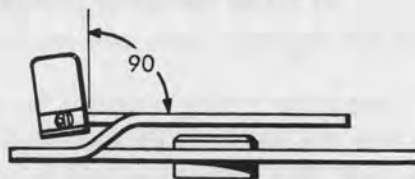

FIG. 26

STUD BENT AWAY FROM BALANCE STAFF.

ERROR — Stud bent toward the balance staff. (Fig. 27.)

RESULT— Overcoil and spiral high opposite the stud.

CORRECTION— Grasp spring at stud and bend overcoil down.

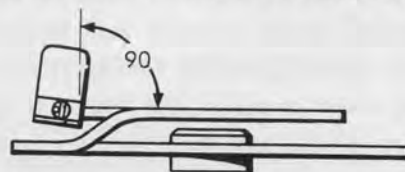

FIG. 27

STUD BENT TOWARD BALANCE STAFF.

ERROR — Stud bent to the right of the balance staff. (Fig. 28.)

RESULT— Overcoil and spring low to the left of staff.

CORRECTION— Place tweezers under overcoil at stud and bend up.

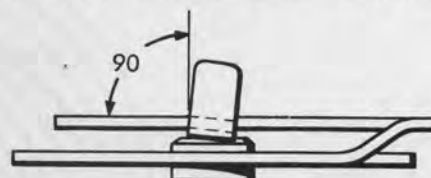

FIG. 28

STUD BENT TO RIGHT OF BALANCE STAFF.

ERROR — Stud bent to the left of the balance staff. (Fig. 29.)

RESULT — Overcoil and spring high to the left of staff.

CORRECTION— Place tweezers on top of the overcoil, at stud, and bend overcoil down.

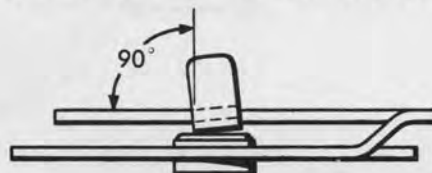

FIG. 29

STUD BENT TO LEFT OF BALANCE STAFF.

It must be obvious from the foregoing analysis of OUT OF LEVEL conditions, that finishing becomes necessary because of the slight errors in forming the overcoil, and attaching the stud. The actual bending operations necessary to correct these conditions can usually be determined from the error itself



COMBINING OUT OF CENTER AND OUT OF LEVEL ERRORS

Fig. 30 shows the spiral part of the spring out of center with the coils too wide apart directly under the regulator pins, and too close to the stud in the flat position.

Grasp the spring opposite the stud at point A, as explained in the manipulative operations, and turn the tweezers counter-clockwise, at the same time tipping the tweezers towards the balance staff. This will center and level the spring with one bend.

Double bends of this type can be used for practically all conditions where a double error exists.

It is not possible to illustrate correctly all of the various combinations of errors that do exist. However, it can be seen that finishing requires the ability to perform all of the bends explained under MANIPULATIVE OPERATIONS and to combine this ability with a knowledge of the errors which exist in either the OUT OF CENTER or OUT OF LEVEL condition of the overcoil or spiral portion of the spring.

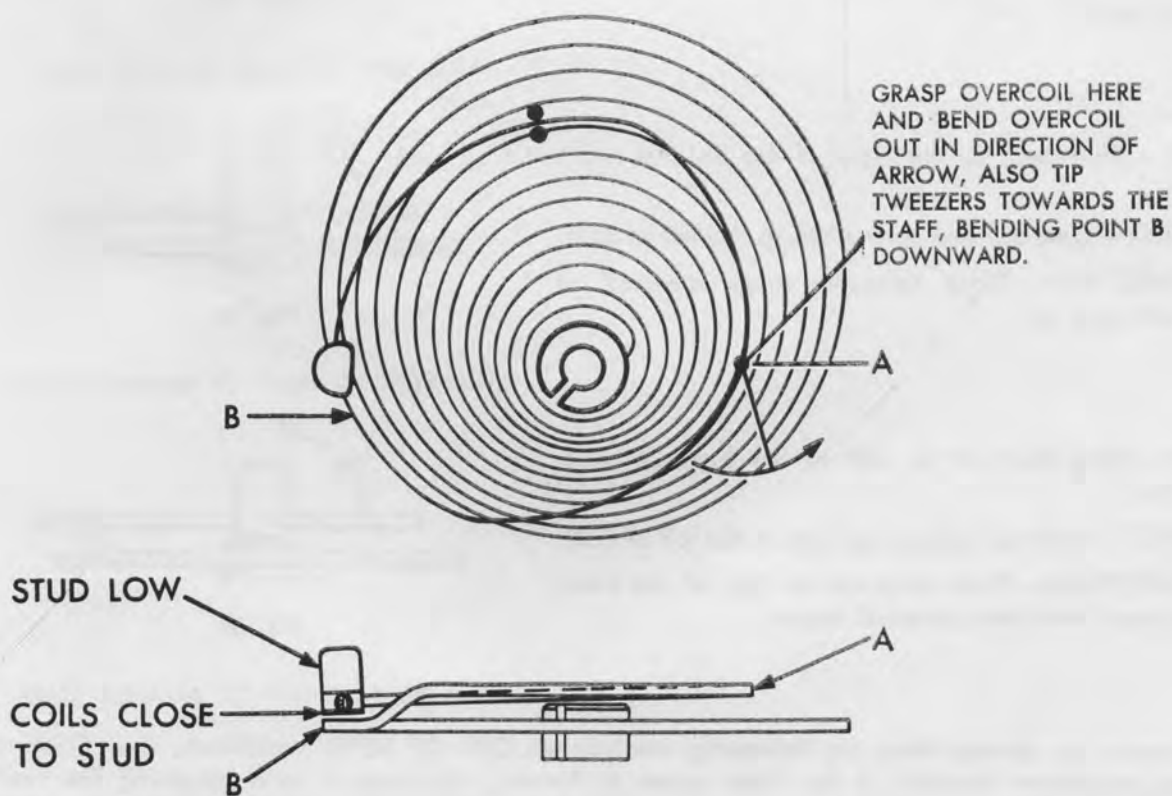

FIG. 30



HOW TO PUT A WATCH IN BEAT

After the overcoil has been leveled, circled and vibrated and the spiral portion of the spring leveled and centered, the balance and hairspring must be put IN BEAT.

The function of the hairspring is to return the jewel pin to the line of centers of the escape, pallet and balance in a pre-determined time. From this can be developed the statement that a watch is considered to be in beat if the jewel pin lies on this line of centers when the hairspring is unstressed. See Fig. 31. Or it can be stated that a watch is in beat when the hairspring is unstressed and the jewel pin is midway between the two banking pins, on condition that the banking pins are properly located.

A watch is considered to be out of beat when the hairspring is attached to the balance staff in such a position that when the hairspring is unstressed, it will hold the jewel pin some number of degrees away from the line of centers.

A simple way to determine whether or not a watch is in beat is to hold the watch in the dial down position. Then by use of a beat tool proceed to stop the balance, that is, try to get an escape wheel tooth to stay locked on either the R or the L Stone of the pallet. This operation must be done gently and care must be taken not to damage the balance pivots or scratch the balance wheel. It can best be done by allowing a balance screw to hit against the beat tool. If it is impossible to stop the motion of the balance, it may be considered that the watch is in beat.

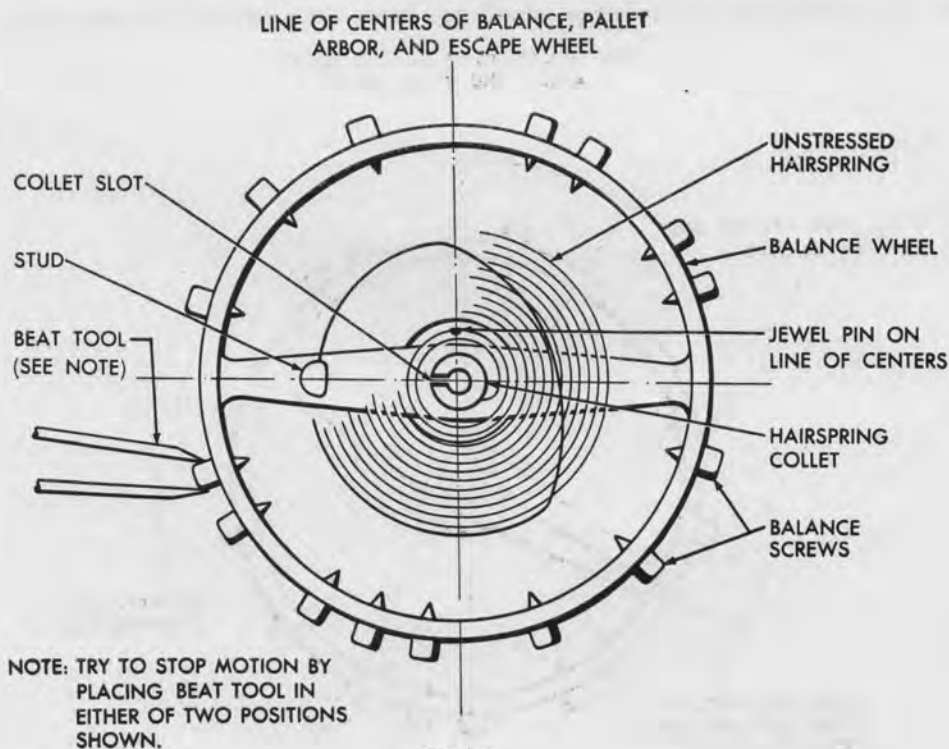

FIG. 31

WATCH IN DD POSITION.



HOW TO PUT A WATCH IN BEAT — (Continued)

If it is found that the balance can be stopped, the next step is to test for the direction of the starting push. This is done with the beat tool which is carefully brought into contact with a balance screw. When the slightest touch or push releases the escapement and starts the balance in motion, it can be considered to be the correct direction of the starting push. Had the beat tool been put on the opposite side of the same screw and pushed, the push would have been applied in the wrong direction and the escapement would not have been released. It is the starting push that causes the jewel pin to hit against the fork slot of the pallet which in turn unlocks the tooth of the escape wheel. We are thus able to determine on which side of the line of centers the jewel pin was when the motion of the balance wheel was arrested. This information tells us that when the hairspring is unstressed, the jewel pin will lie on that side.

To correct this error and thus bring the watch in beat, we may use either one of the following two methods:

1. Hold the collet by inserting the beat tool into the collet slot. Then proceed to turn the balance wheel in the same direction as the starting push.
2. Hold the balance wheel and with the beat tool move the collet in the opposite direction of the starting push.

Only experience will teach us how much to move the collet relative to the balance staff in order to put the escapement in beat.

Fig. 32 is a case where the balance wheel has been stopped with the beat tool, the pallet re-

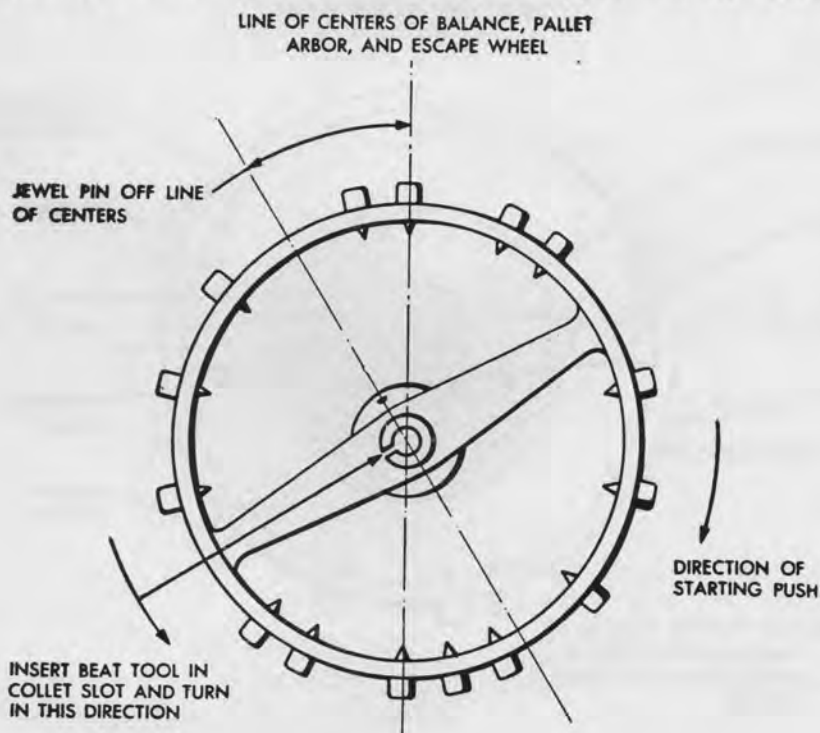

FIG. 32



HOW TO PUT A WATCH IN BEAT—(Continued)

maining locked on the let-off or L stone. The jewel pin, as indicated, is positioned to the left of the line of centers. (The balance wheel is nearest the observer while the escape wheel is the farthest away.) From what has been explained before, it is understood that the watch is out of beat and that the jewel pin would lie to the left of the line of centers when the hairspring was unstressed. Under this particular circumstance, it would be found that by pushing the balance with the beat tool in the direction of the arrow, the balance would continue to turn in that direction until it reached the end of a vibration. This proves that the jewel pin was to the left of the line of centers.

The remedy for this error is to employ any one of the two aforementioned methods. Either method achieves the same objective, namely, that of shifting the hairspring collet so that the jewel pin will be on the line of centers.

Fig. 33 shows a case where the balance wheel has been stopped, the pallet remaining locked on the receiving or R stone. The jewel pin, as indicated, is positioned to the right of the line of centers (balance nearest the observer-escape wheel farthest away). We have an indication here that the watch is out of beat and that the jewel pin would be to the right of the line of centers when the hairspring is unstressed.

By use of either of the two above mentioned methods, the collet can be shifted relative to

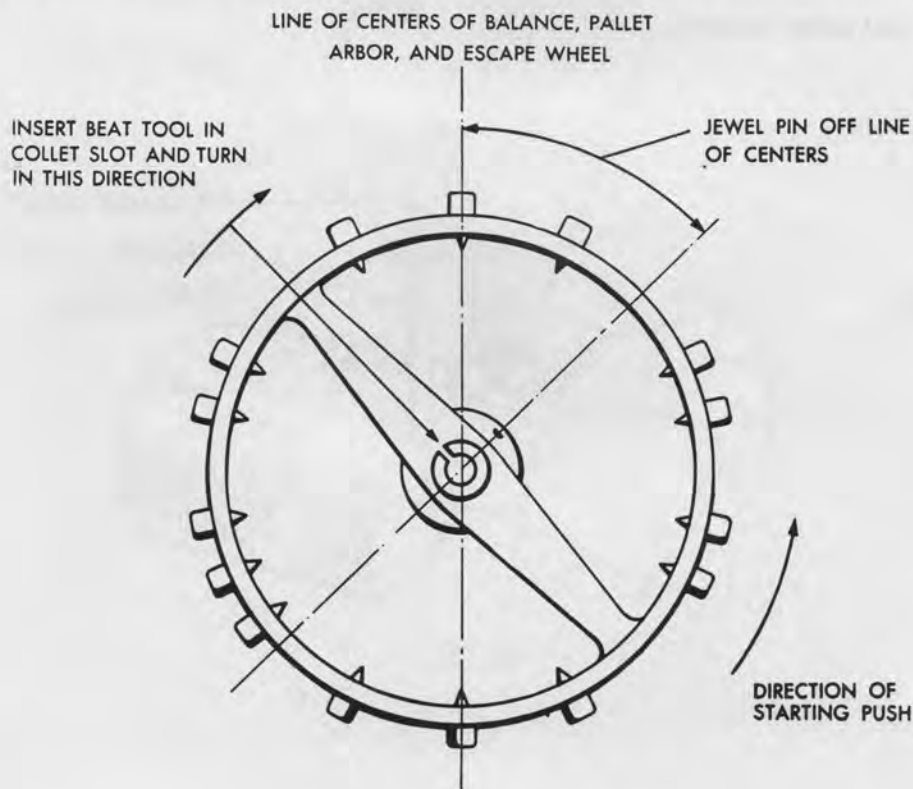

FIG. 33



Training Unit Number 11

the balance staff and thus the jewel pin will be brought to the line of centers, thereby putting the watch in beat.

When it is impossible to reach the collet while the balance wheel is in the watch, then it is advisable to remove the balance cock before attempting to shift the hairspring collet. This method will avoid the possibility of damage to the hairspring or pivots.

As shown in Fig. 34, the balance cock is placed on a tapered piece of pegwood or brass, resting in a hole of the bench anvil. The suspended balance wheel is then held in the fingers of the left hand as the collet is shifted to its proper position by carefully locating the beat tool held in the right hand through the coils of the hairspring into the collet slot.

The direction in which the collet is moved is exactly the same as explained when putting the watch in beat without removing the balance cock; namely, turn the collet clockwise when a counter-clockwise movement of the balance wheel is desired, and vice versa.

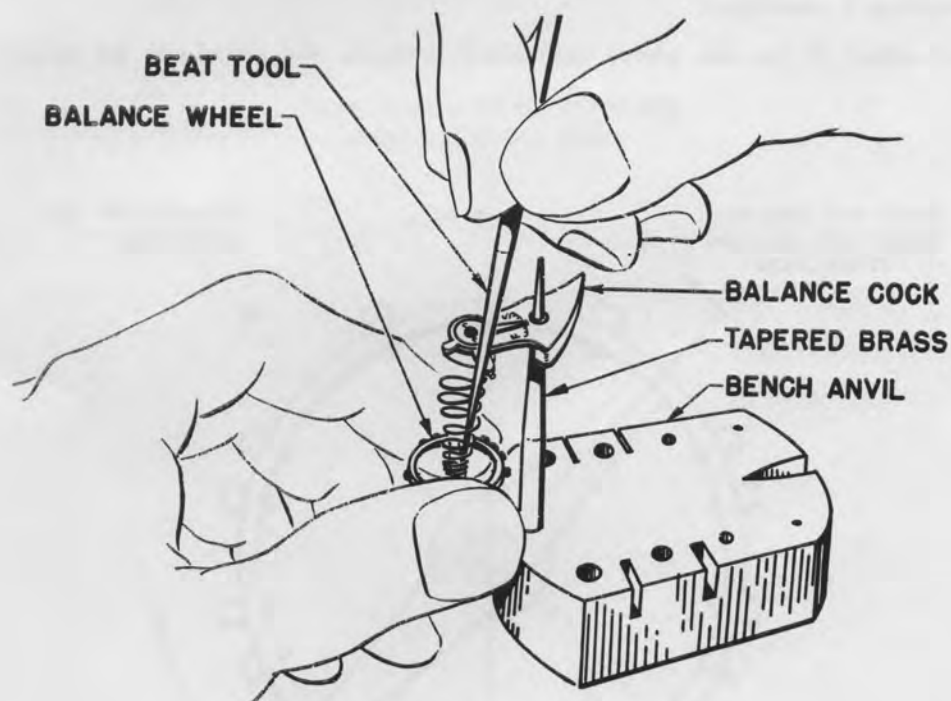

FIG. 34

