



Maître Horloger - Les Genevez  
depuis 1884

**EDOXIONARY**  
FOR WATCH PROFESSIONALS  
2017 - 2018

REFERENCE	COLLECTION	NAME	P.	
01118 3	NO	Chronorally 1	Chronograph Automatic	54
01118 37NR	NRO	Chronorally 1	Chronograph Automatic	54
01120 3	AIN	Les Bémonts	Chronograph Automatic	109
01120 3	BUIN	Les Bémonts	Chronograph Automatic	109
01120 3	GIN	Les Bémonts	Chronograph Automatic	109
01120 37R	AIR	Les Bémonts	Chronograph Automatic	108
01120 37R	GIR	Les Bémonts	Chronograph Automatic	108
01120 37RM	AIR	Les Bémonts	Chronograph Automatic	108
01120 37RM	GIR	Les Bémonts	Chronograph Automatic	108
01120 3M	AIN	Les Bémonts	Chronograph Automatic	109
01120 3M	BUIN	Les Bémonts	Chronograph Automatic	109
01120 3M	GIN	Les Bémonts	Chronograph Automatic	109
01121 357RN	GIR	Grand Ocean	Chronograph Automatic	12
01122 3	BUIN	CO-1	Chronograph Automatic	26
01122 3	NIN	CO-1	Chronograph Automatic	26
01122 37R	NIR	CO-1	Chronograph Automatic	27
01122 3BN	BINN	CO-1	Chronograph Automatic	27
01122 3BNM	BINN	CO-1	Chronograph Automatic	27
01122 3M	BUIN	CO-1	Chronograph Automatic	26
01122 3M	NIN	CO-1	Chronograph Automatic	26
01122 3N	BUINO	CO-1	Chronograph Automatic	26
01122 3NM	BUINO	CO-1	Chronograph Automatic	26
01123 357RCA	NBUR	Grand Ocean	Chronograph Automatic	12
01123 3BUCA	NBUN	Grand Ocean	Chronograph Automatic	12
01123 3ORCA	ABUN	Grand Ocean	Chronograph Automatic	12
01602 3	AIN	Les Bémonts	Perpetual Calendar	119
01602 3	NIN	Les Bémonts	Perpetual Calendar	119
01602 37J	AID	Les Bémonts	Perpetual Calendar	119
01602 37J	BRID	Les Bémonts	Perpetual Calendar	119
01602 37R	AIR	Les Bémonts	Perpetual Calendar	119
01602 37R	GIR	Les Bémonts	Perpetual Calendar	119
01651 3	AIN	Les Bémonts	Chronograph Moon Phase	121
01651 3	AR	Les Bémonts	Chronograph Moon Phase	121
01651 3	NIN	Les Bémonts	Chronograph Moon Phase	121
01651 37J	AID	Les Bémonts	Chronograph Moon Phase	120
01651 37J	AR	Les Bémonts	Chronograph Moon Phase	120
01651 37R	AIR	Les Bémonts	Chronograph Moon Phase	120
01651 37R	AR	Les Bémonts	Chronograph Moon Phase	120
01651 37R	BUIR	Les Bémonts	Chronograph Moon Phase	120
10108 3BU	AIN	Delfin The Original	Chronograph	75

REFERENCE	COLLECTION	NAME	P.	
10109 357GNCA	NINB	Delfin The Original	Chronograph	75
10109 357JVM	VID	Delfin The Original	Chronograph	75
10109 357NCA	NIN	Delfin The Original	Chronograph	75
10109 357RBUM	NIR	Delfin The Original	Chronograph	74
10109 357RNCA	NIRG	Delfin The Original	Chronograph	74
10109 3CA	AIN	Delfin The Original	Chronograph	74
10109 3CA	BUIN	Delfin The Original	Chronograph	74
10109 3M	AIN	Delfin The Original	Chronograph	74
10109 3M	BUIN	Delfin The Original	Chronograph	74
10109 3M	NIN	Delfin The Original	Chronograph	75
10110 357JCA	AID	Delfin The Original	Chronograph	76
10110 357JM	AID	Delfin The Original	Chronograph	76
10110 357RCA	AIR	Delfin The Original	Chronograph	76
10110 357RNCA	NIR	Delfin The Original	Chronograph	76
10110 3CA	AIN	Delfin The Original	Chronograph	77
10110 3CA	BUIN	Delfin The Original	Chronograph	77
10110 3CA	NIN	Delfin The Original	Chronograph	77
10110 3M	AIN	Delfin The Original	Chronograph	77
10110 3M	BUIN	Delfin The Original	Chronograph	77
10110 3M	NIN	Delfin The Original	Chronograph	77
10220 357RC	AIR	LaPassion	Chronograph	92
10220 357RC	AR	LaPassion	Chronograph	92
10220 357RC	NIR	LaPassion	Chronograph	92
10220 357RM	AIR	LaPassion	Chronograph	92
10220 357RM	AR	LaPassion	Chronograph	92
10220 357RM	NIR	LaPassion	Chronograph	92
10220 37RC	AIR	LaPassion	Chronograph	90
10220 37RC	AR	LaPassion	Chronograph	90
10220 37RC	BRIR	LaPassion	Chronograph	90
10220 37RC	NIR	LaPassion	Chronograph	91
10220 37RC	ROUIR	LaPassion	Chronograph	91
10220 37RM	AIR	LaPassion	Chronograph	90
10220 37RM	AR	LaPassion	Chronograph	90
10220 37RM	BRIR	LaPassion	Chronograph	90
10220 37RM	NIR	LaPassion	Chronograph	91
10220 3C	AIN	LaPassion	Chronograph	94
10220 3C	AR	LaPassion	Chronograph	94
10220 3C	BUIN	LaPassion	Chronograph	94
10220 3C	NIN	LaPassion	Chronograph	95
10220 3C	ROIN	LaPassion	Chronograph	95
10220 3M	AIN	LaPassion	Chronograph	94
10220 3M	AR	LaPassion	Chronograph	94
10220 3M	BUIN	LaPassion	Chronograph	94
10220 3M	NIN	LaPassion	Chronograph	95
10220 3M	ROIN	LaPassion	Chronograph	95
10221 3	NIN	CO-1	Chronograph	31
10221 357R	BINR	CO-1	Chronograph	31
10221 357RM	BINR	CO-1	Chronograph	31
10221 37N	NINJ	CO-1	Chronograph	33
10221 37R	NIR	CO-1	Chronograph	33
10221 37RBU7	BIR7	CO-1	Chronograph	29
10221 37RBU7	BUIR7	CO-1	Chronograph	29
10221 3BU7	BUIN7	CO-1	Chronograph	29
10221 3M	NIN	CO-1	Chronograph	31
10221 3N	BUINO	CO-1	Chronograph	31
10221 3NM	BUINO	CO-1	Chronograph	31
10225 37R	BRIR	CO-1	Chronolady	34
10225 37RB	BIR	CO-1	Chronolady	34
10225 3B	BIN	CO-1	Chronolady	34
10225 3B	BUIN	CO-1	Chronolady	34
10225 3N	BUIN	CO-1	Chronolady	34
10226 357JBUCA	BUID	Grand Ocean	Chronograph	19
10226 357RCA	NIR	Grand Ocean	Chronograph	19
10226 3BUCA	BUIN	Grand Ocean	Chronograph	19
10226 3CA	NBUN	Grand Ocean	Chronograph	19

REFERENCE	COLLECTION	NAME	P.	
10227 357RNCA	NBR	Chronorally-S	Chronograph	61
10227 37RCA	ABR	Chronorally-S	Chronograph	61
10227 3CA	NBN	Chronorally-S	Chronograph	61
10227 3M	ABN	Chronorally-S	Chronograph	60
10227 3M	NBN	Chronorally-S	Chronograph	60
10227 3NBUCA	BUBN	Chronorally-S	Chronograph	61
10227 3NBUM	BUBN	Chronorally-S	Chronograph	60
10227 TINCA	NINN	Chronorally-S	Chronograph	61
10229 357NRCA	NIR	Chronorally-S	Chronograph	63
10229 37RCA	AIR	Chronorally-S	Chronograph	63
10229 3CA	NIN	Chronorally-S	Chronograph	63
10229 3M	AIN	Chronorally-S	Chronograph	62
10229 3M	NIN	Chronorally-S	Chronograph	62
10229 3NBUCA	BUIN	Chronorally-S	Chronograph	63
10229 3NBUM	BUIN	Chronorally-S	Chronograph	62
10302 3	AIN	Chronorally	Chronorally	48
10302 3	BUIN	Chronorally	Chronorally	49
10302 3	GIN	Chronorally	Chronorally	49
10302 3	GR3	Chronorally	Chronorally	45
10302 3	NIN2	Chronorally	Chronorally	48
10302 37N	GIN	Chronorally	Chronorally	49
10302 37N	NIN	Chronorally	Chronorally	48
10302 37NJ	NOJ3	Chronorally	Chronorally	45
10302 3M	AIN	Chronorally	Chronorally	46
10302 3M	BUIN	Chronorally	Chronorally	46
10302 3M	GIN	Chronorally	Chronorally	46
10302 3M	NIN2	Chronorally	Chronorally	46
10302 3MV	GIN	Chronorally	Chronorally	46
10302 3V	GIN	Chronorally	Chronorally	48
10302 3V2	BUY3	Chronorally	Chronorally	45
10305 3NV	NV	Chronorally 1	Chronorally	55
10305 3NYM	NV	Chronorally 1	Chronorally	55
10411 37N	NANN	CO-1	Chronolady	35
10411 37NR120D	NANN	CO-1	Chronolady	35
10501 3	AIN	Les Bémonts	Chronograph Complication	118
10501 3	BUIN	Les Bémonts	Chronograph Complication	118
10501 37J	AID	Les Bémonts	Chronograph Complication	118
10501 37R	AIR	Les Bémonts	Chronograph Complication	118
10501 37R	GIR	Les Bémonts	Chronograph Complication	118
38001 TIN	AIN	Chronorally	Chronorally	44
38001 TIN	NIN	Chronorally	Chronorally	44
38001 TINBU1	BUIB1	Chronorally	Chronorally	44
38001 TINN1	NIBU1	Chronorally	Chronorally Limited Edition	40
40002 3	AIN	Les Bémonts	Moon Phase Complication	123
40002 3	AR	Les Bémonts	Moon Phase Complication	123
40002 3	BUIN	Les Bémonts	Moon Phase Complication	123
40002 3	NIN	Les Bémonts	Moon Phase Complication	123
40002 37J	AID	Les Bémonts	Moon Phase Complication	122
40002 37J	AR	Les Bémonts	Moon Phase Complication	122
40002 37R	AIR	Les Bémonts	Moon Phase Complication	122
40002 37R	AR	Les Bémonts	Moon Phase Complication	122
40002 37R	BUIR	Les Bémonts	Moon Phase Complication	122
53005 37GRM	GIR	Delfin The Original	3-Hands	78
53005 3BUM	AIN	Delfin The Original	3-Hands	78
53005 3M	AIN	Delfin The Original	3-Hands	78
53005 3M	BUIN	Delfin The Original	3-Hands	78
53005 3M	NIN	Delfin The Original	3-Hands	78

REFERENCE	COLLECTION	NAME	P.
54004 37GRM GIR	Delfin The Original	3-Hands	79
54004 3BUM AIN	Delfin The Original	3-Hands	79
54004 3M AIN	Delfin The Original	3-Hands	79
54004 3M BUIB	Delfin The Original	3-Hands	79
54004 3M NAIN	Delfin The Original	3-Hands	79
54004 3M NIN	Delfin The Original	3-Hands	79
56001 3 AIN	Les Bémonts	Slim Line Date	130
56001 3 GIN	Les Bémonts	Slim Line Date	130
56001 3 NAIN	Les Bémonts	Slim Line Date	130
56001 37J AID	Les Bémonts	Slim Line Date	128
56001 37J DI	Les Bémonts	Slim Line Date	128
56001 37R AIR	Les Bémonts	Slim Line Date	127
56001 37R GIR	Les Bémonts	Slim Line Date	127
56001 37R NAIR	Les Bémonts	Slim Line Date	127
56001 37R ROIR	Les Bémonts	Slim Line Date	128
56001 37RM AIR	Les Bémonts	Slim Line Date	126
56001 37RM GIR	Les Bémonts	Slim Line Date	126
56001 37RM NAIR	Les Bémonts	Slim Line Date	126
56002 357RC NIR	Grand Ocean	Ultra Slim	21
56002 37JC AID	Grand Ocean	Ultra Slim	21
56002 3C AIN	Grand Ocean	Ultra Slim	21
56002 3C BUIB	Grand Ocean	Ultra Slim	21
56002 3C NIN	Grand Ocean	Ultra Slim	21
57001 3 AIN	Les Bémonts	Slim Line Date	130
57001 3 GIN	Les Bémonts	Slim Line Date	130
57001 3 NAIN	Les Bémonts	Slim Line Date	130
57001 37J AID	Les Bémonts	Slim Line Date	128
57001 37J DI	Les Bémonts	Slim Line Date	128
57001 37R AIR	Les Bémonts	Slim Line Date	127
57001 37R GIR	Les Bémonts	Slim Line Date	127
57001 37R NAIR	Les Bémonts	Slim Line Date	127
57001 37R ROIR	Les Bémonts	Slim Line Date	128
57001 37RM AIR	Les Bémonts	Slim Line Date	126
57001 37RM GIR	Les Bémonts	Slim Line Date	126
57001 37RM NAIR	Les Bémonts	Slim Line Date	126
57002 357RC AIR	LaPassion	2-Hands	98
57002 357RC AR	LaPassion	2-Hands	98
57002 357RC NIR	LaPassion	2-Hands	98
57002 357RM AIR	LaPassion	2-Hands	98
57002 357RM AR	LaPassion	2-Hands	98
57002 357RM NIR	LaPassion	2-Hands	98
57002 37RC AIR	LaPassion	2-Hands	96
57002 37RC AR	LaPassion	2-Hands	96
57002 37RC BRIR	LaPassion	2-Hands	96
57002 37RC NIR	LaPassion	2-Hands	97
57002 37RC ROUIR	LaPassion	2-Hands	97
57002 37RM AIR	LaPassion	2-Hands	96
57002 37RM AR	LaPassion	2-Hands	96
57002 37RM BRIR	LaPassion	2-Hands	96
57002 37RM NIR	LaPassion	2-Hands	97
57002 3C AIN	LaPassion	2-Hands	100
57002 3C AR	LaPassion	2-Hands	100
57002 3C BUIB	LaPassion	2-Hands	100
57002 3C NIN	LaPassion	2-Hands	101
57002 3C ROIN	LaPassion	2-Hands	101
57002 3M AIN	LaPassion	2-Hands	100
57002 3M AR	LaPassion	2-Hands	100
57002 3M BUIB	LaPassion	2-Hands	100
57002 3M NIN	LaPassion	2-Hands	101
57002 3M ROIN	LaPassion	2-Hands	101

REFERENCE	COLLECTION	NAME	P.
64012 3 AIN	Les Bémonts	Big Date Small Second	125
64012 3 NIN	Les Bémonts	Big Date Small Second	125
64012 37R AIR	Les Bémonts	Big Date Small Second	124
64012 37R NIR	Les Bémonts	Big Date Small Second	124
64012 37R ROIR	Les Bémonts	Big Date Small Second	124
64012 37RM AIR	Les Bémonts	Big Date Small Second	124
64012 37RM NIR	Les Bémonts	Big Date Small Second	124
80077 3 ABN	Grand Ocean	Chronometer	15
80077 3 NBN	Grand Ocean	Chronometer	15
80094 3 NN	Chronorally 1	Automatic	54
80094 3N NV	Chronorally 1	Automatic	54
80099 37R NIR	CO-1	Offshore-1 Professional	28
80099 3M NIN	CO-1	Offshore-1 Professional	28
80099 3O NINO	CO-1	Offshore-1 Professional	28
80099 3OM NINO	CO-1	Offshore-1 Professional	28
80099 3R NIN	CO-1	Offshore-1 Professional	28
80099 3RM NIN	CO-1	Offshore-1 Professional	28
83015 3 BIN	Les Bémonts	Day Date	115
83015 3 BUIB	Les Bémonts	Day Date	115
83015 3 NIN	Les Bémonts	Day Date	115
83015 37R BIR	Les Bémonts	Day Date	114
83015 37R BUIR	Les Bémonts	Day Date	114
83015 37R NIR	Les Bémonts	Day Date	114
83015 37RM BIR	Les Bémonts	Day Date	114
83015 37RM BUIR	Les Bémonts	Day Date	114
83015 37RM NIR	Les Bémonts	Day Date	114
84300 37RCA NBR	Chronorally-S	3-Hands	65
84300 3CA ABN	Chronorally-S	3-Hands	65
84300 3CA NBN	Chronorally-S	3-Hands	65
84300 3M ABN	Chronorally-S	3-Hands	64
84300 3M NBN	Chronorally-S	3-Hands	64
84300 3NBUCA BUBN	Chronorally-S	3-Hands	65
84300 3NBUM BUBN	Chronorally-S	3-Hands	64
85008 3 NIN	Grand Ocean	Open Heart Automatic	15
85012 3 AIN	Grand Ocean	Open Vision Automatic	18
85012 357J AID	Grand Ocean	Open Vision Automatic	18
85012 357JN NID	Grand Ocean	Open Vision Automatic	18
85012 357N NIN	Grand Ocean	Open Vision Automatic	18
85013 3 AIN	Grand Ocean	Open Vision Automatic	17
85013 3 NIN	Grand Ocean	Open Vision Automatic	17
85013 357J AID	Grand Ocean	Open Vision Automatic	17
85014 3 AIN	Les Vauberts	Open Heart Automatic	136
85014 3 NIN	Les Vauberts	Open Heart Automatic	136
85014 37R AIR	Les Vauberts	Open Heart Automatic	136
85014 37R GIR	Les Vauberts	Open Heart Automatic	136
85019 37RA AIR	Les Vauberts	Open Heart	137
85019 37RA NADR	Les Vauberts	Open Heart	137
85019 37RG GIR	Les Vauberts	Open Heart	137
85019 3A AIN	Les Vauberts	Open Heart	137
85019 3A NADN	Les Vauberts	Open Heart	137
85019 3N NIN	Les Vauberts	Open Heart	137

REFERENCE	COLLECTION	NAME	P.
85021 3 AIN	Les Bémonts	Open Heart	117
85021 3 BUIB	Les Bémonts	Open Heart	117
85021 3 NIN	Les Bémonts	Open Heart	117
85021 37R AIR	Les Bémonts	Open Heart	116
85021 37R BUIR	Les Bémonts	Open Heart	116
85021 37R NIR	Les Bémonts	Open Heart	116
85021 37RM AIR	Les Bémonts	Open Heart	116
85021 37RM BUIR	Les Bémonts	Open Heart	116
85021 37RM NIR	Les Bémonts	Open Heart	116
85024 37GRM GIR	Delfin The Original	Open Heart	72
85024 3BUM AIN	Delfin The Original	Open Heart	72
85024 3M AIN	Delfin The Original	Open Heart	72
85024 3M BUIB	Delfin The Original	Open Heart	72
85024 3M NIN	Delfin The Original	Open Heart	72
85025 357RC AIR	LaPassion	Open Heart	86
85025 357RC ARR	LaPassion	Open Heart	86
85025 357RC NIR	LaPassion	Open Heart	86
85025 357RM AIR	LaPassion	Open Heart	86
85025 357RM ARR	LaPassion	Open Heart	86
85025 357RM NIR	LaPassion	Open Heart	86
85025 37RC AIR	LaPassion	Open Heart	84
85025 37RC ARR	LaPassion	Open Heart	84
85025 37RC BRIR	LaPassion	Open Heart	84
85025 37RC NIR	LaPassion	Open Heart	85
85025 37RC ROUIR	LaPassion	Open Heart	85
85025 37RM AIR	LaPassion	Open Heart	84
85025 37RM ARR	LaPassion	Open Heart	84
85025 37RM BRIR	LaPassion	Open Heart	84
85025 37RM NIR	LaPassion	Open Heart	85
85025 3C AIN	LaPassion	Open Heart	88
85025 3C ARN	LaPassion	Open Heart	88
85025 3C BUIB	LaPassion	Open Heart	88
85025 3C NIN	LaPassion	Open Heart	89
85025 3C ROIN	LaPassion	Open Heart	89
85025 3M AIN	LaPassion	Open Heart	88
85025 3M ARN	LaPassion	Open Heart	88
85025 3M BUIB	LaPassion	Open Heart	88
85025 3M NIN	LaPassion	Open Heart	89
85025 3M ROIN	LaPassion	Open Heart	89
85300 3 AIN	Les Bémonts	Automatic Shade Of Time	113
85300 3 BUIB	Les Bémonts	Automatic Shade Of Time	113
85300 3 NIN	Les Bémonts	Automatic Shade Of Time	113
85300 37J AID	Les Bémonts	Automatic Shade Of Time	113
85300 37R AIR	Les Bémonts	Automatic Shade Of Time	113
85300 37R GIR	Les Bémonts	Automatic Shade Of Time	113
85301 3 AIN	Grand Ocean	Automatic Phantom Of Time	13
85301 3 GIN	Grand Ocean	Automatic Phantom Of Time	13
85301 357RN NIR	Grand Ocean	Automatic Phantom Of Time	13
85301 37J AID	Grand Ocean	Automatic Phantom Of Time	13
88002 357RCA AIR	Grand Ocean	Automatic Day Date	14
88002 357RCA NIR	Grand Ocean	Automatic Day Date	14
88002 3CA NIN	Grand Ocean	Automatic Day Date	14
88002 3ORCA ABUN	Grand Ocean	Automatic Day Date	14
88004 3 NIN	Delfin The Original	Delfin Fleet 1650 Limited Edition	71
88004 BRZBU BUI	Delfin The Original	Delfin Fleet 1650 Limited Edition	71
95005 3 AIR	Les Bémonts	Les Bémonts C. R. F. Limited Edition	106







**EDOXIONARY**  
FOR WATCH PROFESSIONALS  
**2017 - 2018**



Maître Horloger - Les Genevez  
depuis 1884





## TIMING FOR CHAMPIONS

<b>MILESTONES</b>	THE EDOX HISTORY	4
<b>SPORTING INSTRUMENTS</b>	GRAND OCEAN – SPIRIT OF THE OCEAN	8
	CO-1 – OFFSHORE INSTRUMENTS	22
	CHRONORALLY – THE DRIVER’S INSTRUMENT	36
	CHRONORALLY 1 – RALLY INSTRUMENTS	50
	CHRONORALLY-S – INSTRUMENTS FOR THE SAUBER F1 TEAM	56
	DELFIN THE ORIGINAL – THE WATER CHAMPION WATCH	66
<b>STYLE &amp; ELEGANCE</b>	LAPASSION – FOR THE ART OF LIVING	80
	LES BÉMONTS – STYLE & ELEGANCE	102
	LES VAUBERTS – TRADITION OF 4 CENTURIES	132
<b>MARKETING &amp; MORE</b>		138
	COMPANY PRESENTATION	141
	FRIENDS AND PARTNERSHIPS	142
	VISUAL ADVERTISING WINNERS	144
	SOCIAL MEDIA	147
	THE 7 COMPETENCES OF EDOX	148
<b>POS MATERIAL</b>		150
	DISPLAYS	152
	SHOP IN SHOP	155
	DISPLAY ACCESSORIES	156
	PACKAGING – CATALOGUES – CERTIFICATES	157
	WALL CLOCK – GIVE-AWAYS	158
<b>TECHNICAL INFORMATION</b>		160
	EDOX QUALITY	162
	CLASP & BUCKLE	164
	MOVEMENTS	169
	REFERENCE NUMBER SYSTEM	175
COLLECTION OVERVIEW		
REFERENCES LIST		Cover flap
PICTOGRAMS		Back cover flap

## THE EDOX HISTORY



### **CHRISTIAN RUEFLI-FLURY**

#### **FOUNDER OF EDOX**

- 1860 Born in Courrendlin (Switzerland), son of a foundry master. Educated in Courrendlin.
- 1870 Moved to Grenchen (Switzerland). Commenced horology apprenticeship with Urs Schild, one of the great Master Watchmakers, before joining the Eterna watch company.
- 1883 Married Pauline Flury. Worked for Jean Ægler - watchmaker in Biel/Bienne until 1883.
- 1884 Founded his own watchmaking atelier in Biel/Bienne. Principal founder of the Lake Biel-Bienne Steam Boat Company and originator of the Evilard funicular and the Wildermeth Hospital in Biel/Bienne. Made numerous significant donations to regional hospitals and to children's nurseries in Biel/Bienne and gave monetary support to retirement homes and sanatoriums for the hard of hearing.

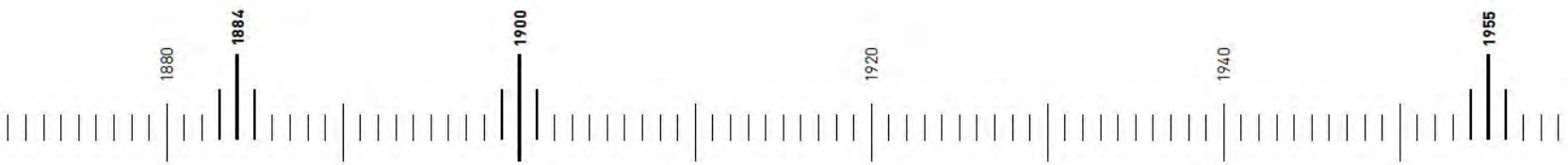
**1884**

### IT ALL BEGAN WITH A TRUE LOVE STORY

Christian Ruefli-Flury, a highly talented and romantic watchmaker "Maître-Horloger" from Grenchen in Switzerland, produces a pocket watch for the 25th birthday of his beloved wife Pauline. Impressed by this exquisite gift, she convinces her husband to set up his own watch making company in Biel, a city famous for its well-educated watch engineers. Christian Ruefli-Flury called his company "Edox" which means "measuring of time" in ancient Greek.

**1900**

### THE BIRTH OF A LOGO

The hourglass was officially used as a timeless symbol of Edox and since then, it has been a proud part of the official Edox company logo.

**1955**

### A GROWING COMPANY

At that time, Edox employed up to 500 watchmakers and the company moved into new, modern and larger production facilities. Edox was amongst Switzerland's leading watch companies.



**1961**  
THE WATER CHAMPION

The famous “Delfin” timepiece was launched, featuring a double caseback, special protective gaskets and a specially invented double O’ring system, setting new standards of shock protection and water resistance.

**1965**  
HYDRO-SUB

The revolutionary Hydro-Sub collection was launched, featuring the famous double O’crown patented Edox gasket for increased water resistance.

**1970**  
THE FIRST GENUINE  
WORLD TIME WATCH

This year saw the introduction of the world’s first truly global timepiece, the “Geoscope” watch. Covering all time zones, the watch provided timekeeping for almost 50 different cities around the world, as well as local time.

**1998**  
WORLD RECORD STILL  
UNBROKEN

Edox engineers and watch-makers developed the world’s slimmest calendar watch, the “Les Bémonts Ultra Slim” collection. The movement had a thickness of only 1.4 mm, which is a technical record still held by Edox to this day.

2010

2013

2015

2016

2017



**2010**

**THE TIMEKEEPER**

Edox becomes the official WRC timekeeper and launches a new collection dedicated to rally drivers, true virtuosos of the tarmac, snow and ice, and to all devotees of the automobile and motor-racing world.

**2016**

**Sauber F1® Team**

Edox is the official Premium Partner of **Sauber F1® Team** and steps in the thrilling world of Formula 1.

A new collection dedicated to this prestigious partner is also launched in 2016. This partnership is a strong testimony of Edox's presence amongst the most renowned and active Swiss watch brands.

**2016**

**NEW FACTORY**

Due to growing production demand, the factory capacity has expanded with a second floor.

**2017**

**FLEET 1650 PROJECT**

Edox has decided to underwrite the quest to protect World Maritime Heritage and to support the research of the Tjigger shipwreck in two 2017 maritime operations. The new Delfin Fleet 1650 Limited Edition timepieces illustrate this new partnership.

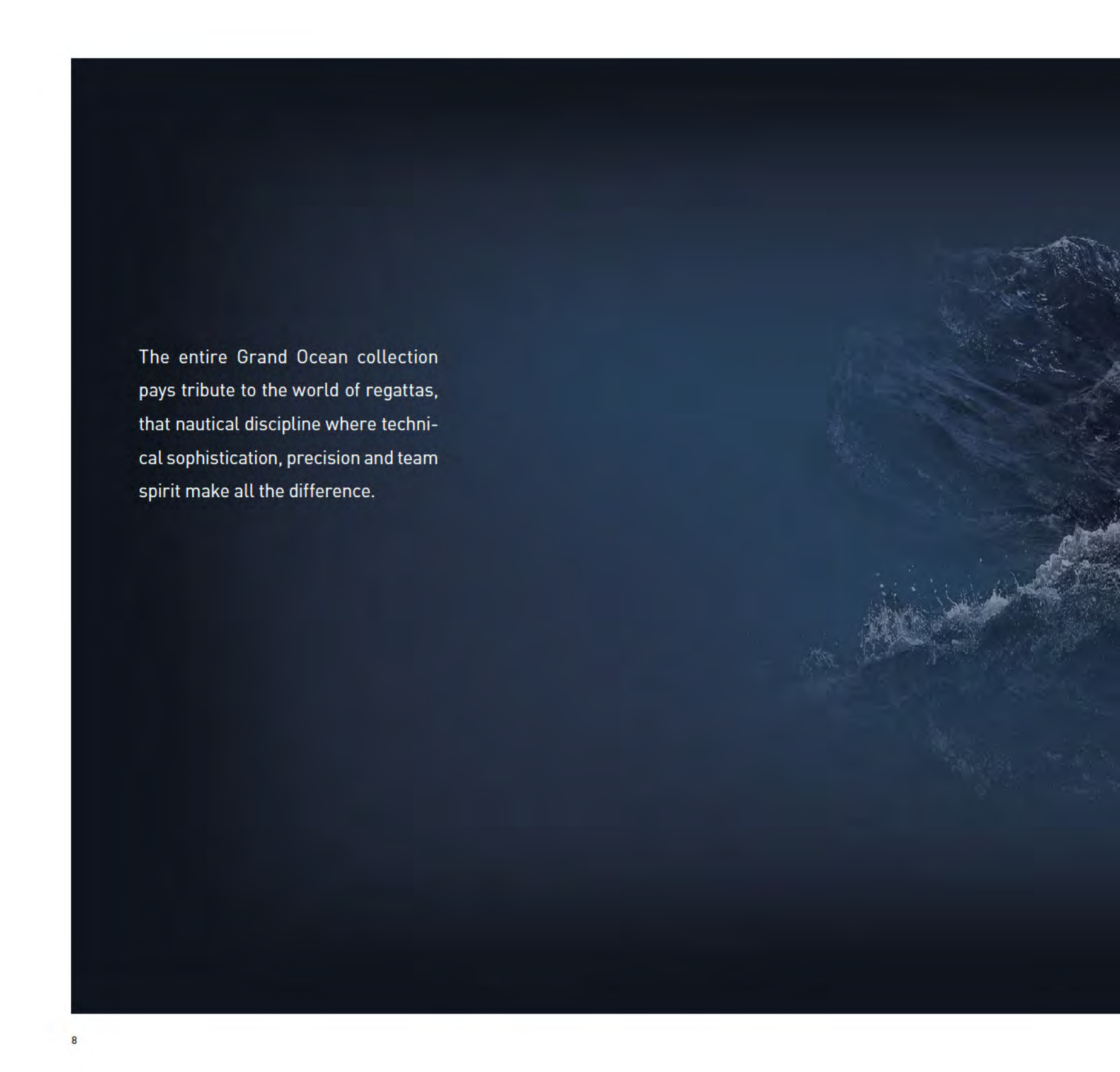

The entire Grand Ocean collection  
pays tribute to the world of regattas,  
that nautical discipline where techni-  
cal sophistication, precision and team  
spirit make all the difference.

# GRAND OCEAN

SPIRIT OF THE OCEAN





SKIPPER SAIL PORTUGAL

“  
*When sailing race request precision and full reliability, and thanks to its knowledge and engineering reliability, Edox proposes timepieces that are fully in adequation with the sailing world.*  
”





1 Crown equipped with double O-ring for perfect water-resistance  
 Couronne équipée d'un double joint pour une étanchéité parfaite  
 Krone mit Doppel-O-Ring-Dichtung für perfekte Wasserdichtheit  
 Corona con doble junta para una perfecta resistencia al agua  
 ダブルOリングを備えたリューズにより優れた防水性能を発揮します。  
 配備完美防水的雙防水圈錶冠  
 Заводная головка оснащена двойной O-прокладкой для идеальной водонепроницаемости

تم تزويد التاج بملحنتين لمنع التسرب للحصول على مقاومة مائية مثالية



01123 3BUCA NBUN Ø 45 MM

2 Hand design like a compass needle  
 Aiguilles au design de boussole  
 Zeigerdesign im Stil einer Kompassnadel  
 Diseño de manecilla como una aguja de brújula  
 コンパス針のようなデザインの針  
 羅盤指南針概念計時指針  
 Дизайн стрелок как у компаса

ميناہ مصمم على شكل بوصلة

3 Typical Grand Ocean triple horn design  
 Design Grand Ocean typique à triple corne  
 Dreiteiliger Bandanstoss, typisch für die Grand Ocean  
 Diseño típico de Grand Ocean con tres asas  
 グランドオーシャンの特徴のトリプルホーン(三股)デザイン  
 帆船系列具特有的三叉錶殼設計  
 Типичный для Grand Ocean дизайн с тройными ушками

تصميم القرون الثلاثة المميز لعلامة Grand Ocean

4 Transparent caseback  
 Boîtier avec fond transparent  
 Durchsichtiger Gehäuseboden  
 Tapa transparente  
 シースルーケースバック  
 透明後底蓋  
 Прозрачная крышка

غطاء خلفي شفاف مع نقش خريطة العالم



CHRONOGRAPH AUTOMATIC  
01121 357RN GIR Ø 48 MM



CHRONOGRAPH AUTOMATIC  
01123 357RCA NBUR Ø 45 MM



CHRONOGRAPH AUTOMATIC  
01123 30RCA ABUN Ø 45 MM



CHRONOGRAPH AUTOMATIC  
01123 3BUCA NBUN Ø 45 MM



AUTOMATIC PHANTOM OF TIME **NEW**  
85301 357RN NIR Ø 41 MM



AUTOMATIC PHANTOM OF TIME **NEW**  
85301 37J AID Ø 41 MM



AUTOMATIC PHANTOM OF TIME **NEW**  
85301 3 AIN Ø 41 MM



AUTOMATIC PHANTOM OF TIME **NEW**  
85301 3 GIN Ø 41 MM









Grand Ocean casebacks also feature a world map engraving, linking the collection to the yachting world.







22mm  
12.5mm  
121g

CHRONOGRAPH  
10226 357JBUCA BUID Ø 45 MM



22mm  
12.5mm  
121g

CHRONOGRAPH  
10226 357RCA NIR Ø 45 MM





22mm  
12.5mm  
121g

CHRONOGRAPH  
10226 3BUCA BUIN Ø 45 MM



22mm  
12.5mm  
121g

CHRONOGRAPH  
10226 3CA NBUN Ø 45 MM





Offshore pilots are real heroes of extreme water races.

They have to keep their nerves under all circumstances, have perfect timing reaction and ensure the perfect race and aim for the title. The speed sometimes reaches a breathtaking 270 km/h. What pilots often say is “What you see in front of you is already history”.

**CO-1**

OFFSHORE INSTRUMENTS

CO-1





PAL VIRIK NILSEN, PROFESSIONAL POWERBOAT PILOT:

“  
 My CO-1 reflects my sport and my offshore racing boat: robust, water resistant, shock-resistant and with high-precision movement.”



1 Strong and ultra-solid case construction  
 Boîtier ultrasolide  
 Solide, ultrarobuste Gehäusekonstruktion  
 Caja ultrasólida y fuerte  
 屈強で堅牢なケース構造  
 堅固耐用的錶殼結構設計  
 Сильная и ультра-прочная конструкция корпуса  
 عالية ذات بنية قوية وصلبة للغاية

2 3 mm thickness of sapphire crystal  
 Épaisseur du verre saphir de 3 mm  
 3 mm dickes Saphirglas  
 Cristal de zafiro de 3 mm  
 3mm厚のサファイアクリスタル  
 3毫米厚的藍寶石水晶鏡面  
 Сапфировое стекло толщиной 3 мм  
 زجاجة كريستال بلوري بسمك ٣ م

- 4 Automatic Helium valve for specific deep sea diving  
 Valve à hélium automatique spécifiquement conçue pour la plongée en eau profonde  
 Automatisches Heliumventil für Tieftauchgänge  
 Válvula automática de helio para inmersión profunda  
 本格的な深海ダイビングのためのオートヘリウムバルブ  
 特別為深海潛水設計的自動排氦  
 Автоматический гелиевый клапан для глубоководного погружения

صمام هيليوم أوتوماتيكي خاص بالغوص في أعماق البحار



01122 37R NIR Ø 45 MM

- 5 Scratch resistant ceramic bezel with 120 clicks  
 Lunette en céramique 120 clics résistante aux rayures  
 Kratzfeste Keramiklunette mit 120 Einrastpositionen  
 Engaste de cerámica resistente a los arañazos, de 120 clics  
 120クリックの耐傷性に優れたセラミックベゼル  
 精密耐磨損旋轉120刻度的陶瓷外圍  
 Устойчивый к царапинам керамический безель с 120 зубьями трещотки

حافة من السيراميك المقاوم للخدش مع ١٢٠ سقاطة

- 5 Offshore boat propeller engraving on the thick caseback  
 Hélice de hors-bord gravée sur le dos du boîtier de 2.2 mm d'épaisseur  
 2.2 mm dicker Gehäuseboden mit Gravur einer Offshore-Racer-Schiffsschraube  
 Grabado de hélice de barco en la tapa  
 オフショアボートのプロペラが刻印された 2.2mm厚ケースバック  
 快艇螺旋槳立體圖騰鐫刻旋槳式後底蓋  
 Гравировка пропеллера морского катера на задней крышке толщиной 2.2 мм

تشق مروحة القارب البحري على الغطاء الخلفي السميكة

CO-1 OFFSHORE INSTRUMENTS



CHRONOGRAPH AUTOMATIC  
01122 3M BUIN Ø 45 MM



CHRONOGRAPH AUTOMATIC  
01122 3NM BUINO Ø 45 MM



CHRONOGRAPH AUTOMATIC  
01122 3M NIN Ø 45 MM



CHRONOGRAPH AUTOMATIC  
01122 3 BUIN Ø 45 MM



CHRONOGRAPH AUTOMATIC  
01122 3N BUINO Ø 45 MM



CHRONOGRAPH AUTOMATIC  
01122 3 NIN Ø 45 MM





CHRONOGRAPH AUTOMATIC  
01122 3BNM BINN Ø 45 MM



CHRONOGRAPH AUTOMATIC  
01122 3BN BINN Ø 45 MM



CHRONOGRAPH AUTOMATIC  
01122 37R NIR Ø 45 MM

CO-1 OFFSHORE INSTRUMENTS



**OFFSHORE-1 PROFESSIONAL**  
80099 3M NIN Ø 43 MM



**OFFSHORE-1 PROFESSIONAL**  
80099 30M NINO Ø 43 MM



**OFFSHORE-1 PROFESSIONAL**  
80099 3RM NIN Ø 43 MM



**OFFSHORE-1 PROFESSIONAL**  
80099 37R NIR Ø 43 MM



**OFFSHORE-1 PROFESSIONAL**  
80099 30 NINO Ø 43 MM



**OFFSHORE-1 PROFESSIONAL**  
80099 3R NIN Ø 43 MM



CHRONOGRAPH **NEW**  
10221 37RBU7 BIR7 Ø 45 MM



CHRONOGRAPH **NEW**  
10221 37RBU7 BUIR7 Ø 45 MM



CHRONOGRAPH **NEW**  
10221 3BU7 BUIIN7 Ø 45 MM





25mm  
14mm  
150g

CHRONOGRAPH  
10221 357RM BINR Ø 45 MM



25mm  
14mm  
150g

CHRONOGRAPH  
10221 3NM BUINO Ø 45 MM



25mm  
14mm  
150g

CHRONOGRAPH  
10221 3M NIN Ø 45 MM



25mm  
14mm  
150g

CHRONOGRAPH  
10221 357R BINR Ø 45 MM



25mm  
14mm  
150g

CHRONOGRAPH  
10221 3N BUINO Ø 45 MM



25mm  
14mm  
150g

CHRONOGRAPH  
10221 3 NIN Ø 45 MM





25mm

14mm

150g

CHRONOGRAPH  
10221 37R NIR Ø 45 MM



25mm

14mm

150g

CHRONOGRAPH  
10221 37N NINJ Ø 45 MM

CO-1 OFFSHORE INSTRUMENTS



21mm

11mm

98g

CHRONOLADY  
10225 37R BRIR Ø 38 MM



21mm

11mm

98g

CHRONOLADY  
10225 37RB BIR Ø 38 MM



21mm

11mm

98g

CHRONOLADY  
10225 3N BUIN Ø 38 MM



21mm

11mm

98g

CHRONOLADY  
10225 3B BUIN Ø 38 MM



21mm

11mm

98g

CHRONOLADY  
10225 3B BIN Ø 38 MM





21mm

11mm

98g

CHRONOLADY  
10411 37NR120D NANN Ø 38 MM



21mm

11mm

98g

CHRONOLADY  
10411 37N NANN Ø 38 MM

Formula 1 drivers, such as Sauber F1® Team official ones, are enduring very difficult conditions: speed, adrenaline, danger, heat...

For professional drivers, wearing a Chronorally timepiece means a lot in terms of quality. Chronorally collection is built to withstand these harsh environment conditions.

# CHRONORALLY

THE DRIVER'S INSTRUMENT



CHRONORALLY



Sauber F1® Team

“  
*Edox and the Sauber F1®  
Team represent the perfect  
match of two traditional Swiss  
enterprises engineering world  
class products*”  
»

2

Carbone fibre dials for modernity and technical aspects  
Cadrans en fibre de carbone pour la modernité et la technicité  
Karbonzifferblätter unterstreichen die Modernität und die technischen  
Aspekte der Uhr  
Técnica y modernidad en las esferas de fibra de carbono  
モダンで機能的なカーボンファイバーダイアル  
具現代及科技感的碳纖維錶面  
Современный и высокотехнологичный карбоновый циферблат

عدادات ميناء من الألياف الكربونية لمظهر عصري ومميزات تقنية

3

Rubber strap with tyre imprints  
Bracelet en caoutchouc avec design empreintes de pneu  
Kautschukarmband mit Reifenprofil  
Correa de caucho con motivos de neumáticos  
タイヤ模様のラバーストラップ  
車胎紋矽橡膠帶  
Каучуковый ремешок с рисунком протектора шин

سوار مطاطي مزين برسوم العجلات

- ① Over-sized pusher for perfect grip on the watch commands  
 Poussoir de grande taille pour une maîtrise parfaite des fonctions de la montre  
 Besonders grosser Drücker für sicheren Zugriff auf die Uhrenfunktionen  
 Pusher de gran tamaño para una sujeción perfecta de los mandos  
 時計の操作がしやすい大型プッシュボタン  
 超大尺寸計時按把為手錶贏得十足的吸引力  
 Увеличенная кнопка хронографа для удобного использования часов

مكبس كبير لتحكم مثالي في ضبط الساعة



38001 TINN1 NIBU1 Ø 48 MM

- ④ Robust titanium construction for extreme use conditions  
 Construction en titane pour des conditions d'utilisation extrêmes  
 Robuste Titanausführung für Widerstandsfähigkeit unter Extrembedingungen  
 Construido en titanio macizo para condiciones extremas de uso  
 過酷な環境下にも耐え得る堅牢なスチール構造  
 堅硬鈦金屬結構適合用於激烈的情況下使用  
 Прочный титановый корпус для использования в экстремальных условиях

بنية من الفولاذ الصلب لتحمل ظروف الاستعمال القاسية



CHRONORALLY LIMITED EDITION Sauber F1 Team **NEW**  
38001 TINN1 NIBU1 Ø 48 MM  
LIMITED EDITION OF 555 PIECES WORLDWIDE

  
**EDOX**  
Swiss Watches

 Sauber F1 Team

PREMIUM PARTNER









CHRONORALLY THE DRIVER'S INSTRUMENT



Chronorally casebacks pays tribute to rally world and aficionados with special rubber inprint or tyre profile.





**CHRONORALLY THE DRIVER'S INSTRUMENT**



Such high pressure resistant case backs or comparable are used for the Chronorally collection.





# CHRONORALLY THE DRIVER'S INSTRUMENT



Such high pressure resistant case backs or comparable are used for the Chronorally collection.





CHRONORALLY  
10302 37N GIN Ø 45 MM



CHRONORALLY  
10302 3 GIN Ø 45 MM



CHRONORALLY  
10302 3 BUIN Ø 45 MM

Rally pilots, such as Edox ambassador and WRC pilot Martin Prokop from Czech Republic, are enduring very hard conditions: heat, dust, mud, sand... For professional pilots and all rally aficionados, wearing a Chronorally timepiece means a lot in terms of quality. Chronorally collection is built to withstand these harsh environment conditions.



# CHRONORALLY 1

RALLY INSTRUMENTS



CHRONORALLY-1

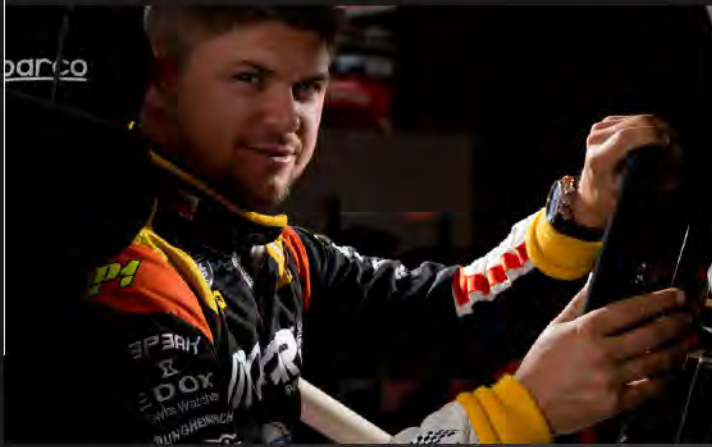

MARTIN PROKOP, WRC PILOT AND  
DAKAR RALLY PARTICIPANT:

“ Since I wear my Chronorally  
watch, it never fails. I need a  
watch that can withstand the  
crazy race conditions and  
my watch can do all that. ”

2

Carbone fibre dials for modernity and technical aspects  
Cadrans en fibre de carbone pour la modernité et la technicité  
Karbonzifferblätter unterstreichen die Modernität und die technischen  
Aspekte der Uhr  
Técnica y modernidad en las esferas de fibra de carbono  
モダンで機能的なカーボンファイバーダイヤル  
具現代及科技感的碳纖維錶面  
Современный и высокотехнологичный карбоновый циферблат

عدادات میناء من الألياف الكربونية لظهور عصري ومميزات تقنية

3

Rubber strap with tyre imprints  
Bracelet en caoutchouc avec design empreintes de pneu  
Kautschukarmband mit Reifenprofil  
Correa de caucho con motivos de neumáticos  
タイヤ模様のラバーストラップ  
車胎紋矽橡膠帶  
Каучуковый ремешок с рисунком протектора шин

سوار مطاطي مزين برسوم العجلات

- ① Over-sized pusher for perfect grip on the watch commands  
 Poussoir de grande taille pour une maîtrise parfaite des fonctions de la montre  
 Besonders grosser Drücker für sicheren Zugriff auf die Uhrenfunktionen  
 Pusher de gran tamaño para una sujeción perfecta de los mandos del reloj  
 時計の操作がしやすい大型プッシュボタン  
 超大尺寸計時按把為手錶贏得十足的吸引力  
 Увеличенная кнопка хронографа для удобного использования часов  
 مكبس كبير لتحكم مثالي في ضبط الساعة



01118 3 NO Ø 45 MM

- ② Robust material construction for extreme use conditions  
 Construction en acier solide pour des conditions d'utilisation extrêmes  
 Robuste Stahlausführung für Widerstandsfähigkeit unter Extrembedingungen  
 Robusta construcción en acero macizo para condiciones extremas de uso  
 過酷な環境下にも耐え得る堅牢なスチール構造  
 堅硬不銹鋼結構適合在激烈的情況下使用  
 Прочная стальная конструкция в экстремальных условиях использования  
 بنية من الفولاذ الصلب لتحمل ظروف الاستعمال القاسية

- ③ Transparent caseback offering the view on the movement  
 Dos du boîtier transparent pour visualiser le mouvement  
 Der durchsichtige Gehäuseboden gibt den Blick auf das Uhrwerk frei  
 Tapa transparente que permite ver el movimiento  
 ムーブメントの動きが観賞できるシースルーケースバック  
 鏤空可透視機芯後底蓋  
 я задняя крышка, открывающая вид на механизм  
 غطاء خلفي شفاف يمكن من مشاهدة الحركة

CHRONORALLY 1 RALLY INSTRUMENTS



The wide opening of the caseback allows a full view on the automatic movement. This movement is considered as the Rolls-Royce movement of the watchmaking industry.



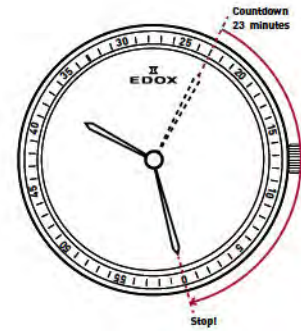

**BEZEL COUNTDOWN FUNCTION**  
With a countdown bezel, you rotate the bezel to a start time and when the minute hands reaches zero, the time is up.



Edox increase its expertise in producing timepieces that can endure harsh conditions and that Formula One fans can recognize as a indispensable watch to belong.

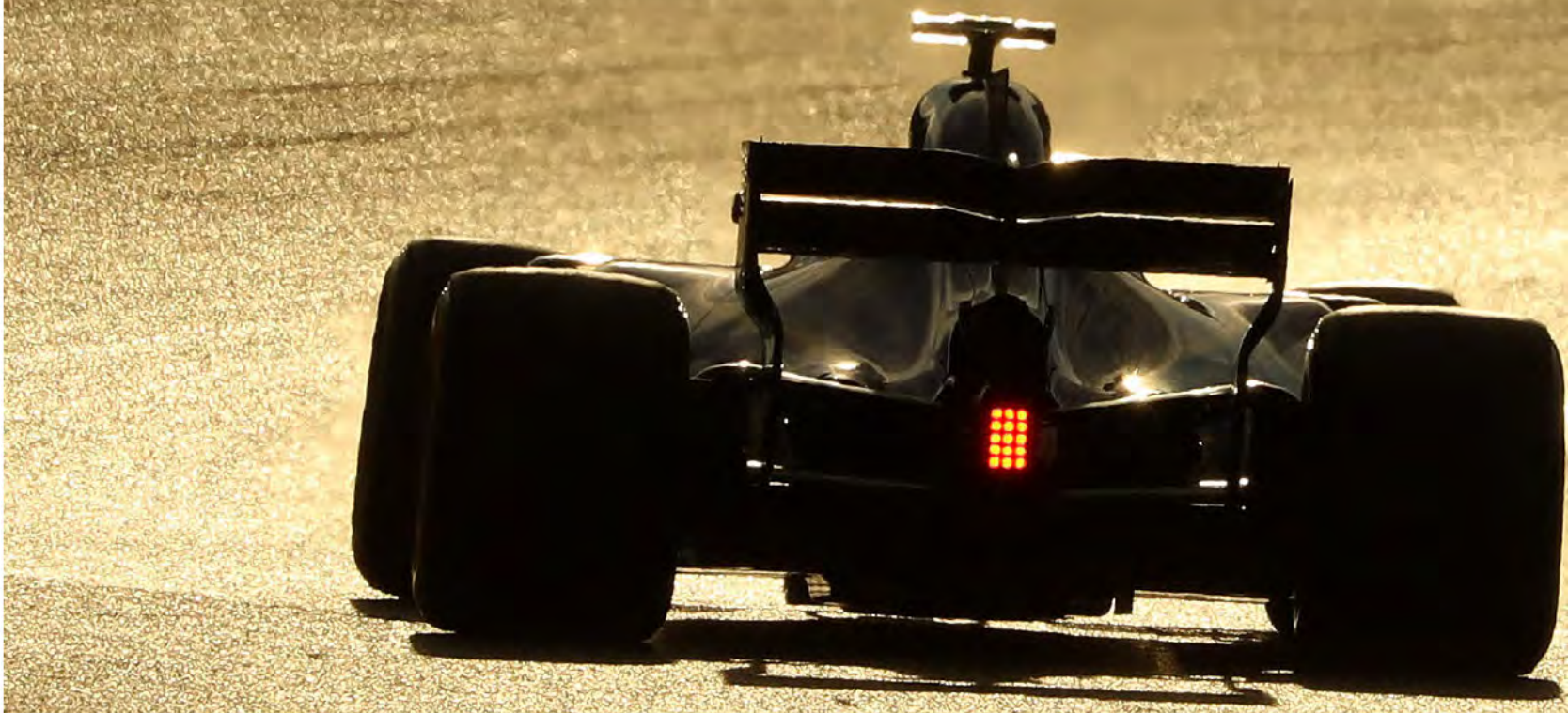

# CHRONORALLY-S

INSTRUMENTS FOR THE SAUBER F1® TEAM



CHRONORALLY-S



SAUBER F1® TEAM TRUSTS IN  
CHRONORALLY-S COLLECTION  
DNA AND STRONG ENGINEERING  
CAPACITIES.





10229 3NBUCA BUIIN Ø 44 MM

- The caseback features a splendid Formula One car.  
 Le fond est gravé avec une magnifique voiture de Formule 1  
 Auf der Gehäuserückseite ist die Abbildung eines Formel 1 Autos eingestanz  
 El fondo muestra un espléndido coche Fórmula 1  
 フォーミュラ1マシンを刻印したケースバック  
 錶後底蓋特徵有一部 F-1 賽車  
 На крышке корпуса - великолепный болид "Формулы-1"

شكل عربة فورمولا 1 على الغطاء الخلفي

- Tachymeter scale on the bezel for speed measuring  
 Echelle tachymétrique sur la lunette pour mesure de la vitesse  
 Tachymeterskala auf der Lünette für Geschwindigkeitsmessung  
 Escala de taquímetro en el bisel para medir la velocidad  
 速度測定用のタキメーター付きベゼル  
 錶圈上的測速儀可測量速度  
 Тахиметрическая шкала на безеле для измерения скорости

مقياس التاكيومتر على الإطار الدائري لقياس السرعة

CHRONORALLY-S INSTRUMENTS FOR THE SAUBER F1® TEAM



100% SWISS MADE  
 316L STAINLESS STEEL  
 10 ATM  
 20mm  
 13mm  
 127g

CHRONOGRAPH **NEW**  
 10227 3NBUM BUBN Ø 44 MM



100% SWISS MADE  
 316L STAINLESS STEEL  
 10 ATM  
 20mm  
 13mm  
 127g

CHRONOGRAPH **NEW**  
 10227 3M ABN Ø 44 MM



100% SWISS MADE  
 316L STAINLESS STEEL  
 10 ATM  
 20mm  
 13mm  
 127g

CHRONOGRAPH **NEW**  
 10227 3M NBN Ø 44 MM



CHRONOGRAPH **NEW**  
10227 TINCA NINN Ø 44 MM



CHRONOGRAPH **NEW**  
10227 37RCA ABR Ø 44 MM



CHRONOGRAPH **NEW**  
10227 357RCA NBR Ø 44 MM



CHRONOGRAPH **NEW**  
10227 3NBUCA BUBN Ø 44 MM



CHRONOGRAPH **NEW**  
10227 3CA NBN Ø 44 MM

CHRONORALLY-S INSTRUMENTS FOR THE SAUBER F1® TEAM





CHRONOGRAPH **NEW**  
10229 37RCA AIR Ø 44 MM



CHRONOGRAPH **NEW**  
10229 357NRCA NIR Ø 44 MM



CHRONOGRAPH **NEW**  
10229 3NBUCA BUIN Ø 44 MM



CHRONOGRAPH **NEW**  
10229 3CA NIN Ø 44 MM



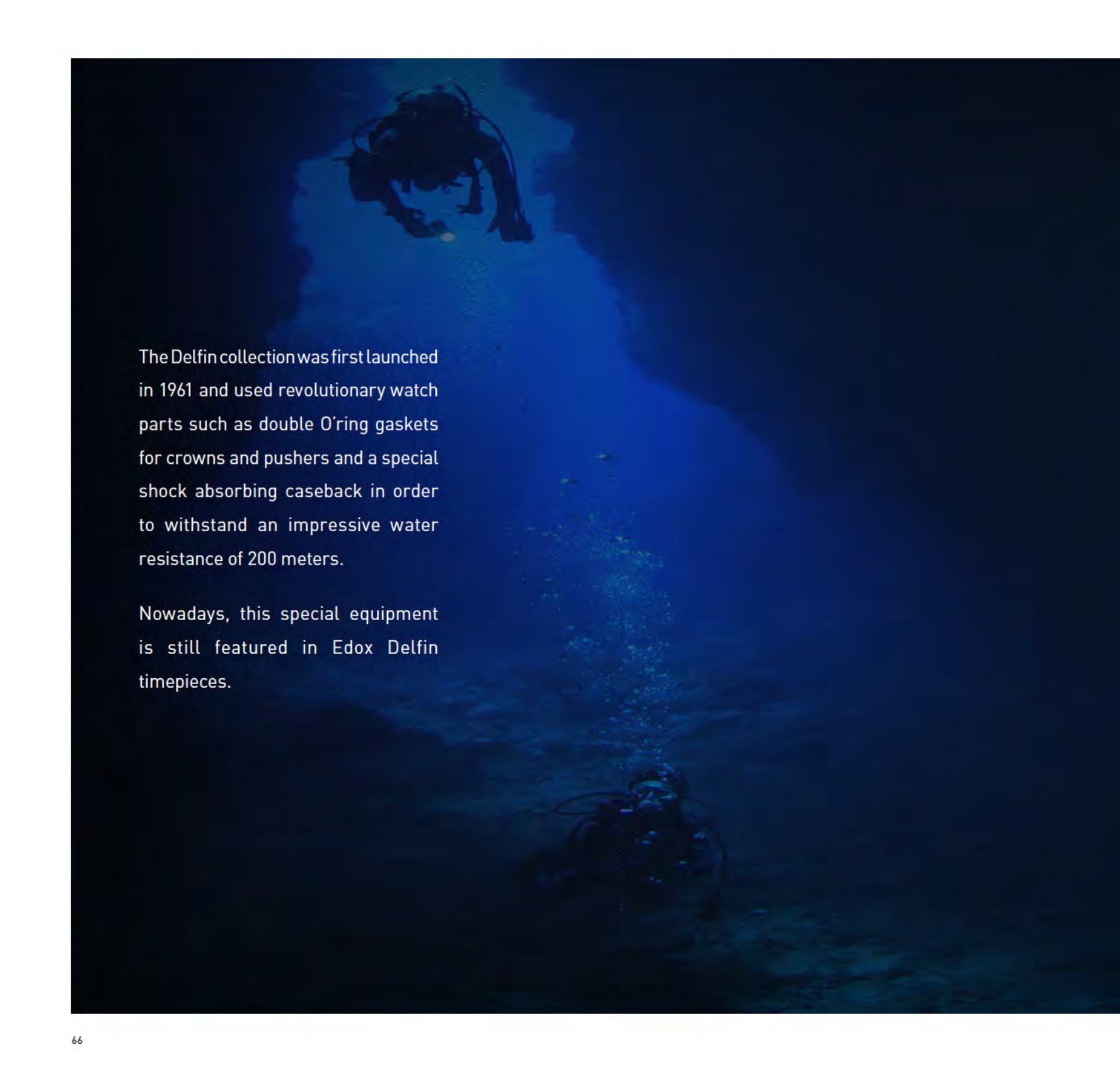

A deep blue underwater scene featuring two divers. One diver is positioned at the top center, and another is at the bottom center. A stream of bubbles rises from the bottom diver towards the top. The background is a dark, textured blue, suggesting a cave or deep sea environment.

The Delfin collection was first launched in 1961 and used revolutionary watch parts such as double O'ring gaskets for crowns and pushers and a special shock absorbing caseback in order to withstand an impressive water resistance of 200 meters.

Nowadays, this special equipment is still featured in Edox Delfin timepieces.



# DELFIN THE ORIGINAL

THE WATER CHAMPION WATCH



DELFIN

2 Double O-rings for crowns and pushers, special shock absorbing caseback  
Joints doubles pour la couronne et les poussoirs, fond spécial pour absorber les chocs  
Krone und Drücker mit Doppel-O-Ring-Dichtung; verstärkter Gehäuseboden für besondere Stossicherheit  
Juntas dobles en coronas y pushers, tapa especial con mayor protección antigolpes  
ダブルOリングを備えたリューズとプッシュボタン、耐衝撃性能のケースバック  
雙防水圈的錶冠及按把，特殊防震後蓋。  
Двойные O-прокладки заводных головок и кнопок хронографа, специальный амортизирующий корпус

حلقتان للتيجان والمكابس، وغطاء خلفي مصمم لامتصاص الصدمات

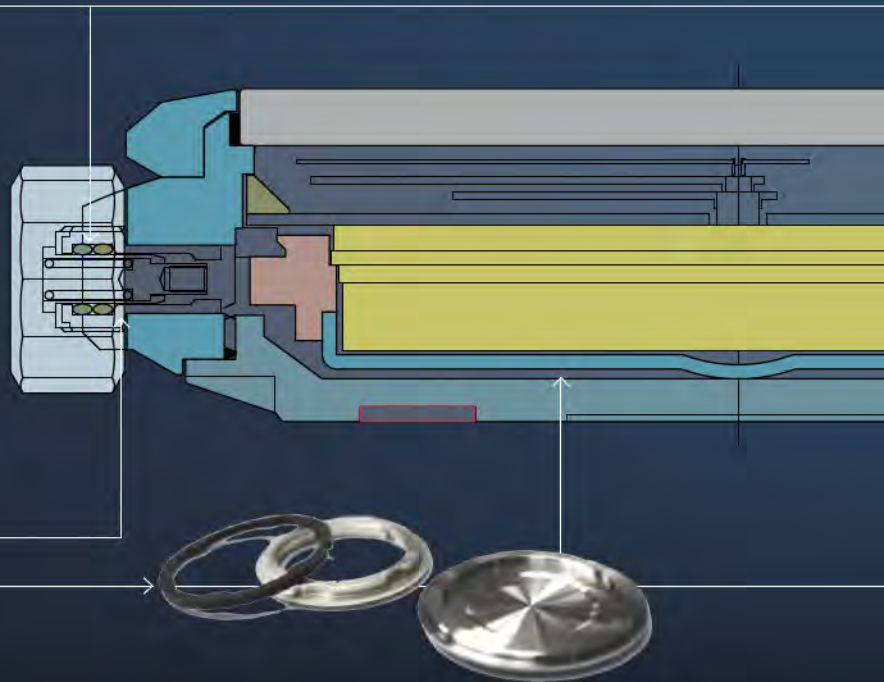

# DELFIN THE ORIGINAL

THE WATER CHAMPION WATCH

- 1 Superluminova applied on the hands and indices for reinforced luminescence (60% better than standard quality)  
 Superluminova appliqué sur les aiguilles et index pour une luminescence renforcée (60% meilleure que la qualité habituelle)  
 Indizes sowie Zeiger mit Leuchtmasse (Superluminova GL X1) beschichtet. Dies führt zu einer ca. 60% besseren Leuchtkraft gegenüber einer Standardqualität.  
 Supertuminova en agujas e índices para reforzar la luminiscencia (60% mejor que la calidad standard)  
 アップライドインデックスと針にスーパーミノヴァを採用。  
 (通常のルミノヴァよりも60%以上の発光)  
 加強夜光效果的指針與刻度。(比標準亮度高出60%)  
 Суперлюминова нанесена на стрелки и индексы для обеспечения более яркого свечения (на 60% лучше стандартного качества)

ملاء سوبرلومینوفا الفسفوري على عقارب الساعة وعلى الأرقام لإشارة قوية  
 (أقوى بـ ٦٠٪ من النوعية العادية)



- 2 Iconic design pays tribute to original Delfin of conceived in the 70's  
 Design iconique rendant hommage au modèle Delfin original conçu dans les années 70  
 Legendäres Design in Anlehnung an die Original-Delfin aus den 1970er-Jahren  
 El emblemático diseño rinde homenaje al Delfin original creado en los años setenta  
 70年代のデルフィンオリジナルモデルに敬意を表した象徴的なデザイン  
 代表性的設計向70年代的原創設計海王子致敬  
 Иконический дизайн отдает дань оригинальной модели Delfin, созданной в 1970-х гг.

تصميم أيقوني لتكريم علامة Delfin المبكرة في السبعينات

10109 357RNCA NIRG Ø 43 MM



# Fleet 1650

## SAVING WORLD MARITIME HERITAGE

Hundreds of wrecks around the busy sea-lanes of Indonesia's vast archipelago are particularly vulnerable. Every wreck has its own story and in order to pay tribute to men who protect these heritage sites, Edox will underwrite a fascinating project to reaserach, record and protect such sites.

The story begins in February 1650. 5 ships of the famed Dutch East India Company, led by the flagship Tijger stranded on the tiny sansback of Kabaena in Southeast Sulawesi (Indonesia). Only remains of Tijger and another yet unidentified vessel were discovered by a team of researches in April 2016. In 2017, the Arqueonautas Fashion Brand and the Indonesia's Bureau for the Protection of Cultural Heritage will conduct a survey on the site and try to confirm the Tijger remnants.

Edox is proud to support this detailed reconnaissance and survey on the site, exactly 367 years after Tijger and her sister ships were lost.

More information on [www.edox.ch/collections](http://www.edox.ch/collections).





-  MOON PHASE
-  DAY DATE
-  TIDE
-  COMPASS
-  TEMPERATURE
-  BAROMETER
-  20 ATM
-  22mm
-  14mm
-  120g

DELFIN FLEET 1650 LIMITED EDITION **NEW**  
 88004 BRZBU BUI Ø 43 MM  
 LIMITED EDITION OF 200 PIECES WORLDWIDE



-  MOON PHASE
-  DAY DATE
-  TIDE
-  COMPASS
-  TEMPERATURE
-  BAROMETER
-  20 ATM
-  22mm
-  14mm
-  115g

DELFIN FLEET 1650 LIMITED EDITION **NEW**  
 88004 3 NIN Ø 43 MM  
 LIMITED EDITION OF 300 PIECES WORLDWIDE

**BRONZE**

A fascinating material often associated with the sea. Bronze is highly resistant to the corrosive action of salted water and atmospheric components. It preserves its warm original tones, while acquiring a superb worn look, thanks to the patina which forms over time, making every watch unique.



**DELFIN THE ORIGINAL THE WATER CHAMPION WATCH**





DELFIN THE ORIGINAL THE WATER CHAMPION WATCH















20mm  
12mm  
162g

CHRONOGRAPH **NEW**  
10109 357RBUM NIR Ø 43 MM















20mm  
12mm  
162g

CHRONOGRAPH **NEW**  
10109 3M BUIN Ø 43 MM















20mm  
12mm  
162g

CHRONOGRAPH **NEW**  
10109 3M AIN Ø 43 MM















20mm  
12mm  
102g

CHRONOGRAPH **NEW**  
10109 357RNCA NIRG Ø 43 MM















20mm  
12mm  
102g

CHRONOGRAPH **NEW**  
10109 3CA BUIN Ø 43 MM















20mm  
12mm  
102g

CHRONOGRAPH **NEW**  
10109 3CA AIN Ø 43 MM

























20mm  
12mm  
162g

**CHRONOGRAPH NEW**  
10109 357JVM VID Ø 43 MM



20mm  
12mm  
162g

**CHRONOGRAPH NEW**  
10109 3M NIN Ø 43 MM













20mm  
12mm  
162g

**CHRONOGRAPH**  
10108 3BU AIN Ø 43 MM













20mm  
12mm  
102g



**CHRONOGRAPH NEW**  
10109 357GNCA NINB Ø 43 MM











20mm  
12mm  
102g

**CHRONOGRAPH NEW**  
10109 357NCA NIN Ø 43 MM

**DELFIN THE ORIGINAL THE WATER CHAMPION WATCH**



- Q QUALITY
- 30
- SWISS MADE
- STAINLESS STEEL
- PVD
- 20 ATM
- 20mm
- 12mm
- 162g

**CHRONOGRAPH NEW**  
10110 357JM AID Ø 43 MM



- Q QUALITY
- 30
- SWISS MADE
- STAINLESS STEEL
- PVD
- 20 ATM
- 20mm
- 12mm
- 102g

**CHRONOGRAPH NEW**  
10110 357JCA AID Ø 43 MM



- Q QUALITY
- 30
- SWISS MADE
- STAINLESS STEEL
- PVD
- 20 ATM
- 20mm
- 12mm
- 102g

**CHRONOGRAPH NEW**  
10110 357RCA AIR Ø 43 MM



- Q QUALITY
- 30
- SWISS MADE
- STAINLESS STEEL
- PVD
- 20 ATM
- 20mm
- 12mm
- 102g

**CHRONOGRAPH NEW**  
10110 357RNCA NIR Ø 43 MM



**DELFIN THE ORIGINAL THE WATER CHAMPION WATCH**



- 
- 
- 
- 
- 
- 
- 
- 20mm
- 10.4mm
- 97g

**3-HANDS**  
54004 37GRM GIR Ø 35 MM

- 
- 
- 
- 
- 
- 
- 20mm
- 10.4mm
- 97g

**3-HANDS**  
54004 3M AIN Ø 35 MM

- 
- 
- 
- 
- 
- 
- 20mm
- 10.4mm
- 97g

**3-HANDS**  
54004 3M BUIN Ø 35 MM

- 
- 
- 
- 
- 
- 
- 20mm
- 10.4mm
- 97g

**3-HANDS**  
54004 3M NIN Ø 35 MM

- 
- 
- 
- 
- 
- 
- 20mm
- 10.4mm
- 97g

**3-HANDS**  
54004 3M NAIN Ø 35 MM

- 
- 
- 
- 
- 
- 
- 20mm
- 10.4mm
- 97g

**3-HANDS**  
54004 3BUM AIN Ø 35 MM

DELFIN

When master watchmaker Christian Ruefli-Flury made a pocket watch in 1883 for his beloved wife Pauline, she influenced him to set up his own watch-making company: Edox.

It was a decision fuelled by vision, expertise – and love.

More than 130 years' on, Edox brings its watch-making passion, quality, craftsmanship and engineering to the fore the LaPassion collection.

Driven by superb and heart-warming feelings such as passion or love, the collection reflects the femininity and elegance that all ladies feel when they are beloved.

# LAPASSION

FOR THE ART OF LIVING







- 1 The shiny cabochon represent the symbol of eternity, elegance and femininity  
 Le cabochon brillant symbolise l'éternité, l'élégance et la féminité.  
 Der strahlende Cabochon steht als Symbol für das Unvergängliche, für Eleganz und Weiblichkeit  
 El brillante cabujón representa el símbolo de la eternidad, la elegancia y la feminidad  
 永遠とエレガンスと女性らしさを象徴する、輝くカボション  
 閃亮的寶石代表永恒、優雅的仕女風範  
 Ющий кабoшон на заводной головке выступает символом вечности, элегантности и женственности

تغل الأجار اللمعة رمز الخلود والأنقة والأموثة



85025 357RM AIR Ø 33 MM

- 2 A horse-shoe dial aperture design represents a lucky charm  
 L'ouverture de cadran en forme de fers à cheval représente un porte-bonheur  
 Eine in Hufeisenform gestaltete Öffnung präsentiert sich als Glücksbringer  
 La esfera tiene una apertura en forma de herradura que es un amuleto de la suerte  
 ダイヤル開口部の幸運を意味する馬蹄のデザイン  
 錶盤馬蹄形鏤空設計象徵著幸運符  
 Окно на циферблате имеет форму подковы, которая является символом удачи  
 فتحة عداد على شكل حذوة حصان جلب الحظ









85025 3M BUIN















10220 357RM AR







- QUARTZ
- PVD
- 5 ATM
- 17mm
- 7.1mm
- 66g

2-HANDS  
57002 37RM AIR Ø 29 MM



- QUARTZ
- PVD
- 5 ATM
- 17mm
- 7.1mm
- 66g

2-HANDS  
57002 37RM AR Ø 29 MM



- QUARTZ
- PVD
- 5 ATM
- 17mm
- 7.1mm
- 66g

2-HANDS  
57002 37RM BRIR Ø 29 MM



- QUARTZ
- PVD
- 5 ATM
- 17mm
- 7.1mm
- 30g

2-HANDS  
57002 37RC AIR Ø 29 MM



- QUARTZ
- PVD
- 5 ATM
- 17mm
- 7.1mm
- 30g

2-HANDS  
57002 37RC AR Ø 29 MM



- QUARTZ
- PVD
- 5 ATM
- 17mm
- 7.1mm
- 30g

2-HANDS  
57002 37RC BRIR Ø 29 MM









57002 3M ROIN





A wide-angle photograph of a winter landscape. The foreground is filled with a dense forest of evergreen trees, their branches heavily laden with snow. The middle ground shows a valley with snow-covered fields and scattered trees, leading to a range of low mountains in the distance. The sky is a pale, clear blue, suggesting a bright but cold day. The overall scene is serene and captures the beauty of a winter mountain setting.

Farmers in summer working the soil in the fields or breeding their cattle, our predecessors began working as watchmakers during the harsh winter months in order to make some money to sustain during the coldest period of the year.

Getting more and more professional and developing their skills, the former farmers slowly became highly skilled watchmakers.

# LES BÉMONTS

STYLE & ELEGANCE



LES  
BÉMONTS



1 Stunning view on the movement thanks to dial aperture  
 Ouverture de cadran offrant une vue magnifique sur le mouvement  
 Die Zifferblattöffnung gibt den Blick frei auf das beeindruckende Uhrwerk  
 Impresionante visión del movimiento gracias a la apertura de la esfera  
 ダイアル開口部から鑑賞できるムーブメントの美しい眺め  
 令人驚豔的沙漏鏤空錶面  
 Потрясающий вид на механизм благодаря окну на циферблате

مشهد رائع للحركة بفضل فتحة العداد

2 Classical, elegant and timeless design, with wide dial openings and pure case lines

Design classique, élégant et intemporel avec de larges ouvertures de cadran et des lignes de boîtier pures

Klassisches, elegantes und zeitloses Design mit grossen Zifferblattöffnungen und klaren Gehäusekonturen

Diseño clásico, elegante e intemporal, con grandes aperturas en la esfera y caja de líneas puras

クラシカルでエレガント、時代に左右されないデザインと、大きな開口部を持つダイアルデザインとシンプルなケースライン

經典、優雅、和永恆的設計，搭配拱弧線錶殼

Классический, элегантный и нестареющий дизайн, с широкими окнами на циферблате и чистыми линиями корпуса

تصميم كلاسيكي خالد مع فتحات عداد واسعة وخطوط علبة نقية



85300 37R GIR Ø 42 MM

3 Transparent caseback offering view on the beating heart of the watch  
 Dos de boîtier transparent permettant d'observer le « cœur » en mouvement de la montre

Dank des durchsichtigen Gehäusebodens wird das schlagende Herz der Uhr sichtbar

Tapa de reloj transparente que permite ver los latidos del corazón del reloj

時計が刻む鼓動が観賞できるシースルーケースバック

鏤空後底蓋可欣賞機芯的運轉

Прозрачная задняя крышка открывает вид на бьющееся сердце часов

غطاء خلفي شفاف يمكن من مشاهدة قلب الساعة التابع



22mm

10.8mm

102g

LES BÉMONTS C.R.-F.  
LIMITED EDITION  
95005 3 AIR Ø 44 MM  
LIMITED EDITION OF 200 PIECES WORLDWIDE



C.R.-F.

Official Certificate

LES BÉMONTS C.R.-F.  
LIMITED EDITION

C.R.-F.

EDOX  
Maison Fondateur - Les Bémonts  
depuis 1862

...the movement automatic  
chronograph movement.  
The fasteners are  
brass, engraved  
of an engraving the  
founder's watch, the  
and the setting of time  
can be moved by the crown  
without the need of  
any tools.

...with black leather strap perfectly  
completing a watch of classic  
elegance.

The case back of the watch is  
engraved with the name of the  
founder and the date of the  
founding of the brand.

The Les Bémonts C.R.-F. Limited Edition  
is a watch that is both elegant and  
technical. It is a watch that is  
both a work of art and a technical  
achievement.

The watch is made in Switzerland  
and is a true masterpiece of  
Swiss watchmaking.

The watch is a limited edition  
of 200 pieces and is a true  
collector's item.

The watch is a true masterpiece  
of Swiss watchmaking and is a  
true collector's item.





























OPEN HEART  
85021 3 NIN Ø 42 MM



OPEN HEART  
85021 3 BUIN Ø 42 MM



OPEN HEART  
85021 3 AIN Ø 42 MM







CHRONOGRAPH MOON PHASE **NEW**  
01651 37R BUIR Ø 42 MM



CHRONOGRAPH MOON PHASE **NEW**  
01651 37R AR Ø 42 MM



CHRONOGRAPH MOON PHASE **NEW**  
01651 37R AIR Ø 42 MM



CHRONOGRAPH MOON PHASE **NEW**  
01651 37J AR Ø 42 MM



CHRONOGRAPH MOON PHASE **NEW**  
01651 37J AID Ø 42 MM





-  QUARTZ
-  DAY DATE
- 
-  ST STEEL
-  PVD
-  3 ATM
-  22mm
-  7.9mm
-  74g

**MOON PHASE COMPLICATION NEW**  
40002 37R BUIR Ø 42 MM



-  QUARTZ
-  DAY DATE
- 
-  ST STEEL
-  PVD
-  3 ATM
-  22mm
-  7.9mm
-  74g

**MOON PHASE COMPLICATION NEW**  
40002 37R AR Ø 42 MM



- 
-  QUARTZ
-  DAY DATE
- 
-  ST STEEL
-  PVD
-  3 ATM
-  22mm
-  7.9mm
-  74g

**MOON PHASE COMPLICATION NEW**  
40002 37R AIR Ø 42 MM



-  QUARTZ
-  DAY DATE
- 
-  ST STEEL
-  PVD
-  3 ATM
-  22mm
-  7.9mm
-  74g

**MOON PHASE COMPLICATION NEW**  
40002 37J AR Ø 42 MM



-  QUARTZ
-  DAY DATE
- 
-  ST STEEL
-  PVD
-  3 ATM
-  22mm
-  7.9mm
-  74g

**MOON PHASE COMPLICATION NEW**  
40002 37J AID Ø 42 MM









Very classical and elegant, the caseback of Les Bémons stands for respecting the collection design.











New Edox factory in Les Genevez, Switzerland – Winter 2017





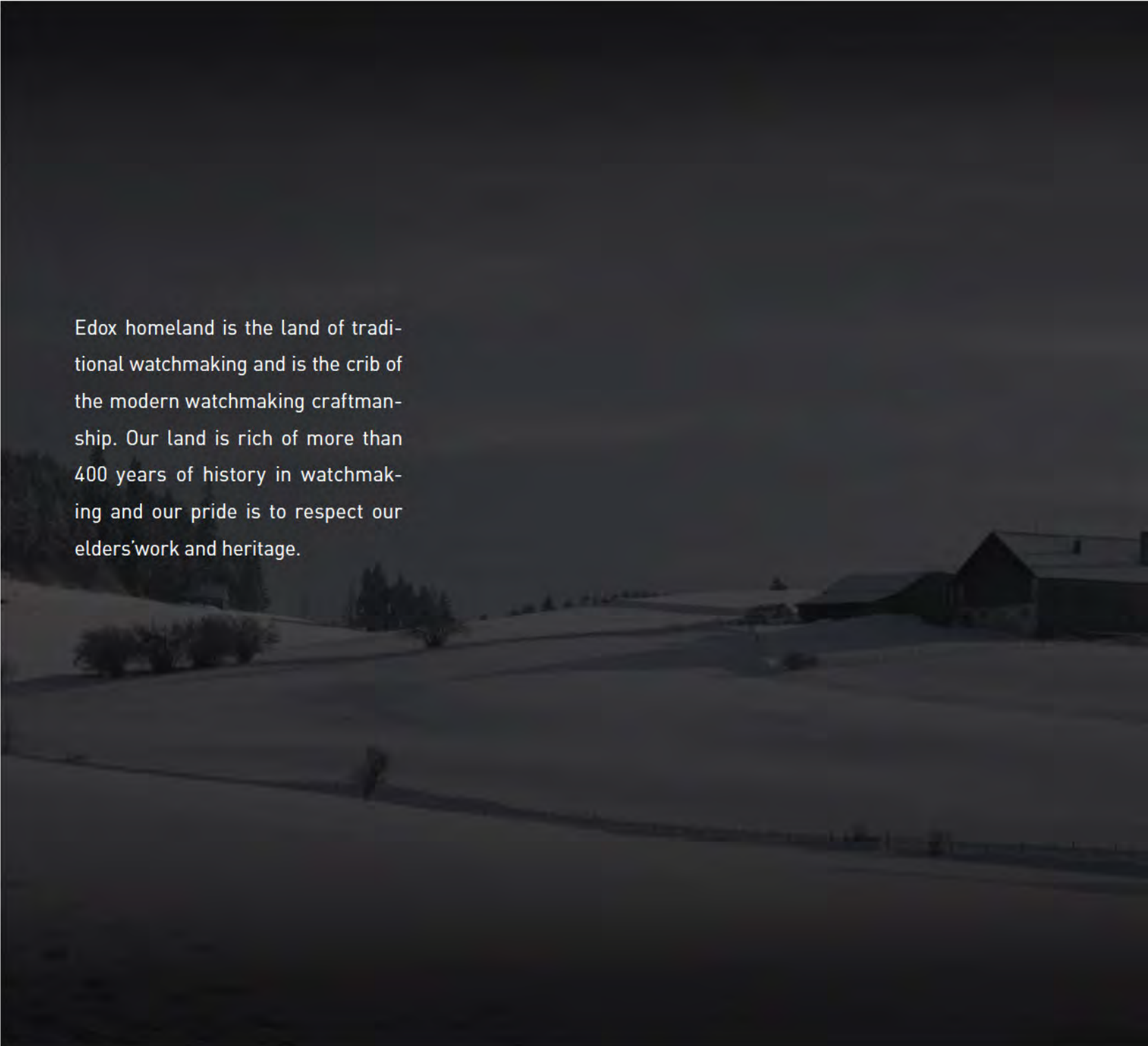

A dark, monochromatic photograph of a snowy landscape. The foreground is a vast, flat expanse of snow. In the middle ground, there are some small, dark bushes and a few trees. In the background, a large, dark barn or house is visible, partially obscured by the snow. The sky is a uniform dark grey, suggesting an overcast day. The overall mood is quiet and serene.

Edox homeland is the land of traditional watchmaking and is the crib of the modern watchmaking craftsmanship. Our land is rich of more than 400 years of history in watchmaking and our pride is to respect our elders' work and heritage.

# LES VAUBERTS

TRADITION OF 4 CENTURIES



LES  
VAUBERTS



1 Stunning view on the movement thanks to dial aperture  
 Ouverture de cadran offrant une vue magnifique sur le mouvement  
 Die Zifferblattöffnung gibt den Blick frei auf das beeindruckende Uhrwerk  
 Impresionante visión del movimiento gracias a la apertura de la esfera  
 ダイヤル開口部から鑑賞できるムーブメントの美しい眺め  
 令人驚豔的扇型鏤空錶面  
 Потрясающий вид на механизм благодаря окну на циферблате

مشهد رائع للحركة بفضل فتحة العداد



85014 37R AIR Ø 43 MM

Pays tribute to EDOX watchmakers predecessors  
 Rend hommage aux horlogers EDOX qui nous ont précédés  
 Eine Hommage an die Vorgänger der Uhrmacher von EDOX  
 Rinde homenaje a los anteriores relojeros EDOX  
 エドックスの時計職人の先人達に敬意を表しています。  
 向 EDOX 的製錶前輩們致敬  
 Воздаёт должное часовщикам-предшественникам Edox  
 تكريم الساعتي EDOX السابقين

2 Caseback showing a typical farm where our elders manufactured clocks during the harsh winter months  
 Gravage sur le fond d'une ferme typique du Jura Suisse  
 Auf dem Gehäuseboden ist ein typischer Bauernhof, in der unsere Vorgänger früher während der kalten Wintermonate Uhren herstellten  
 Granja típica en la tapa, con el taller en el que nuestros antepasados fabricaban relojes durante los duros meses de invierno  
 先人達が厳しい冬の間、時計作りをする部屋のある典型的な農家が刻印が施されたケースバック  
 後底蓋鏤刻一個典型的農舍，前輩們在嚴冬季節製造鐘錶的鐘錶工作室  
 Задняя крышка показывает типичную ферму с комнатой для создания часов, где наши предки производили часы во время суровых зимних месяцев

غطاء خلفي نقشت عليه صورة مزرعة تمثل المكان حيث كان ساعاتيوننا السابقون يصنعون الساعات خلال شهور الشتاء القاسية



Rich of more than 4 centuries in watchmaking, the caseback engraving pays tribute to our predecessors who became skilled watchmakers during the harsh winter months of farming.









MARKETING & MORE





## COMPANY PRESENTATION

### Vision

Edox is steadily becoming one of the three most successful Swiss watch brands in the high-volume price segment of 400-4,000 Euros. Edox intends to set the standard when it comes to design, price and quality within this price range.

### Positioning in relation to the competition

Edox distinguishes itself from other brands thanks to its clearly segmented collection. None of its competitors' ranges (Tag Heuer, Longines, Baume & Mercier, Raymond Weil) in the middle price bracket offer such customer-oriented coverage of the various market segments (see target groups). Edox stockists can address four lucrative segments and thus enjoy a real advantage.

### Positioning

Edox is building a lasting reputation in the field of sports timing as the "Timekeeper for Championships". Edox is an autonomous and independent Swiss watch brand that is predominantly sports-oriented in the middle to upper price segment. It offers a full range of high-profile designs aimed at a young clientele with strong purchasing power and an eye for quality.

### The communications strategy

The concept is based on the sentence "Timing For Champions". The implementation of this strategy focuses on the presence to exclusive international events such as the logo presence on Formula One racing cars of the Sauber F1® Team. These events are broadcasted throughout the year on hundreds of international TV channels and this means that million of people see the Edox logo on the racing cars. This presence raises Edox's profile significantly and anchors viewers' awareness of the brand.

Country-specific communication projects rely on high-circulation print, electronic lifestyle or special interest publication and social media activities. These are boosted by Edox partnership with Sauber F1® Team.

### The Edox watch

An Edox watch stirs your emotions. Its design is distinctive and its sophisticated technology based on proven, established and dependable mechanics and electronics. Edox watches in this price category offer exceptional quality, captivating Edox owners around the world and impressing international watch connoisseurs.



### The product strategy

Edox watches carry the prestigious Swiss Made logo, an important and legally protected trademark attesting to the quality of luxury watches. Since 1884, Edox watches have been hand-produced by skilled watchmakers with a reputation for precision work in the Swiss Jura, a region that is globally renowned for its watchmaking prestige. The collection is aimed at four precisely defined target groups (see description of target groups).

## FRIENDS AND PARTNERSHIPS



### Sauber Motorsport

In 1970 Peter Sauber founded his company and designed his first racing car in the cellar of his parents' house. The race team grew steadily and enjoyed its first major international successes in the late 1980s. As the Mercedes works team, Sauber celebrated a one-two victory in the Le Mans 24-hour race in 1989 and back-to-back Drivers' and Manufacturers' titles in the World Sports Car Championship in 1989 and 1990. In 1993 Sauber entered Formula One. Among the team's F1 highlights have been a fourth-place finish in the Constructors' World Championship in 2001 as an independent team and – in partnership with BMW – a one-two finish in the 2008 Canadian Grand Prix on the way to third place in the constructors' standings that year. In 2010 Sauber became an independent outfit once again. 2012 was a very good year of the **Sauber F1® Team**, headlined by four podium finishes, 126 World Championship points and sixth place in the constructors' standings. The 11th October 2012 marked a milestone in the history of the team – the day when Sauber stepped down as Team Principal and passed on the baton to Monisha Kaltenborn. Between 1993 and the end of 2015 the team contested 403 grands prix in Formula One. Sauber has its headquarters in Hinwil, in the Swiss canton of Zurich. The team's state of the art factory houses manufacturing facilities and offices spanning an area of 15,600 square meters and boasts one of the most advanced wind tunnels in F1.

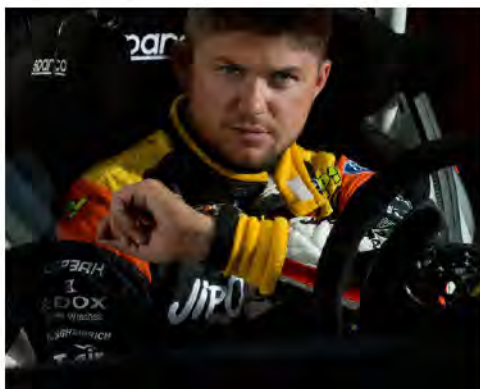

### Martin Prokop

Martin Prokop was born in Jihlava 1982. Since childhood he was dreaming to become a rally driver. In 2001 this dream came true and Martin made his first debut on Rally Vysocina with Skoda Felicia.

In Monte Carlo 2005 Martin started t in the Junior World Championship with Citroen C1S1600. One year later he celebrated the victory on Catalunya Rally. The most successful season was 2009 when Martin won the Junior World Champion title.

In Argentina 2012 Martin made a new record for Czech crew and reached the 4th place with his co-driver Zdeněk Hrůza. One year later he repeated it in Germany and this year again Argentina.



photo: XCAT world series

### Pal Virik Nilsen

Pal Virik Nilsen from Sandefjord, Norway is one of the most experienced and best powerboat pilots in the world. His career the last 22 years with over 270 races, has been filled with almost all classes and type of boats the international federation (UIM) can offer in the sport of powerboating.

Virik Nilsen is a former World Champion, three times Australian Class-1 champion, and two times Norwegian Champion. All in all he has six UIM international medals from European and World Championships both categories Offshore and Circuit racing.

During his career Pål has been driving for some of the best teams in the world such as "Spirit of Norway" "Victory team UAE" and Maritimo Australia among others. Pål is probably the most fit driver in the sport with training every day all year long. With the goal to be maximum prepared mentally and physically before and during every Powerboat season.

In 2009 he was awarded the Motorsport personality of the year in Norway. A prestigious award that covers all motorsport categories available in Norway!

Pål is also a member of the international athletes committee in the federation. In Norway he is currently the leader of circuit federation group and vice president in the powerboat section.

A truly passionate powerboat pilot and ambassador!



**Christian Redl – The Iceman**

Born in 1976, the Austrian Christian Redl fell in love with water as a young boy.

But 1996 was a major turning point for him when he saw the cult film *The Big Blue* and took up free-diving. At a championship meeting the same year, he met the famous free-diver, Umberto Pelizzari. A vocation was born.

This true merman, who tests the limits of the endurable, is considered to be one of the foremost free-diving specialists of his generation.

Christian Redl also holds several world free-diving records: the most impressive probably being the longest ever swim under ice (100 meters), though the crossing of several underwater caves in Mexico cannot be ignored. Christian Redl holds the record for the deepest free dive under ice to a depth of 60 meters, but has also been to the North Pole in April 2015 for a first world free dive under the ice.



**Curling Team Ulsrud**

Team Ulsrud is Norway's national curling team. Haavard Vad Petersson, Christoffer Svae, Torger Nergaard and Thomas Ulsrud started playing together in 2007. Among their many international achievements, their proudest moment as a team was winning the silver medal at the 2010 Olympic Winter Games in Vancouver.

## VISUAL ADVERTISING WINNERS

### Advertising Corporate Guidelines

For Edox, visual identity is highly important. Our "Timing For Champions" campaign has been developed to give more importance to the product.

The Edox Corporate Guidelines are set in order to ensure you that the artwork that you are preparing perfectly matches with the advertising layout instructions.

It also ensures perfect watch visibility with appropriate watch and logo sizes and all layout components.

### Advertising

Thank you for helping us in keeping the Edox brand image identical worldwide.

We remind you that all individually-designed layouts have to be submitted to Edox for final approval before printing of production.

All layouts are suitable for advertising, but also for banners, posters, window stickers, lightboxes, etc.



Format A4



All layouts are available on the Edoxnet database ([www.edox.ch/edoxnet](http://www.edox.ch/edoxnet))

For specific project, please contact Edox for full support.

Format A4 double page spread



GRAND OCEAN 88002 30RCA ABUN



GRAND OCEAN 01123 3BUCA NBUN



CO-1 10221 37R NIR



CO-1 01122 3 NIN



CHRONORALLY 10302 37N NIN



CHRONORALLY 38001 TIN NIN



CHRONORALLY 38001 TINN1 NBUI1



CHRONORALLY 10302 3 NIN2



CHRONORALLY -1 10305 3N VNV



DELFIN 10109 357NCA NIN



DELFIN 10109 357RNCA NIRG



DELFIN 85024 3M NIN

MARKETING & MORE VISUAL ADVERTISING WINNERS



LAPASSION 10220 357RM AIR



LAPASSION 85025 357RM AIR



LES BÉMONTS 85021 3 BUIN



LES BÉMONTS 85021 37R AIR





LES VAUBERTS 85014 37R GIR



# SOCIAL MEDIA

Facebook @Edox Swiss Watches 

Twitter @EdoxWatches 

Instagram @edoxswisswatches 

Youtube @EdoxWatches 

Pinterest @Edoxwatches 



## THE 7 COMPETENCES OF EDOX

Assembled by master watch makers, engineered for champions: for more than 130 years, Edox watches have combined ultimate precision with ingenious solutions – even for the most demanding activities: be it above or below the water surface, in the eternal ice or even on glowing desert sand, any timing instrument from Edox carrying the legendary hourglass logo will meet even the highest demands of its owner. One of the reasons and at the same time one of Edox strength lies in the construction and build quality of our

watch cases: from additional case-backs, ultra-complex cases to patented crown seals and guards, Edox has truly mastered the art of bringing together function and design. Or in other words: engineering a watch case consisting of up to 20 single components is probably the best proof of how serious we are when it comes to accomplishing perfection in every detail. Which means that as an owner of an Edox you will ultimately benefit from more robustness, quality and increased comfort.



### 1 IN-HOUSE DESIGN

Located in the heart of the Swiss Jura, Edox has been working for years with the same proven team when it comes to designing watches that are equally unique as perfect for their intended use:

- ☑ Instead of a computer-generated design, each watch is first hand drawn for a more organic look
- ☑ Exclusive made-to-measure and customised components when it comes to straps, dials and hands



### 2 ULTRA-COMPLEX CASES

Edox timing instruments are made for performance. Perfect example: Our complex cases usually consisting of more than just the standard three parts:

- ☑ Expert in complex case design and engineering
- ☑ Multipart construction with highest precision and attention to detail



### 3 RELIABLE WATCH MOVEMENTS

We believe in proven movements from the most reputable specialists. Because we want to make absolutely sure that you can rely on your watch every single second of a day – for years to come. In short:

- ☑ Proven Swiss Made calibres from leading movement suppliers
- ☑ World-wide service, reliability and access to spare parts



### 4 ULTIMATE PRECISION

When it comes to precision we are convinced that being as strict and meticulous as possible is well worth it. Because you will appreciate the quality and attention to detail:

- ☑ The manufacturing tolerance is 1/100 millimetre
- ☑ No standard components are used

**SAVOIR-FAIRE**

Our understanding of quality is one of the reasons we are successful



**5 SWISS HANDMADE MASTERPIECES**

Every single part of an Edox watch is made to exact specifications with the lowest possible fabrication tolerances. Nevertheless: Assembly and regulation are still done by hand by skilled watchmakers in Les Genevez, Switzerland.

- ☑ One watchmaker is responsible for the whole watch during assembly and regulation
- ☑ Production and quality control are strictly separated



**6 TIME FOR INNOVATION**

Edox has a long tradition of finding smart solutions for complex challenges, such as:

- ☑ World's first combined display in a world timer
- ☑ World-record holder for an ultra-flat movement featuring a calendar display
- ☑ Patented double sealed crown (without requiring a screw-in construction) for increased water resistance



**7 MADE FOR CHAMPIONS**

Edox has been chosen as official timekeeper of various competitions and races around the globe. Many athletes and explorers have relied on the quality of the Edox watches.

- ☑ Premium Partner of prestigious Formula One Swiss team: Sauber F1® Team.



POS MATERIAL



## DISPLAYS



- 1111 Edox Big Display  
(W 95 x D 47 x H 60,2 cm)
- ☑ 44 C-rings
  - ☑ 1 Base
  - ☑ 2 Sides
  - ☑ 4 Tobogans
  - ☑ 6 Watch Stands
  - ☑ 10 Product Plates



- 1112 Edox Medium Display  
 (W 60 x D 47 x H 49,2 cm)  
 30 C-rings  
 1 Base  
 4 Tobogans  
 3 Watch Stands  
 10 Product Plates



- 1114 Edox Small Display  
 (W 34 x D 35 x H 33,2 cm)  
 9 C-rings  
 1 Base  
 2 Tobogans  
 3 Watch Stands  
 10 Product Plates





- 1122 EDOX Incase Display  
 (W 83 x D 38 x H 8.2 cm)  
 22 C-rings  
 1 Base  
 2 Tobogans  
 2 Watch Stands 3cm  
 2 Watch Stands 4.5cm  
 10 Product Plates



- 1113 EDOX Incase Display Large  
 (W 124 x D 38 x H 8.2 cm)  
 36 C-rings  
 1 Base  
 2 Tobogans  
 3 Watch Stands 3cm  
 3 Watch Stands 4.5cm  
 10 Product Plates





## SHOP IN SHOP

All item finishes may be finalized,  
please contact us accordingly.



1124 EDOX Counter, including display material  
(W 141 x D 50 x H 120 cm)



1125 EDOX Wall  
(W 180 x D 50 x H 240 cm)



1123 EDOX Free Standing Show Cabinet, including  
display material  
(W 50 x D 50 x H 160 cm)

## DISPLAY ACCESSORIES



1115 EDOX Watch Stand  
Set of 3 pieces  
4, 6 and 8 cm height



1064 Edox C-Clips  
(Set of 15 pcs)  
 10 Gents: 7pcs vertical-3pcs horizontal  
 5 Ladies: 3pcs vertical-2pcs horizontal  
Suitable only for displays 1047, 1048, 1049, 1086  
and 4062



1090 LCD Display  
(W 12.5 x D 2.5 x H 9.5 cm)  
Plug and Play function



1117 Edox Tobogan  
29 x 4 cm



1116 Edox Presentation Tray  
35 x 32 cm



1120 Edox 10 C-Clips Set for the new Edox  
Display Programme (Display red. 1111,  
1112, 1114, 1122)

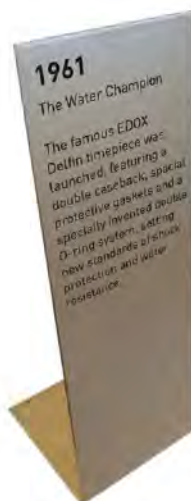

1119 Edox Product Plate  
(set of 6 plates, various languages available)



1118 Edox Retailer Plate  
W 10 x D 2.2 x H 10 cm

## PACKAGING - CATALOGUES - CERTIFICATES



New Packaging for all collections  
with instruction manual and warranty card



1088 After Sale Service and Duty Free  
Programme Watch Box



1109 Edox shopping bag



4040 Edox Booklet Holder  
(W 15 x D13.5 x H 12 cm)



1110 Selyt



4059 Edox Black Gloves



0034 Edoxionary for watch professionals

## WALL CLOCK - GIVE-AWAYS



1045 Edox wall clock  
Grand Ocean Wall Clock -  
Diameter 45cm



1130 Sauber Cap



1107 Edox Cap



1055 Edox USB Key



1103 Executive Wheeled Carry-on Bag



1108 Lanyard





## TECHNICAL INFORMATION

**EDOX QUALITY**

**CLASP & BUCKLE**

**MOVEMENTS**

**REFERENCE NUMBER SYSTEM**

**PICTOGRAMS**



## EDOX QUALITY

### Batteries

In compliance with global regulations and standards, Edox equips its quartz timepieces with mercury-free batteries. This is a positive step towards environmental sustainability with no effect on the watch precision and efficiency.

### Bronze

A fascinating material often associated with the sea. Bronze is highly resistant to the corrosive action of salted water and atmospheric components. It preserves its warm original tones, while acquiring a superb worn look, thanks to the patina which forms over time, making every watch unique.

### Conformity

Every component coming into our production facility in Les Genevez in the Swiss Jura is checked to ensure its dimensions, aesthetics, quality and interchangeability.

### Edox double O'ring Crown or Pusher

Since the 70's, Edox has set specific quality and technical standards for ensuring the water resistance of diving timepieces. The double O'ring crown or pusher has been engineered by Edox to allow to increase the resistance to water pressure. Timepieces equipped with crowns or pushers featuring a double O'ring are featuring the special pictogram for easy understanding.

### Helium Escape Valve

Some of our CO-1 timepieces are equipped with a decompression system which allows helium to escape from inside the watch when worn for professional use in pressure chambers (long-term underwater work, crude oil exploration, etc).

The Edox helium valve opens and closes automatically. It is imperative that the models equipped with a non-automatic helium escape valve (such as older Edox timepieces) have the helium valve screwed back in order to guarantee their water resistance.

### Leather

All Edox leather straps are specially cut, stitched and padded by expert craftspeople. Various ways of tanning provide different touch and feel for the straps made of cow or calf leather. It is always important to remember that colors and suppleness of leather are subject to change with time and exposure to external factors. Daily showers or swims are not recommended. If your consumers live a very active lifestyle, especially one involving frequent exposure to salt water and heavy perspiration, we recommend a steel bracelet or rubber strap.

### Luminescence

This technology, branded under the name Super-Luminova, offers brightness in low-light conditions, thanks to a non-radioactive and non-toxic material like the tritium previously employed in the industry. Edox uses Super-Luminova for its highly functional attributes. It is applied on watch parts such as hands, numerals, bezel indices, etc.

### Mother-of-pearl

Resilient, and iridescent, mother-of-pearl is integrated in many Edox dial designs. It is produced inside the shells of certain mollusk shells. This is why each dial made of mother-of-pearl is unique.

### Movements

**Mechanical movement:**  
A mechanical movement undergoes several stresses in its life. To ensure it will remain functional and precise as long as possible, Edox simulates watch wearing in its own quality office for every single manual and self-winding mechanism.

### PVD

Edox uses PVD coatings which is a high-performance pollution-free and non-allergenic technology also used in the aeronautic industry, is widely used in watchmaking. The process involves putting a fine titanium coating on stainless steel by condensing a metal vapor in a partial vacuum.

### Rubber

Edox uses genuine high-grade rubber for its straps (a natural material and extremely comfortable). The rubber is silky finished and easy to maintain with the proper cleaning.

### Sapphire crystals

100% of Edox timepieces are fitted with a scratch-resistant crystal that has been cut from a polished slice of solid sapphire. Each has a triple-coated anti-reflective treatment on the internal side for better legibility.

### Stainless Steel

The 316L stainless steel alloy used in Edox cases and bracelets has strong anti-magnetic properties and is optimized for toughness and corrosion resistance. It is also a good choice for consumers allergic to nickels.

### Titanium

Edox integrates this metal to some of its sports timepieces, as it is as strong as steel but 45% lighter and highly resistant to corrosion. The high tensile strength to density ratio makes it the ideal material for active lifestyles.

### Visual and manual testing

In addition to our testing process, all timepieces are visually checked between each manufacturing step ensuring overall quality based on our own Edox standards. If a timepiece does not pass inspection, it is checked and repaired. It can only go back to the production phase if it has passed the quality check.











Free Dive World Champion Christian Redl recommends the following Water Resistance:

 **Water-resistance**

Edox watch cases are hermetically sealed using high-grade rubber gaskets and screwed-in casebacks to ensure that no moisture or dust comes in contact with the movement inside.

### WATER RESISTANCE CLASSIFICATION

	Meters	Feet	ATM	All Edox timepieces are water-resistant from 30 to 1000 metres. Check the details on the back of your Edox timepiece and read the following instructions carefully.	Collection
	30	100	3	Will withstand rain or splashes of water and accidental immersion, but should not be worn while showering, swimming or diving.	Les Bémonts
	50	165	5	Suitable for showering or swimming in shallow water.	Les Vauberts, LaPassion
	100	330	10	Suitable for swimming or snorkelling.	Chronorally, Chronorally-S, Grand Ocean
	200	650	20	Suitable for swimming or snorkelling.	Delfin
	300	990	30	Suitable for scuba diving.	CO-1, Grand Ocean
	500	1650	50	Appropriate for serious deep water diving.	CO-1



## CLASP & BUCKLE

### GRAND OCEAN



<b>80077 3</b>	CHRONOMETER	page 15
<b>85008 3</b>	OPEN HEART AUTOMATIC	page 15



<b>85012 3</b>	OPEN VISION AUTOMATIC	page 18
<b>85012 357J</b>	OPEN VISION AUTOMATIC	page 18
<b>85012 357N</b>	OPEN VISION AUTOMATIC	page 18



<b>01121 357RN</b>	CHRONOGRAPH AUTOMATIC	page 12
--------------------	-----------------------	---------



<b>85301 357RN</b>	AUTOMATIC PHANTOM OF TIME	page 13
--------------------	---------------------------	---------



<b>85013 3</b>	OPEN VISION AUTOMATIC	page 17
<b>85013 357J</b>	OPEN VISION AUTOMATIC	page 17



<b>01123 357RCA</b>	CHRONOGRAPH AUTOMATIC	page 12
<b>01123 3...CA</b>	CHRONOGRAPH AUTOMATIC	page 12
<b>10226 3...CA</b>	CHRONOGRAPH	page 19
<b>10226 357...CA</b>	CHRONOGRAPH	page 19
<b>56002 3...C</b>	ULTRA SLIM	page 21
<b>56002 357RC</b>	ULTRA SLIM	page 21
<b>85301 3</b>	AUTOMATIC PHANTOM OF TIME	page 13
<b>88002 357RCA</b>	AUTOMATIC DAY DATE	page 14
<b>88002 3...CA</b>	AUTOMATIC DAY DATE	page 14



<b>85012 357JN</b>	OPEN VISION AUTOMATIC	page 18
--------------------	-----------------------	---------



<b>85301 37J</b>	AUTOMATIC PHANTOM OF TIME	page 13
------------------	---------------------------	---------

### CO-1



<b>01122 37R</b>	CHRONOGRAPH AUTOMATIC	page 27
<b>10221 37N</b>	CHRONOGRAPH	page 33
<b>10221 37R</b>	CHRONOGRAPH	page 33
<b>10221 37RBU7</b>	CHRONOGRAPH	page 29
<b>10225 37R</b>	CHRONOLADY	page 34
<b>10411 37N</b>	CHRONOLADY	page 35
<b>10411 37NR120D</b>	CHRONOLADY	page 35
<b>80099 3</b>	OFFSHORE-1 PROFESSIONAL	page 28
<b>80099 37R</b>	OFFSHORE-1 PROFESSIONAL	page 28



<b>01122 3</b>	CHRONOGRAPH AUTOMATIC	page 26
<b>10221 3BU7</b>	CHRONOGRAPH	page 29
<b>10221 3N</b>	CHRONOGRAPH	page 31
<b>10221 357R</b>	CHRONOGRAPH	page 31
<b>10221 3</b>	CHRONOGRAPH	page 31
<b>10225 3</b>	CHRONOLADY	page 34



<b>10225 37RB</b>	CHRONOLADY	page 34
-------------------	------------	---------

CO-1 continuation



<b>01122 3M</b>	CHRONOGRAPH AUTOMATIC	page 26
<b>10221 357RM</b>	CHRONOGRAPH	page 31
<b>10221 3M</b>	CHRONOGRAPH	page 31

CHRONORALLY



<b>10302 3M</b>	CHRONORALLY	page 46
<b>10302 3MV</b>	CHRONORALLY	page 46



<b>10302 3... / 37</b>	CHRONORALLY	pages 46, 48, 49
------------------------	-------------	------------------



<b>10302 37N</b>	CHRONORALLY	pages 48, 49
<b>38001 TIN</b>	CHRONORALLY	pages 40, 44

CHRONORALLY 1



<b>01118 3</b>	CHRONOGRAPH AUTOMATIC	page 54
<b>10305 3NR</b>	CHRONORALLY	page 55
<b>10305 3NV</b>	CHRONORALLY	page 55
<b>80094 3</b>	AUTOMATIC	page 54
<b>80094 3N</b>	AUTOMATIC	page 54



<b>01118 37NR</b>	CHRONOGRAPH AUTOMATIC	page 54
-------------------	-----------------------	---------



<b>10305 3NVM</b>	CHRONORALLY	page 55
-------------------	-------------	---------

**CHRONORALLY-S**



<b>10227 3M</b>	CHRONOGRAPH	page 60
<b>10227 3NBUM</b>	CHRONOGRAPH	page 60
<b>10229 3M</b>	CHRONOGRAPH	page 62
<b>10229 3NBUM</b>	CHRONOGRAPH	page 62
<b>84300 3M</b>	3-HANDS	page 64
<b>84300 3NBUM</b>	3-HANDS	page 64



<b>10227 3CA</b>	CHRONOGRAPH	page 61
<b>10227 3NBUCA</b>	CHRONOGRAPH	page 61
<b>10227 TINCA*</b>	CHRONOGRAPH	page 61
<b>10229 3CA</b>	CHRONOGRAPH	page 63
<b>84300 3CA</b>	3-HANDS	page 65
<b>84300 3NBUCA</b>	3-HANDS	page 65

\* [titanium buckle]



<b>10227 357RNCA</b>	CHRONOGRAPH	page 61
<b>10229 37RCA</b>	CHRONOGRAPH	page 63
<b>10229 357RNCA</b>	CHRONOGRAPH	page 63
<b>84300 37RCA</b>	3-HANDS	page 65

**DELFIN THE ORIGINAL**



<b>53005 37GRM</b>	3-HANDS	page 78
<b>54004 37GRM</b>	3-HANDS	page 79
<b>85024 37GRM</b>	OPEN HEART	page 74



<b>10108 3BU</b>	CHRONOGRAPH	page 75
<b>53005 3BUM</b>	3-HANDS	page 78
<b>53005 3M</b>	3-HANDS	page 78
<b>54004 3M</b>	3-HANDS	page 79
<b>54004 3BUM</b>	3-HANDS	page 79
<b>85024 3BUM</b>	OPEN HEART	page 72
<b>85024 3M</b>	OPEN HEART	page 72



<b>10109 3M</b>	CHRONOGRAPH	pages 74, 75
<b>10110 3M</b>	CHRONOGRAPH	page 77



<b>10109 357RBUM</b>	CHRONOGRAPH	page 74
----------------------	-------------	---------



<b>10109 357JVM</b>	CHRONOGRAPH	page 75
<b>10110 357JM</b>	CHRONOGRAPH	page 76

**DELFIN THE ORIGINAL** continuation

<b>10109 3CA</b>	CHRONOGRAPH	page 74
<b>10109 357GNCA</b>	CHRONOGRAPH	page 75
<b>10110 357RNCA</b>	CHRONOGRAPH	page 76



<b>10109 3CA</b>	CHRONOGRAPH	page 74
<b>10109 357NCA</b>	CHRONOGRAPH	page 74
<b>10110 3CA</b>	CHRONOGRAPH	page 77
<b>10110 357JCA</b>	CHRONOGRAPH	page 76
<b>10110 357RCA</b>	CHRONOGRAPH	page 76
<b>88004 BRZBU</b>	DELFIN FLEET 1650 LIMITED EDITION	page 71
<b>88004 3</b>	DELFIN FLEET 1650 LIMITED EDITION	page 71



<b>10109 357RNCA</b>	CHRONOGRAPH	page 74
----------------------	-------------	---------

**LAPASSION**

<b>10220 357RM</b>	CHRONOGRAPH	page 90
<b>10220 3M</b>	CHRONOGRAPH	pages 94, 95
<b>57002 357RM</b>	2-HANDS	page 96
<b>57002 3M</b>	2-HANDS	pages 100, 101
<b>85025 357RM</b>	OPEN HEART	page 84
<b>85025 3M</b>	OPEN HEART	pages 88, 89



<b>10220 3C</b>	CHRONOGRAPH	pages 94, 95
<b>57002 3C</b>	2-HANDS	pages 100, 101
<b>85025 3C</b>	OPEN HEART	pages 88, 89



<b>10220 37RM</b>	CHRONOGRAPH	pages 90, 91
<b>57002 37RM</b>	2-HANDS	pages 96, 97
<b>85025 37RM</b>	OPEN HEART	pages 84, 85



<b>10220 357RC</b>	CHRONOGRAPH	page 92
<b>10220 37RC</b>	CHRONOGRAPH	pages 90, 91
<b>57002 357RC</b>	2-HANDS	page 98
<b>57002 37RC</b>	2-HANDS	pages 96, 97
<b>85025 357RC</b>	OPEN HEART	page 86
<b>85025 37RC</b>	OPEN HEART	pages 84, 85

LES BÉMONTS



<b>01602 37J</b>	PERPETUAL CALENDAR	page 119
<b>01651 37J</b>	CHRONOGRAPH MOON PHASE	page 120
<b>10501 37J</b>	CHRONOGRAPH COMPLICATION	page 118
<b>40002 37J</b>	MOON PHASE COMPLICATION	page 122
<b>56001 37J</b>	SLIM LINE DATE	page 128
<b>57001 37J</b>	SLIM LINE DATE	page 128
<b>85300 37J</b>	AUTOMATIC SHADE OF TIME	page 113



<b>01120 3</b>	CHRONOGRAPH AUTOMATIC	page 109
<b>01602 3</b>	PERPETUAL CALENDAR	page 119
<b>01651 3</b>	CHRONOGRAPH MOON PHASE	page 121
<b>10501 3</b>	CHRONOGRAPH COMPLICATION	page 118
<b>40002 3</b>	MOON PHASE COMPLICATION	page 123
<b>56001 3</b>	SLIM LINE DATE	page 130
<b>57001 3</b>	SLIM LINE DATE	page 130
<b>64012 3</b>	BIG DATE SMALL SECOND	page 125
<b>83015 3</b>	DAY DATE	page 115
<b>85021 3</b>	OPEN HEART	page 117
<b>95005 3</b>	LES BÉMONTS C. R.-F. LIMITED EDITION	page 106
<b>85300 3</b>	AUTOMATIC SHADE OF TIME	page 113



<b>01120 37R</b>	CHRONOGRAPH AUTOMATIC	page 108
<b>01602 37R</b>	PERPETUAL CALENDAR	page 119
<b>01651 37R</b>	CHRONOGRAPH MOON PHASE	page 120
<b>10501 37R</b>	CHRONOGRAPH COMPLICATION	page 118
<b>40002 37R</b>	MOON PHASE COMPLICATION	page 122
<b>56001 37R</b>	SLIM LINE DATE	pages 127, 128
<b>57001 37R</b>	SLIM LINE DATE	pages 127, 128
<b>64012 37R</b>	BIG DATE SMALL SECOND	page 124
<b>83015 37R</b>	DAY DATE	page 114
<b>85021 37R</b>	OPEN HEART	page 116
<b>85300 37R</b>	AUTOMATIC SHADE OF TIME	page 113



<b>01120 37RM</b>	CHRONOGRAPH AUTOMATIC	page 108
<b>56001 37RM</b>	SLIM LINE DATE	page 126
<b>57001 37RM</b>	SLIM LINE DATE	page 126
<b>64012 37RM</b>	BIG DATE SMALL SECOND	page 124
<b>83015 37RM</b>	DAY DATE	page 114
<b>85021 37RM</b>	OPEN HEART	page 116



<b>01120 3M</b>	CHRONOGRAPH AUTOMATIC	page 109
-----------------	-----------------------	----------

LES VAUBERTS















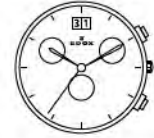

<b>85014 3</b>	OPEN HEART AUTOMATIC	page 136
<b>85019 3A</b>	OPEN HEART	page 137
<b>85019 3N</b>	OPEN HEART	page 137











<b>85014 37R</b>	OPEN HEART AUTOMATIC	page 136
<b>85019 37RA</b>	OPEN HEART	page 137
<b>85019 37RG</b>	OPEN HEART	page 137







## MECHANICAL MOVEMENTS

CALIBER / MANUFACTURER	07 SW 300 DUBOIS-DÉPRAZ 312	011 VALJOUX 7750	30 ETA 2892-2 DUBOIS-DÉPRAZ 285	45 ETA 2892-A2 DUBOIS DÉPRAZ 4500
MOVEMENT	 	 	 	 
FUNCTIONS	Display of hours, minutes, seconds and date. 24 time zone display	Display of hours, minutes, seconds and date. Chronograph. Day and Date	Display of hours, minutes, seconds, chronograph and date	Display of hours, minutes, seconds. Chronograph and Big Date
Frequency	28'800 A/h	28'800 A/h	28'800 A/h	28'800 A/h
Power reserve	40-44 h	46 h	42 h	40-44 h
Diameter	25.60 mm (1 1/2''')	30.00 mm (1 3/4''')	30.00 mm (1 3/4''')	30.00 mm (1 3/4''')
Movement height	4.85 mm	7.90 mm	6.50 mm	7.30 mm
Number of jewels	25 jewels	25 jewels	41 jewels	49 jewels
Shock resistance	Incabloc	Incabloc	Incabloc	Incabloc
Max. variation all positions	22 s/d	20 s/d	22 s/d	22 s/d

CALIBER / MANUFACTURER	72 ETA 7001	77 ETA 2892-A2 DUBOIS-DÉPRAZ 14070	80 ETA 2824 / SW 200	80 ETA 2892-A2
MOVEMENT	 	 	 	 
FUNCTIONS	Display of hours, minutes, and small second at 6 o'clock	Display of hours, minutes, seconds and date, regulator	Display of hours, minutes, seconds and date	Display of hours, minutes, seconds, date, COSC certified
Frequency	21'600 A/h	28'800 A/h	28'800 A/h	28'800 A/h
Power reserve	42 h	42 h	38 h	42 h
Diameter	23.30 mm (10 1/2''')	30.00 mm (1 3/4''')	25.60 mm (1 1/2''')	25.60 mm (1 1/2''')
Movement height	2.50 mm	5.20 mm	4.60 mm	3.60 mm
Number of jewels	17 jewels	25 jewels	25 jewels / 26 jewels	21 jewels
Shock resistance	Incabloc	Incabloc	Novodiac or Etachocs	Novodiac or Etachocs
Max. variation all positions	25 s/d	22 s/d	30 s/d	15 s/d

## MECHANICAL MOVEMENTS



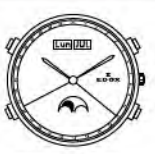





CALIBER / MANUFACTURER	802	SW 200	82	ETA 2004-1	83	ETA 2834 / SW 240	85	ETA 2824 / SW 200
MOVEMENT	 		 		 		 	
FUNCTIONS	Display of hours, minutes, seconds and date		Display of hours, minutes, seconds and date		Display of hours, minutes, seconds, day and date		Display of hours, minutes and seconds	
Frequency	28'800 A/h		28'800 A/h		28'800 A/h		28'800 A/h	
Power reserve	42 h		40 h		42 h		42 h	
Diameter	25.60 mm (1 1/2'')		23.30 mm (10 1/2'')		29.00 mm (1 13'')		25.60 mm (1 1/2'')	
Movement height	3.60 mm		3.60 mm		5.05 mm		4.60 mm	
Number of jewels	21 jewels		20 jewels		26 jewels		25 jewels	
Shock resistance	Incabloc		Incabloc		Incabloc or Etachocs		Novodiac	
Max. variation all positions	30 s/d*		30 s/d		30 s/d		30 s/d	





CALIBER / MANUFACTURER	853	SW200 (SEMI-SKELETONISED)	87	ETA 2892-A2 DUBOIS DÉPRAZ DK 87	88	SW 220-1	90	ETA 2824 SOPROD 9000
MOVEMENT	 		 		 		 	
FUNCTIONS	Display of hours, minutes and seconds		5 minute repeater Indication of time by the tone of 2 striking hammers		Display of hours, minutes, seconds, day and date		Display of hours, minutes, seconds. Day, date, month and moon phase	
Frequency	28'800 A/h		28'800 A/h		28'800 A/h		28'800 A/h	
Power reserve	42 h		42 h		38 h		38 h	
Diameter	25.60 mm (1 1/2'')		36.00 mm (1 6'')		25.6mm (1 1/2'')		25.60 mm (1 1/2'')	
Movement height	4.60 mm		7.35 mm		5.05 mm		6.20 mm	
Number of jewels	25 jewels		21 jewels		26 jewels		25 jewels	
Shock resistance	Novodiac		Incabloc		Incabloc		Incabloc	
Max. variation all positions	30 s/d		22 s/d		30 s/d		25 s/d	

\*For certified chronometer timepieces, the maximum variation per day is of +/- 3 seconds per day.







## MECHANICAL MOVEMENTS

CALIBER / MANUFACTURER	91	ETA 2824-2 / SW200 DUBOIS DÉPRAZ 291	92	VENUS 203	93	ETA 2893	94	ETA 2892-A2 SOPROD 9090
MOVEMENT	 		 		 		 	
FUNCTIONS	Display of hours, minutes, seconds, date and chronograph.		Display of hours, minutes, seconds, day, date, month and moon phase		Display of hours, minutes, seconds, second time zone (GMT)		Display of hours, minutes, seconds, power reserve and big date	
Frequency	28'800 A/h		18'000 A/h		28'800 A/h		28'800 A/h	
Power reserve	38 h		+/- 40 h		42 h		42 h	
Diameter	30.00 mm (1 1/4")		25.60 mm (1 1/2")		25.60 mm (1 1/2")		25.60 mm (1 1/2")	
Movement height	7.50 mm		5.25 mm		4.10 mm		5.10 mm	
Number of jewels	46 jewels		15 jewels		21 jewels		28 jewels	
Shock resistance	Incabloc		-		Incabloc		Incabloc	
Max. variation all positions	30 s/d		+1min/d		20 s/d		20 s/d	

CALIBER / MANUFACTURER	95	ETA 2894 52L	96	ETA 2895-2
MOVEMENT	 		 	
FUNCTIONS	Display of hours, minutes, seconds and chronograph.		Display of hours, minutes, small second	
Frequency	28'800 A/h		28'800 A/h	
Power reserve	42 h		42 h	
Diameter	28.00 mm (1 1/2")		25.60 mm (1 1/2")	
Movement height	6.10 mm		4.35 mm	
Number of jewels	37 jewels		27 jewels	
Shock resistance	Incabloc		Incabloc	
Max. variation all positions	30 s/d		20 s/d	

## QUARTZ MOVEMENTS

CALIBER / MANUFACTURER	26	EDOX CALIBRE 26000
MOVEMENT	 	
<b>The World's slimmest calendar movement</b>		
FUNCTIONS	Display of hours, minutes and date	
Diameter	19.95 mm (9'')	
Movement height	1.40 mm	
Battery	N° 341	

CALIBER / MANUFACTURER	27	EDOX CALIBRE 27000
MOVEMENT	 	
FUNCTIONS	Display of hours, minutes and date	
Diameter	23.30 mm (10 1/2'')	
Movement height	1.40 mm	
Battery	N° 341	

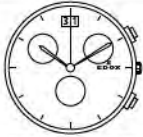
CALIBER / MANUFACTURER	10	RONDA 5040.B
MOVEMENT		
FUNCTIONS	Display of hours, minutes, seconds and big date, chronograph, split time	
Diameter	28.00 mm (12 1/2'')	
Movement height	4.40 mm	
Battery	N° 395	

CALIBER / MANUFACTURER	13N	ETA 251.272
MOVEMENT		
FUNCTIONS	Display of hours, minutes, seconds, date and chronograph.	
Diameter	30.00 mm (13 1/2'')	
Movement height	5.00 mm	
Battery	N° 394	

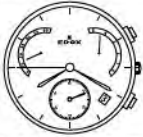
CALIBER / MANUFACTURER	015	ETA G15.261
MOVEMENT		
FUNCTIONS	Display of hours, minutes, seconds and date, chronograph retrograde	
Diameter	23.30 mm (10 1/2'')	
Movement height	5.25 mm	
Battery	N° 394	

CALIBER / MANUFACTURER	016	ETA G15.562
MOVEMENT		
FUNCTIONS	Display of days, minutes, small second, perpetual calendar, month, day and date retrograde	
Diameter	23.30 mm (10 1/2'')	
Movement height	5.25 mm	
Battery	N° 394	

CALIBER / MANUFACTURER	0165	ETA G10.962
MOVEMENT		
FUNCTIONS	Display of hours, minutes, seconds, chronograph, moon phase	
Diameter	31.75 mm (13 1/4'')	
Movement height	5.12 mm	
Battery	N° 394	

CALIBER / MANUFACTURER	34	RONDA 7004
MOVEMENT		
FUNCTIONS	Display of hours, minutes, small second, date retrograde.	
Diameter	33.80 mm (15'')	
Movement height	5.60 mm	
Battery	N° 381	

CALIBER / MANUFACTURER	38	RONDA 8040.N
MOVEMENT		
FUNCTIONS	Display of hours, minutes, day date, chronograph.	
Diameter	33.80 mm (15'')	
Movement height	5.60 mm	
Battery	N° 395	

CALIBER / MANUFACTURER	40	RONDA 706.1
MOVEMENT		
FUNCTIONS	Display of hours, minutes, seconds, date and moon phase	
Diameter	23.90 mm (10 1/2'')	
Movement height	3.00 mm	
Battery	N° 371	

## QUARTZ MOVEMENTS

CALIBER / MANUFACTURER	53	RONDA 515
MOVEMENT		
FUNCTIONS	Display of hours, minutes, seconds and date	
Diameter	26.20 mm (11 1/2'')	
Movement height	3.00 mm	
Battery	N° 371	

CALIBER / MANUFACTURER	54	RONDA 585
MOVEMENT		
FUNCTIONS	Display of hours, minutes, seconds and date	
Diameter	20.00 mm	
Movement height	3.00 mm	
Battery	N° 362	

CALIBER / MANUFACTURER	102	RONDA 5030.D
MOVEMENT		
FUNCTIONS	Display of hours, minutes, seconds, date and chronograph	
Diameter	28.00 mm (12 1/2'')	
Movement height	4.40 mm	
Battery	N° 395	

CALIBER / MANUFACTURER	103	RONDA 5021.D
MOVEMENT		
FUNCTIONS	Display of hours, minutes, seconds, date and chronograph	
Diameter	28.00 mm (12 1/2'')	
Movement height	4.40 mm	
Battery	N° 395	

CALIBER / MANUFACTURER	104	RONDA 5040.D
MOVEMENT		
FUNCTIONS	Display of hours, minutes, seconds, date, chronograph	
Diameter	28.00 mm (12 1/2'')	
Movement height	4.40 mm	
Battery	N° 395	

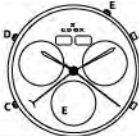
CALIBER / MANUFACTURER	105	RONDA 5040.F
MOVEMENT		
FUNCTIONS	Display of hours, minutes, seconds, day, date, month, chronograph	
Diameter	28.00 mm (12 1/2'')	
Movement height	5.40 mm	
Battery	N° 395	

CALIBER / MANUFACTURER	56	RONDA 714
MOVEMENT		
FUNCTIONS	Display of hours, minutes and date	
Diameter	19.95 mm (9'')	
Movement height	1.40 mm	
Battery	N° 341	

CALIBER / MANUFACTURER	57	RONDA 784
MOVEMENT		
FUNCTIONS	Display of hours, minutes and date	
Diameter	23.30 mm (10 1/2'')	
Movement height	1.40 mm	
Battery	N° 341	

CALIBER / MANUFACTURER	64	RONDA 6004B
MOVEMENT		
FUNCTIONS	Display of hours, minutes, small seconds and big date.	
Diameter	25.60 mm (11 1/2'')	
Movement height	3.30 mm	
Battery	N° 371	

CALIBER / MANUFACTURER	101	RONDA 5021.D
MOVEMENT		
FUNCTIONS	Display of hours, minutes, seconds, date and chronograph	
Diameter	28.00 mm (12 1/2'')	
Movement height	4.40 mm	
Battery	N° 395	



## REFERENCE NUMBER SYSTEM

The following information will help you on how to handle the Edox reference number, which will give you helpful product information regarding movements, dials and cases.

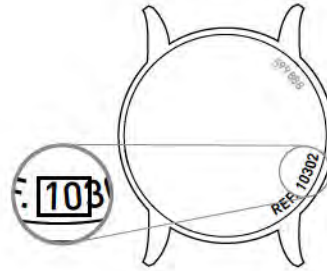

MOVEMENT	
<b>10</b>	please refer to the page 48
CASE MATERIAL	
3 / 3A / 3B / 3N	Stainless steel 316L
3BUO	Stainless steel 316L with blue and orange bezel
357A / 357J	Stainless steel 316L with yellow PVD coating
357BR	Stainless steel 316L with brown PVD coating
357B	Stainless steel 316L with blue PVD coating
357BU	Stainless steel 316L with blue PVD coating
357BRR	Brown and pink PVD coating
357JBUCA	Stainless steel 316L with pink PVD coating / Blue bezel, with rubber strap
357RC	Pink PVD coating on leather strap
357RM	Pink PVD coating on steel bracelet
357N	Stainless steel 316L with black PVD coating
357R	Stainless steel 316L with pink PVD coating
357RCA	Stainless steel 316L with pink PVD coating with rubber strap
357RD	Stainless steel 316L with pink PVD coating, diamonds
357RN	Pink and black PVD coating
3BU	Stainless steel 316L with blue bezel
3BUCA	Stainless steel 316L / Blue bezel with rubber strap
3BUM	Stainless steel 316L with blue bezel on steel bracelet
3C	Stainless steel 316L on leather strap
3CA	Stainless steel 316L on rubber strap
3M	Stainless steel 316L with steel bracelet
3NBU	Stainless steel 316L, black and blue bezel
3NCA	Stainless steel 316L, black bezel, with rubber strap
3NGCA	Stainless steel 316L, black and grey bezel, with rubber strap
3NGM	Stainless steel 316L, black and grey bezel, with steel bracelet
3NM	Stainless steel 316L, black bezel, with steel bracelet
3NOCA	Stainless steel 316L, black and orange bezel, with rubber strap
3NQM	Stainless steel 316L, black and orange bezel, with steel bracelet
3OCA	Stainless steel 316L, orange bezel, with rubber strap
3OM	Stainless steel 316L, orange bezel, with steel bracelet
3OR	Stainless steel 316L, orange bezel
3ORC	Stainless steel 316L with leather strap
3ORCA	Stainless steel 316L / Orange bezel with rubber strap
3NRCA	Stainless steel 316L, black and red bezel, with rubber strap
3NRM	Stainless steel 316L, black and red bezel, with steel bracelet
3NVCA	Stainless steel 316L, black and green bezel, with rubber strap
3NVM	Stainless steel 316L, black and green bezel, with steel bracelet
3PBU	Stainless steel 316L, blue pusher
3PR	Stainless steel 316L, red pusher
3V2	Stainless steel 316L, green pusher
37GR	Stainless steel 316L, grey and pink bezel
37GRM	Stainless steel 316L, grey and pink bezel, with steel bracelet
37J	Yellow PVD coating
37JC	Yellow PVD coating / with leather strap
37JA	Yellow PVD coating, silver ring
37JG	Yellow PVD coating, golden ring
<b>37N</b>	Black PVD coating
37NJ	Black PVD coating, golden pusher
37NPN	Black PVD coating, black pusher
37R	Pink PVD coating
37RBU	Pink PVD coating, blue bezel
37RC	Pink PVD coating, with leather bracelet
37RM	Pink PVD coating, with steel bracelet
TIN / TINR	
	Titanium

DIAL VARIATION	
AID / AID2	Silver / Golden indices
AIN / AIN2	Silver / Silver indices
AINO	Silver / Black indices
AIR	Silver / Pink indices
ABD	Silver / Golden Breguet numberings
ABN	Silver / Silver Breguet numberings
ABR	Silver / Pink Breguet numberings
ABUN	Silver / Blue indices
AR	Silver / Roman numberings
BID	White / Golden indices
BIN	White / Silver indices
BINCU	White / Silver indices / Curling Edition
BIR	White / Pink indices
BRIN	Brown / Silver indices
BRIR	Brown / Pink indices
BU	Blue dial
BUBN	Blue / Silver Breguet numberings
BUID	Blue / Golden indices
BUIN	Blue / Silver indices
BUV3	Blue / Green indices
GBD	Grey / Golden Breguet numberings
GBR	Grey / Pink Breguet numberings
GID	Grey / Golden indices
GIN	Grey / Silver indices
GIR	Grey / Pink indices
NADN	Mother-of-pearl / Golden indices
NAIN	Mother-of-pearl / Silver indices
NANN	Mother-of-pearl / Black indices
NAIR	Mother-of-pearl / Pink indices
NBN	Black / Silver Breguet numberings
NBUJ	Black / Blue and yellow indices
NBUN	Black / Blue indices
NBUR	Black / Blue and pink indices
NBR	Black / Pink Breguet numberings
NBU	Black / Blue indices
NIO	Black / Orange indices
NID	Black / Golden indices
<b>NIN / NIN2</b>	Black / Silver indices
NINCU	Black / Silver indices / Curling Edition
NIR	Black / Pink indices
NIRD	Black / Pink indices, diamonds
NBUR	Black / Blue and red indices
NOBU	Black / Orange and blue indices
NOJ	Black / Orange and yellow indices
NOR	Black / Orange indices
NRO	Black / Red indices
NW	Black / Green indices
ROIN	Pink / Black indices
ROIR	Pink / Pink indices
ROUIR	Red / Pink indices

CHRONORALLY  
10302 37N NIN Ø 45 MM

**10302 37N NIN**  
MOVEMENT  
The first 2 or 3 digits of these five figures represent the Edox movement code. Please refer to the page 169-173 of this catalogue.

**10302 37N NIN**  
CASE MATERIAL  
The digits and/or letters represent the material and surface treatment (colour) of the case. (See the table)

**10302 37N NIN**  
DIAL VARIATIONS  
The digits and letters represent the colour and design of the dial.

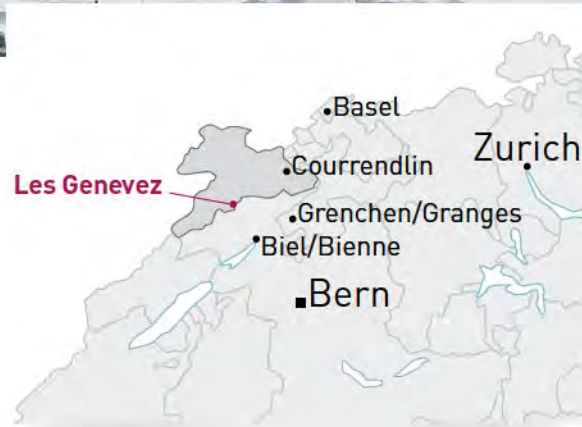

Visit Edox at [www.edox.ch](http://www.edox.ch)



**EDOX SWISS WATCHES**

LA SAGNE AU DROZ  
CH-2714 LES GENEVEZ  
SWITZERLAND

TEL. +41 32 484 70 10 FAX. +41 32 484 70 19  
INFO@EDOX.CH WWW.EDOX.CH

FACEBOOK & TWITTER

The models and product lines in this 2017-2018 catalogue are subject to change without notice. All models are subject to availability. The information provided refers to the model named, or is of a general nature. Not all watches and movements in this catalogue are shown in their actual size. The colours of the watches and movements illustrated may vary due to the printing process. No part of this brochure may be reproduced, scanned or transmitted either online or in any form without prior written permission from Edox.

Edox is a registered trademark.

Printed in Switzerland







CHRONOGRAPH AUTOMATIC  
01121 357RN GR  
PAGE 12



CHRONOGRAPH AUTOMATIC  
01123 357RCA NBUR  
PAGE 12



CHRONOGRAPH AUTOMATIC  
01123 3ORCA ABUN  
PAGE 12



CHRONOGRAPH AUTOMATIC  
01123 3BUCA NBUN  
PAGE 12



**NEW**  
AUTOMATIC PHANTOM OF TIME  
85301 357RN NIR  
PAGE 13



**NEW**  
AUTOMATIC PHANTOM OF TIME  
85301 371AID  
PAGE 13



**NEW**  
AUTOMATIC PHANTOM OF TIME  
85301 3AIN  
PAGE 13



**GRAND OCEAN**

**NEW**  
AUTOMATIC PHANTOM OF TIME  
85301 3 GIN  
PAGE 13



AUTOMATIC DAY DATE  
88002 357RCA AIR  
PAGE 14



AUTOMATIC DAY DATE  
88002 357RCA NIR  
PAGE 14



AUTOMATIC DAY DATE  
88002 3ORCA A BUN  
PAGE 14



AUTOMATIC DAY DATE  
88002 3CA NIN  
PAGE 14



CHRONOMETER  
80077 3 NEN  
PAGE 15



CHRONOMETER  
80077 3ABN  
PAGE 15



**GRAND OCEAN**

OPEN HEART AUTOMATIC  
85008 3 NIN  
PAGE 15



OPEN VISION AUTOMATIC  
85013 357JAID  
PAGE 17



OPEN HEART AUTOMATIC  
85013 3 NIN  
PAGE 15



OPEN VISION AUTOMATIC  
85013 3AIN  
PAGE 17



OPEN VISION AUTOMATIC  
85012 357JIN NID  
PAGE 18



OPEN VISION AUTOMATIC  
85012 357JAID  
PAGE 18



OPEN VISION AUTOMATIC  
85012 357N NIN  
PAGE 18



**GRAND OCEAN**

OPEN VISION AUTOMATIC  
85013 3AIN  
PAGE 18



CHRONOGRAPH  
10226 357JBUCA BUID  
PAGE 19



CHRONOGRAPH  
10226 357RCA NIR  
PAGE 19



CHRONOGRAPH  
10226 3BUCA BUN  
PAGE 19



CHRONOGRAPH  
10226 3CA NBUN  
PAGE 19



ULTRA SLIM  
56002 3JC AID  
PAGE 21



ULTRA SLIM  
56002 357RC NIR  
PAGE 21



**GRAND OCEAN**

ULTRA SLIM  
56002 3C NIN  
PAGE 21



ULTRA SLIM  
56002 3C AIN  
PAGE 21



ULTRA SLIM  
56002 3C BUN  
PAGE 21



CHRONOGRAPH AUTOMATIC  
01122 3M BUN  
PAGE 26



CHRONOGRAPH AUTOMATIC  
01122 3NM BUINO  
PAGE 26



CHRONOGRAPH AUTOMATIC  
01122 3M NIN  
PAGE 26



CHRONOGRAPH AUTOMATIC  
01122 3 BUN  
PAGE 26



**CO-1**

CHRONOGRAPH AUTOMATIC  
01122 3N BUINO  
PAGE 26



CHRONOGRAPH AUTOMATIC  
01122 3 NIN  
PAGE 26



CHRONOGRAPH AUTOMATIC  
01122 3BN BINN  
PAGE 27



CHRONOGRAPH AUTOMATIC  
01122 3BN BINN  
PAGE 27



CHRONOGRAPH AUTOMATIC  
01122 37R NIR  
PAGE 27



OFFSHORE-1 PROFESSIONAL  
80099 3M NIN  
PAGE 28



OFFSHORE-1 PROFESSIONAL  
80099 30M NINO  
PAGE 28



**CO-1**

OFFSHORE-1 PROFESSIONAL  
80099 3RM NIN  
PAGE 28



OFFSHORE-1 PROFESSIONAL  
80099 37R NIR  
PAGE 28



OFFSHORE-1 PROFESSIONAL  
80099 30 NINO  
PAGE 28



OFFSHORE-1 PROFESSIONAL  
80099 3R NIN  
PAGE 28



CHRONOGRAPH **NEW**  
10221 37RBUT BIR7  
PAGE 29



CHRONOGRAPH **NEW**  
10221 37RBUT BUI7  
PAGE 29



CHRONOGRAPH **NEW**  
10221 3BU7 BUI7  
PAGE 29



CHRONOGRAPH  
10221 357RM BIR  
PAGE 31



CHRONOGRAPH  
10221 3NN BUINO  
PAGE 31



CHRONOGRAPH  
10221 3M NIN  
PAGE 31



CHRONOGRAPH  
10221 357R BIR  
PAGE 31



CHRONOGRAPH  
10221 3N BUINO  
PAGE 31



CHRONOGRAPH  
10221 3 NIN  
PAGE 31



CHRONOGRAPH  
10221 37R NIR  
PAGE 33



CHRONOLADY  
10221 37N NINJ  
PAGE 33



CHRONOLADY  
10225 37R BIRR  
PAGE 34



CHRONOLADY  
10225 37RB BIR  
PAGE 34



CHRONOLADY  
10225 3N BUIN  
PAGE 34



CHRONOLADY  
10225 3B BUIN  
PAGE 34



CHRONOLADY  
10225 3B BUIN  
PAGE 34



CHRONOLADY  
10411 37NR/20D NANN  
PAGE 35



CHRONOLADY  
10411 37N NANN  
PAGE 35



CHRONORALLY LIMITED EDITION **NEW**  
38001 TINNI NIBU1  
PAGE 40



CHRONORALLY **NEW**  
38001 TINBUT BUIB1  
PAGE 44



CHRONORALLY  
38001 TIN AIN  
PAGE 44



CHRONORALLY  
38001 TIN NIN  
PAGE 44



CHRONORALLY  
10302 3V2 BUV3  
PAGE 45



CHRONORALLY  
10302 3 GR3  
PAGE 45



**CHRONORALLY**

CHRONORALLY  
10302 37NJ NOJ3  
PAGE 45



CHRONORALLY  
10302 3M NIN2  
PAGE 46



CHRONORALLY  
10302 3MV GIN  
PAGE 46



CHRONORALLY  
10302 3M GIN  
PAGE 46



CHRONORALLY  
10302 3M BUIN  
PAGE 46



CHRONORALLY  
10302 3M AIN  
PAGE 46



CHRONORALLY  
10302 37N NIN  
PAGE 48



CHRONORALLY  
10302 3 NIN2  
PAGE 48



CHRONORALLY  
10302 3 AIN  
PAGE 48



CHRONORALLY  
10302 3V GIN  
PAGE 48



CHRONORALLY  
10302 37N GIN  
PAGE 49



CHRONORALLY  
10302 3 GIN  
PAGE 49



CHRONORALLY  
10302 3 BUIN  
PAGE 49



CHRONORALLY PH AUTOMATIC  
01118 37NR NRO  
PAGE 54



**CHRONORALLY 1**

CHRONOGRAPH AUTOMATIC  
01183 NO  
PAGE 54



AUTOMATIC  
80094 3M NV  
PAGE 54



AUTOMATIC  
80094 3 NN  
PAGE 54



CHRONORALLY  
10305 3M NV  
PAGE 55



CHRONORALLY  
10305 3M NV  
PAGE 55



CHRONOGRAPH **NEW**  
10227 3NBUM BUBN  
PAGE 60



CHRONOGRAPH **NEW**  
10227 3M ABN  
PAGE 60



CHRONORALLY 1

CHRONORALLY-5

CHRONOGRAPH **NEW**  
10229 3M NBN  
PAGE 60



CHRONOGRAPH **NEW**  
10227 7NCA NINN  
PAGE 61



CHRONOGRAPH **NEW**  
10227 37RCA ABR  
PAGE 61



CHRONOGRAPH **NEW**  
10227 357RCA NBR  
PAGE 61



CHRONOGRAPH **NEW**  
10227 3NBUCA BUBN  
PAGE 61



CHRONOGRAPH **NEW**  
10229 3CA NBN  
PAGE 61



CHRONOGRAPH **NEW**  
10229 3NBUM BUBN  
PAGE 62



CHRONORALLY-5

CHRONOGRAPH **NEW**  
10229 3M AIN  
PAGE 62



CHRONOGRAPH **NEW**  
84300 3M NIN  
PAGE 62



CHRONOGRAPH **NEW**  
10229 37RCA AIR  
PAGE 63



CHRONOGRAPH **NEW**  
10229 357RCA NIR  
PAGE 63



CHRONOGRAPH **NEW**  
10229 3NBUCA BUBN  
PAGE 63



CHRONOGRAPH **NEW**  
10229 3CA NIN  
PAGE 63



3-HANDS **NEW**  
84300 3NBUM BUBN  
PAGE 64



CHRONORALLY-5

3-HANDS **NEW**  
84300 3M ABN  
PAGE 64



3-HANDS **NEW**  
84300 3M NBN  
PAGE 64



3-HANDS **NEW**  
84300 37RCA NBR  
PAGE 65



3-HANDS **NEW**  
84300 3NBUCA BUBN  
PAGE 65



3-HANDS **NEW**  
84300 3CA ABN  
PAGE 65



3-HANDS **NEW**  
84300 3CA NBN  
PAGE 65



DELFIN FLEET 1450 LIMITED  
EDITION **NEW**  
88004 BRZBU BUI



CHRONORALLY-5

DELFIN

DELFIN FLEET 1450 LIMITED  
EDITION **NEW**  
88004 3 NIN  
PAGE 71



OPEN HEART  
85024 37GRM GIR  
PAGE 72



OPEN HEART  
85024 3BUM AIN  
PAGE 72



OPEN HEART  
85024 3M AIN  
PAGE 72



OPEN HEART  
85024 3M NIN  
PAGE 72



OPEN HEART  
85024 3M BUBN  
PAGE 72



CHRONOGRAPH **NEW**  
10109 357RBUM NIR  
PAGE 74



DELFIN

CHRONOGRAPH **NEW**  
10109 3M BUBN  
PAGE 74



CHRONOGRAPH **NEW**  
10109 3M AIN  
PAGE 74



CHRONOGRAPH **NEW**  
10109 357RCA NIRG  
PAGE 74



CHRONOGRAPH **NEW**  
10109 3CA BUBN  
PAGE 74



CHRONOGRAPH **NEW**  
10109 3CA AIN  
PAGE 74



CHRONOGRAPH **NEW**  
10109 357JMYVID  
PAGE 75



CHRONOGRAPH **NEW**  
10109 3M NIN  
PAGE 75



DELFIN

CHRONOGRAPH  
10108 3BUAIN  
PAGE 75



CHRONOGRAPH **NEW**  
10109 357NCA NINB  
PAGE 75



CHRONOGRAPH **NEW**  
10109 357NCA NIN  
PAGE 75



CHRONOGRAPH **NEW**  
10110 357JMAID  
PAGE 76



CHRONOGRAPH **NEW**  
10110 357JCA AID  
PAGE 76



CHRONOGRAPH **NEW**  
10110 357RCA AIR  
PAGE 76



CHRONOGRAPH **NEW**  
10110 357RCA NIR  
PAGE 76



CHRONOGRAPH **NEW**  
10110 3M BUIN  
PAGE 77



CHRONOGRAPH **NEW**  
10110 3M AIN  
PAGE 77



CHRONOGRAPH **NEW**  
10110 3M NIN  
PAGE 77



CHRONOGRAPH **NEW**  
10110 3CA BUIN  
PAGE 77



CHRONOGRAPH **NEW**  
10110 3CA AIN  
PAGE 77



CHRONOGRAPH **NEW**  
10110 3CA NIN  
PAGE 77



3-HANDS  
53005 37GRM GIR  
PAGE 78



3-HANDS  
53005 3M BUIN  
PAGE 78



3-HANDS  
53005 3M AIN  
PAGE 78



3-HANDS  
53005 3M NIN  
PAGE 78



3-HANDS  
53005 3M BUIN  
PAGE 78



3-HANDS  
54004 37GRM GIR  
PAGE 79



3-HANDS  
54004 3M AIN  
PAGE 79



3-HANDS  
54004 3M BUIN  
PAGE 79



3-HANDS  
54004 3M NIN  
PAGE 79



3-HANDS  
54004 3M AIN  
PAGE 79



3-HANDS  
54004 3BUAIN  
PAGE 79



LAPASSION

OPEN HEART  
85025 37RM AIR  
PAGE 84



OPEN HEART  
85025 37RM ARR  
PAGE 84



OPEN HEART  
85025 37RM BRIR  
PAGE 84



OPEN HEART  
85025 37RC AIR  
PAGE 84



OPEN HEART  
85025 37RC ARR  
PAGE 84



OPEN HEART  
85025 37RC BRIR  
PAGE 84



OPEN HEART  
85025 37RM NIR  
PAGE 85



OPEN HEART  
85025 37RC NIR  
PAGE 85



OPEN HEART  
85025 37RC ROUIR  
PAGE 85



OPEN HEART  
85025 357RM AIR  
PAGE 86



OPEN HEART  
85025 357RM ARR  
PAGE 86



OPEN HEART  
85025 357RM NIR  
PAGE 86



OPEN HEART  
85025 357RC AIR  
PAGE 86



OPEN HEART  
85025 357RC ARR  
PAGE 86



OPEN HEART  
85025 357RC NIR  
PAGE 86



OPEN HEART  
85025 3M AIN  
PAGE 88



OPEN HEART  
85025 3M ARN  
PAGE 88



OPEN HEART  
85025 3M BUIN  
PAGE 88



OPEN HEART  
85025 3C AIN  
PAGE 88



OPEN HEART  
85025 3C ARN  
PAGE 88



OPEN HEART  
85025 3C BUIN  
PAGE 88



OPEN HEART  
85025 3M NIN  
PAGE 89



OPEN HEART  
85025 3M ROIN  
PAGE 89



OPEN HEART  
85025 3C NIN  
PAGE 89



OPEN HEART  
85025 3C ROIN  
PAGE 89



LAPASSION

CHRONOGRAPH  
10220 37 RM AIR  
PAGE 90



CHRONOGRAPH  
10220 37 RM AR  
PAGE 90



CHRONOGRAPH  
10220 37 RM BRIR  
PAGE 90



CHRONOGRAPH  
10220 37 RC AIR  
PAGE 90



CHRONOGRAPH  
10220 37 RC AR  
PAGE 90



CHRONOGRAPH  
10220 37 RC BRIR  
PAGE 90



CHRONOGRAPH  
10220 37 RM NIR  
PAGE 91



LAPASSION

CHRONOGRAPH  
10220 37 RC NIR  
PAGE 91



CHRONOGRAPH  
10220 37 RC ROIR  
PAGE 91



CHRONOGRAPH  
10220 357 RM AIR  
PAGE 92



CHRONOGRAPH  
10220 357 RM AR  
PAGE 92



CHRONOGRAPH  
10220 357 RM NIR  
PAGE 92



CHRONOGRAPH  
10220 357 RC AIR  
PAGE 92



CHRONOGRAPH  
10220 357 RC AR  
PAGE 92



LAPASSION

CHRONOGRAPH  
10220 3M NIR  
PAGE 92



CHRONOGRAPH  
10220 3M AIN  
PAGE 94



CHRONOGRAPH  
10220 3M AR  
PAGE 94



CHRONOGRAPH  
10220 3M BUIN  
PAGE 94



CHRONOGRAPH  
10220 3C AIN  
PAGE 94



CHRONOGRAPH  
10220 3C AR  
PAGE 94



CHRONOGRAPH  
10220 3C BUIN  
PAGE 94



LAPASSION

CHRONOGRAPH  
10220 3M NIN  
PAGE 95



CHRONOGRAPH  
10220 3M ROIN  
PAGE 95



CHRONOGRAPH  
10220 3C NIN  
PAGE 95



CHRONOGRAPH  
10220 3C ROIN  
PAGE 95



2-HANDS  
57002 37 RM AIR  
PAGE 96



2-HANDS  
57002 37 RM AR  
PAGE 96



2-HANDS  
57002 37 RM BRIR  
PAGE 96



LAPASSION

2-HANDS  
57002 37 RC AIR  
PAGE 96



2-HANDS  
57002 37 RC AR  
PAGE 96



2-HANDS  
57002 37 RC BRIR  
PAGE 96



2-HANDS  
57002 37 RM NIR  
PAGE 97



2-HANDS  
57002 37 RC NIR  
PAGE 97



2-HANDS  
57002 37 RC ROIR  
PAGE 97



2-HANDS  
57002 357 RM AIR  
PAGE 98



LAPASSION

2-HANDS  
57002 357RM AR  
PAGE 98



2-HANDS  
57002 357RM NIR  
PAGE 98



2-HANDS  
57002 357RC AR  
PAGE 98



2-HANDS  
57002 357RC AR  
PAGE 98



2-HANDS  
57002 357RC NIR  
PAGE 98



2-HANDS  
57002 3M AIN  
PAGE 100



2-HANDS  
57002 3M AR  
PAGE 100



2-HANDS  
57002 3M BUIN  
PAGE 100



2-HANDS  
57002 3C AIN  
PAGE 100



2-HANDS  
57002 3C AR  
PAGE 100



2-HANDS  
57002 3C BUIN  
PAGE 100



2-HANDS  
57002 3M NIN  
PAGE 101



2-HANDS  
57002 3M ROIN  
PAGE 101



2-HANDS  
57002 3C NIN  
PAGE 101



2-HANDS  
57002 3C ROIN  
PAGE 101



LES BÉMONTS C. R. F.  
LIMITED EDITION  
95005 3 AIR  
PAGE 106



CHRONOGRAPH AUTOMATIC  
01120 37RM GIR  
PAGE 108



CHRONOGRAPH AUTOMATIC  
01120 37RM AIR  
PAGE 108



CHRONOGRAPH AUTOMATIC  
01120 37R GIR  
PAGE 108



CHRONOGRAPH AUTOMATIC  
01120 37RAIR  
PAGE 108



CHRONOGRAPH AUTOMATIC  
01120 3M GN  
PAGE 109



LAPASSION

LES BÉMONTS

CHRONOGRAPH AUTOMATIC  
01120 3M BUIN  
PAGE 109



CHRONOGRAPH AUTOMATIC  
01120 3M AIN  
PAGE 109



CHRONOGRAPH AUTOMATIC  
01120 3 GN  
PAGE 109



CHRONOGRAPH AUTOMATIC  
01120 3 BUIN  
PAGE 109



CHRONOGRAPH AUTOMATIC  
01120 3 AIN  
PAGE 109



AUTOMATIC SHADE OF TIME **NEW**  
85300 37 R GIR  
PAGE 113



AUTOMATIC SHADE OF TIME **NEW**  
85300 37RAIR  
PAGE 113



LES BÉMONTS

AUTOMATIC SHADE OF TIME **NEW**  
85300 37J AID  
PAGE 113



AUTOMATIC SHADE OF TIME **NEW**  
85300 3 NIN  
PAGE 113



AUTOMATIC SHADE OF TIME **NEW**  
85300 3 BUIN  
PAGE 113



AUTOMATIC SHADE OF TIME **NEW**  
85300 3 AIN  
PAGE 113



DAY DATE  
83015 37RM NIR  
PAGE 114



DAY DATE  
83015 37RM BUJR  
PAGE 114



DAY DATE  
83015 37RM BIR  
PAGE 114



LES BÉMONTS

DAY DATE  
83015 37R NIR  
PAGE 114



DAY DATE  
83015 37R BUJR  
PAGE 114



DAY DATE  
83015 37R BIR  
PAGE 114



DAY DATE  
83015 3 NIN  
PAGE 115



DAY DATE  
83015 3 BUIN  
PAGE 115



DAY DATE  
83015 3 BIN  
PAGE 115



OPEN HEART  
85021 37RM NIR  
PAGE 116



LES BÉMONTS

OPEN HEART  
85021 37RM BUJR  
PAGE 116



OPEN HEART  
85021 37RM AIR  
PAGE 116



OPEN HEART  
85021 37R NIR  
PAGE 116



OPEN HEART  
85021 37R BUJR  
PAGE 116



OPEN HEART  
85021 37R AIR  
PAGE 116



OPEN HEART  
85021 3 NIN  
PAGE 117



OPEN HEART  
85021 3 BUIN  
PAGE 117



LES BÉMONTS

OPEN HEART  
85021 3 AIN  
PAGE 117



CHRONOGRAPH COMPLICATION  
10501 37R GIR  
PAGE 118



CHRONOGRAPH COMPLICATION  
10501 37R AIR  
PAGE 118



CHRONOGRAPH COMPLICATION  
10501 37J AID  
PAGE 118



CHRONOGRAPH COMPLICATION  
10601 3 BUIN  
PAGE 118



CHRONOGRAPH COMPLICATION  
10501 3 AIN  
PAGE 118



PERPETUAL CALENDAR  
01602 37R GIR  
PAGE 119



LES BÉMONTS

PERPETUAL CALENDAR  
01602 37J BRID  
PAGE 119



PERPETUAL CALENDAR  
01602 37R AIR  
PAGE 119



PERPETUAL CALENDAR  
01602 37J AID  
PAGE 119



PERPETUAL CALENDAR  
01602 3 NIN  
PAGE 119



PERPETUAL CALENDAR  
01602 3 AIN  
PAGE 119



CHRONOGRAPH MOON PHASE  
01651 37R BUJR  
PAGE 120



CHRONOGRAPH MOON PHASE  
01651 37R AIR  
PAGE 120



LES BÉMONTS

CHRONOGRAPH MOON PHASE  
01651 37R AIR  
PAGE 120



CHRONOGRAPH MOON PHASE  
01651 37J AR  
PAGE 120



CHRONOGRAPH MOON PHASE  
01651 37J AID  
PAGE 120



CHRONOGRAPH MOON PHASE  
01651 3 NIN  
PAGE 121



CHRONOGRAPH MOON PHASE  
01651 3 AR  
PAGE 121



CHRONOGRAPH MOON PHASE  
01651 3 AIN  
PAGE 121



MOON PHASE COMPLICATION  
40002 37R BUJR  
PAGE 122



LES BÉMONTS

MOON PHASE COMPLICATION  
40002 37R AIR  
PAGE 122



MOON PHASE COMPLICATION  
40002 37R AIR  
PAGE 122



MOON PHASE COMPLICATION  
40002 37J AID  
PAGE 122



MOON PHASE COMPLICATION  
40002 37J AID  
PAGE 122



MOON PHASE COMPLICATION  
40002 3 BUIN  
PAGE 123



MOON PHASE COMPLICATION  
40002 3 NIN  
PAGE 123



MOON PHASE COMPLICATION  
40002 3 AR  
PAGE 123



LES BÉMONTS

MOON PHASE COMPLICATION  
40002 3 AIN  
PAGE 123



BIG DATE SMALL SECOND  
64012 37RM NIR  
PAGE 124



BIG DATE SMALL SECOND  
64012 37RM AIR  
PAGE 124



BIG DATE SMALL SECOND  
64012 37R NIR  
PAGE 124



BIG DATE SMALL SECOND  
64012 37R ROIR  
PAGE 124



BIG DATE SMALL SECOND  
64012 37R AIR  
PAGE 124



BIG DATE SMALL SECOND  
64012 3 NIN  
PAGE 125



LES BÉMONTS



BIG DATE SMALL SECOND  
64012 3 AIN  
PAGE 125



SLIM LINE DATE  
56001 37RM GIR  
PAGE 126



SLIM LINE DATE  
56001 37RM AIR  
PAGE 126



SLIM LINE DATE  
56001 37RM NAIR  
PAGE 126



SLIM LINE DATE  
57001 37RM GIR  
PAGE 126



SLIM LINE DATE  
57001 37RM AIR  
PAGE 126



SLIM LINE DATE  
57001 37RM NAIR  
PAGE 126



LES BÉMONTS

SLIM LINE DATE  
56001 37R GIR  
PAGE 127



SLIM LINE DATE  
56001 37R AIR  
PAGE 127



SLIM LINE DATE  
56001 37R NAIR  
PAGE 127



SLIM LINE DATE  
57001 37R GIR  
PAGE 127



SLIM LINE DATE  
57001 37R AIR  
PAGE 127



SLIM LINE DATE  
57001 37R NAIR  
PAGE 127



SLIM LINE DATE  
56001 37R ROIR  
PAGE 128



LES BÉMONTS

SLIM LINE DATE  
56001 37J DI  
PAGE 128



SLIM LINE DATE  
56001 37J AID  
PAGE 128



SLIM LINE DATE  
57001 37R ROIR  
PAGE 128



SLIM LINE DATE  
57001 37J DI  
PAGE 128



SLIM LINE DATE  
57001 37J AID  
PAGE 128



SLIM LINE DATE  
56001 3 GIN  
PAGE 130



SLIM LINE DATE  
56001 3 AIN  
PAGE 130



LES BÉMONTS

SLIM LINE DATE  
56001 3 NAIN  
PAGE 130



SLIM LINE DATE  
57001 3 GIN  
PAGE 130



SLIM LINE DATE  
57001 3 AIN  
PAGE 130



SLIM LINE DATE  
57001 3 NAIN  
PAGE 130



OPEN HEART AUTOMATIC  
85014 37R GIR  
PAGE 136



OPEN HEART AUTOMATIC  
85014 37R AIR  
PAGE 136



OPEN HEART AUTOMATIC  
85014 3 NIN  
PAGE 136



LES VAUBERTS

OPEN HEART AUTOMATIC  
85014 3 AIN  
PAGE 136



OPEN HEART  
85019 37RM GIR  
PAGE 137



OPEN HEART  
85019 37RM AIR  
PAGE 137



OPEN HEART  
85019 3N NIN  
PAGE 137



LES VAUBERTS

OPEN HEART  
85019 3A NAIN  
PAGE 137



OPEN HEART  
85019 3A NAIR  
PAGE 137



OPEN HEART  
85019 3A NAIR  
PAGE 137



LES VAUBERTS

































Maitre Horloger - Les Genevez  
depuis 1884

2017 - 2018

EDOX SWISS WATCHES  
LA SAGNE AU DROZ  
CH-2714 LES GENEVEZ  
SWITZERLAND

TEL. +41 32 484 70 10 FAX. +41 32 484 70 19  
INFO@EDOX.CH WWW.EDOX.CH

## PICTOGRAMS

	ENGLISH	DEUTSCH	ESPAÑOL	РУССКИЙ	日本語	POLSKI	中文	FRANÇAIS	العربية
	Bestseller	Weltweite Top-Seller	El mejor vendido a nivel mundial	Международный бестселлер	世界的ベストセラー	MIEDZYNARODOWY BESTSELLER	全球暢銷款	Meilleure vente	أفضل المبيعات
	MOVEMENTS	WERK	MOVIMIENTOS	МЕХАНИЗМЫ	ムーブメント	MECHANIZM	機芯	MOUVEMENTS	مكناات الساعا
	Automatic	Automatik	Automático	Автоподзавод	オートマチック	MECHANIZM AUTOMATYCZNY	自動機芯	Automatique	أوتوماتيكية
	Manual winding	Handaufzug	Cuerda Manual	Ручной завод	手巻き	NACIAG RĘCZNY	手動上鍊	Remontage manuel	ربط يدوي
	Quartz	Quarz	Cuarzo	Кварц	クォーツ	MECHANIZM KWARCOWY	石英機芯	Quartz	كوارتز
	Chronometer	Chronometer	Cronómetro	Хронометр	クロノメーター	CHRONOMETR	天文表	Chronomètre	كرونومتر
	Exclusively developed for Edox	Exklusives Edox Kaliber	Desarrollado exclusivamente para Edox	Специально разработанные для Edox	エドックスのために特別に開発	STWORZONY WYŁĄCZNIE DLA MARKI EDOX	Edox 専用機芯	Développement exclusif pour Edox	لتصميم حصري لEdox
	FUNCTIONS	FUNKTIONEN	FUNCIONES	ФУНКЦИИ	機能	FUNKCJE	功能	FONCTIONS	الوظائف
	Chronograph	Chronograph	Cronógrafo	ХРОНОГРАФ	クロノグラフ	CHRONOGRAF	計時碼錶	Chronographe	كرونوغراف
	Split time	Zwischenzeit	Tiempo acumulado	Сплит-хронограф	スプリット機能	MIEDZYCZAS	追針	Temps intermédiaire	وقت مستقطع
	Day-date	Tag - Datum	Día - Fecha	День-дата	デイデイト	DATOWNIK	星期日曆	Jour-date	اليوم + التاريخ
	Perpetual Calendar	Perpetueller Kalender	Calendario perpetuo	Вечный календарь	永久カレンダー	WIECZNY KALENDARZ	萬年曆	Calendrier perpétuel	تقويم مستمر
	Retrograde	Retrograd	Retrógrado	Ретроград	レトログラード	FUNKCIA RETROGRADE	逆跳	Rétrograde	مؤشر عكسي
	Moon phases	Mondphase	Fases Lunares	фаза луны	ムーンフェイズ	FAZY KSIĘZYCA	月相盈虧	Phases de lune	مرحلة القمر
	Big date	Grossdatum	Gran fechador	Большая дата	ビックデイト	DUZY DATOWNIK	日期大視窗	Grande date	تاريخ كبير
	Regulator	Regulator	Regulador	Регулятор	レギュレーター	REGULATOR	三針一線	Régulateur	مُنظّم
	GMT	GMT	GMT	GMT	GMT	DRUGA STREFA CZASOWA	兩地時間	GMT	توقيت غرينتش GMT
	Diving bezel	Taucherlunette	Bisel de buceo	Вращающийся безель	ダイビングベゼル	OBROTOWY PIERŚCIEŃ	潛水上圈	Lunette de plongée	إطار خارجي للغوص
	FEATURES	TECHNISCHE ANGABEN	CARACTERISTICAS	ОСОБЕННОСТИ	仕様	CECHY	特色	CARACTÉRISTIQUES	الميزات
	Water resistance	Wasserdicht bis xxx Meter	Resistencia al agua xxx	Водозащита до XXX м	XXXm防水	WODOSZCZELNOŚĆ DO XXX METRÓW	防水深度XXX米	Etanchéité	مقاومة للماء
	Ultra Slim world record	Ultra Slim Weltrekord	Record mundial Ultra-Plano	Ультратонкие мировой рекорд	ウルトラスリム ワールドレコード	ULTRA-SLIM WORLD RECORD	世界超薄	Record du monde Ultra Slim	رقم قياس عالمي في النحافة الفائقة
	Luminescent hands and/or indices	Mit Leuchtstoff beschichtete Zeiger / Indizes	Manecillas y/o indices luminiscentes	Люминесцентные стрелки и/или индексы	夜光針もしくは夜光インデックス	LUMINESCENCYJNE WSKAZÓWKI I/LUB INDEKSY	夜光指針及或刻度	Aiguilles et/ou index luminescents	عقارب و/أو مؤشرات مضيئة
	Sapphire crystal	Saphirglas	Cristal zafiro	Сапфировое стекло	サファイヤガラス	SZKŁO SZAFIROWE	藍寶石水晶	Verre saphir	زجاج كريستال صفيري
	Transparent caseback	Transparenter Gehäuseboden	Fondo de caja transparente	Прозрачная задняя крышка корпуса	シースルー・ケースバック	TRANSPARENTNY DEKIEL	可透視錶背	Fond transparent	الوجه الخلفي للساعة شفاف
	Edox crown and/or pusher with double O'ring	Krone und/oder Drücker mit doppeltem O'ring	Corona y/o pulsador Edox con doble sello	Заводной ключ и/или кнопки Edox с двойным уплотнением	ダブルOリング付き EDOX リュウズ	PODWÓJNA USZCZELKA KORONKI I/LUB PRZYCISKU	Edox雙防水圈錶冠/按鈕	Couronne et/ou poussoir avec double joint O'ring	ناح مع وحدة إقفال مزدوجة
	Helium valve	Heliumventil	Válvula de helio	Гелиевый клапан	ヘリウムバルブ	ZAWÓR HELOWY	排氣氣閥	Valve à hélium	صمام هيليوم
	Screw-down crown	Sicherheitsschraubkrone	Corona de seguridad enroscable	Закручивающаяся защитная коронка	ネジ込み式リュウズ	ZAKRĘCANA KORONKA	旋緊式安全表冠	Couronne vissée	زرتاح مشدود
	Weight	Gewicht	Peso	Вес	重量	WAGA	重量	Poids	الوزن
	Horn-gap	Bandbreite	Ancho de pulso	Расстояние между ушками	ラグ幅	ROZSTAW USZU KOPERTY	錶帶頭銜接處	Entre-corne	الشيك
	Case height	Gehäusehöhe	Espesor del reloj	Толщина корпуса	ケースの厚さ	WYSOKOŚĆ KOPERTY	錶殼高度	Hauteur de boîte	ارتفاع العلبة
	MATERIAL	MATERIAL	MATERIAL	МАТЕРИАЛ	素材	MATERIAL	材質	MATERIAU	المادة
	Stainless steel	Rostfreier Edelstahl	Acero inoxidable	Нержавеющая сталь	ステンレススティール	STAL	不銹鋼	Acier inoxydable	فولاذ غير قابل للصدأ
	Titanium	Titan	Titanio	Титан	チタニウム	TYTAN	鈦合金	Titane	تيتان
	PVD	PVD	PVD	покрытие	PVD	PVD	PVD	PVD	طلاء PVD
	Genuine diamonds	Diamanten	Diamantes Genuinos	Бриллианты	ダイヤモンド	DIAMENTY	鑽石	Diamants véritables	لئاس حقيقي

  
**EDOX**

Maître Horloger - Les Genevez  
depuis 1884

