

ETA 2895-2

COMMUNICATION
TECHNIQUE

TECHNISCHE
MITTEILUNG

TECHNICAL
COMMUNICATION

11 1/2'''

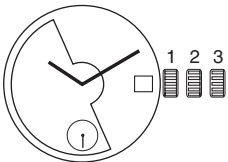
<p>11 1/2''' Ø 25,60 mm</p>	
<p>Hauteur mouvement Werkhöhe Movement height</p>	<p>4,85 mm</p>
<p>Réserve de marche / Gangreserve / Running time</p>	<p>42 h</p>
<p>Nombre de rubis / Anzahl Rubine / Number of jewels</p>	<p>27</p>
<p>Fréquence / Frequenz / Frequency</p>	<p>28'800 A/h</p>
<p>Angle de levée du balancier / Hebungswinkel der Unruh / Angle of lift of balance</p>	<p>51°</p>

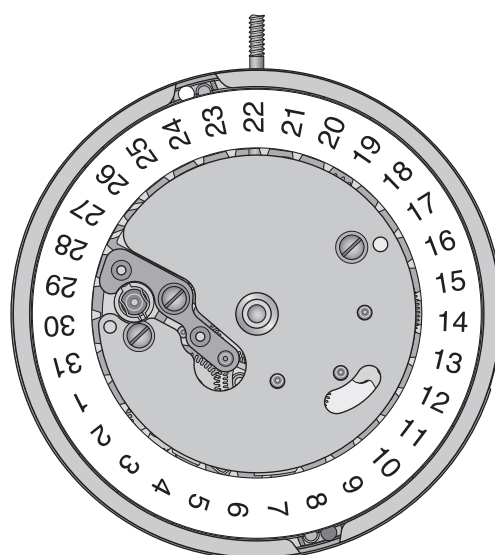
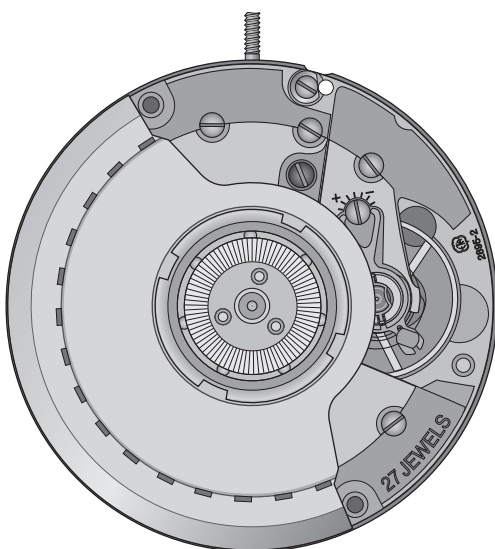

ETA SA Manufacture Horlogère Suisse
Customer Service

Interchangeabilité – Auswechselbarkeit – Interchangeability











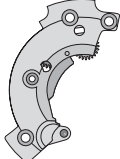







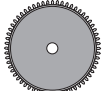































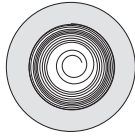

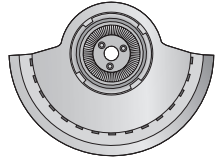



No Nr No	No Nr CS No		LISTE DES FOURNITURES	BESTANDTEILE	LIST OF MATERIALS	Cal. Kal. Cal. 2895-1	Cal. Kal. Cal. 2895-2
100	10.020.07		Platine, empierrée	Werkplatte, mit Steinen	Main plate, jewelled	2895-1	2895-2
105	10.041.07		Pont de barillet, empierré	Federhausbrücke, mit Steinen	Barrel bridge, jewelled	2892A2	2892A2
110	10.048.07		Pont de rouage, empierré	Räderwerkbrücke, mit Steinen	Train wheel bridge, jewelled	2892A2	2892A2
116	10.055.00		Pont de roue d'échappement	Hemmungsradbrücke	Escape wheel bridge	2895-1	2895-1
121/4	10.058.24		Pont de balancier, pour raquette à flèche, amortisseur, porte-piton ETACHRON, correcteur	Unruhbrücke, für Rücker mit Stiel, Stosssicherung, Spiralklotzchenträger ETACHRON, Korrektor	Balance bridge, for regulator with pointer, shock-absorber, stud support ETACHRON, corrector	2892A2	2892A2
125	10.057.07		Pont d'ancre, empierré	Ankerbrücke, mit Steinen	Pallet bridge, jewelled	2892A2	2892A2
129	10.050.07		Pont de roue supplémentaire de rouage, empierré	Brücke für Zusatzräder im Räderwerk, mit Steinen	Additional train wheel bridge, jewelled	2895-1	2895-1
144	10.300.00		Fixateur de cadran	Zifferblatthalter	Dial fastener	2892A2	2892A2
145	10.106.00		Support de cadran	Träger für Zifferblatt	Dial support	2895-1	2895-1
161	80.400.00		Tube de centre	Zentrumlagerrohr	Centre tube	2892A2	2892A2
166	93.030.00	2x	Bride d'emboîtement	Befestigungsplättchen	Casing clamp	2892A2	2892A2
166/1	93.030.18	2x	Bride d'emboîtement, pour boîte étanche	Befestigungsplättchen, für wasserdichtes Gehäuse	Casing clamp, for waterproof case	2892A2	2892A2
180/1	20.010.00		Barillet complet de mouvement	Federhaus vollständig für Grundwerk	Movement barrel complete	2892A2	2892A2
185	20.040.00		Tambour de barillet	Federhaustrommel	Barrel drum	2892A2	2892A2
190	20.050.00		Couvercle de barillet	Federhausdeckel	Barrel cover	2892A2	2892A2
195	20.060.00		Arbre de barillet	Federwelle	Barrel arbor	2892A2	2892A2
203	30.012.00		Roue intermédiaire	Zwischenrad	Intermediate wheel	2892A2	2892A2
204	30.031.00		Roue intermédiaire supplémentaire	Zusatz-Zwischenrad	Additional intermediate wheel	2895-1	2895-1
210	30.025.00		Roue moyenne	Kleinbodenrad	Third wheel	2892A2	2892A2
215	30.029.00		Roue intermédiaire de seconde	Zwischen-Sekundenrad	Intermediate second wheel	2895-1	2895-1
222	30.030.00		Roue de seconde supplémentaire	Zusatz-Sekundenrad	Additional second wheel	2895-1	2895-2
227	30.027.00		Roue de seconde	Sekundenrad	Second wheel	2892A2	2892A2
242	31.083.00		Chaussée avec roue entraîneuse	Minutenrohr mit Mitnehmerrad	Cannon pinion with driving wheel	2892A2	2892A2
255/1	31.046.06		Roue des heures, montée	Stundenrad, montiert	Hour wheel, assembled	2892A2	2892A2
260	31.041.00		Roue de minuterie	Wechselrad	Minute wheel	2892A2	2892A2
303/5	40.302.23		Raquette en 2 pièces, à flèche, pour porte-piton ETACHRON et correcteur	Rücker, zweiteilig, mit Stiel, für Spiralklotzchenträger ETACHRON und Korrektor	Two-piece regulator, with pointer, for stud support ETACHRON and corrector	2892A2	2892A2
358	40.380.00		Correcteur de raquette	Rückerkorrektor	Regular corrector	2892A2	2892A2
375	40.200.00		Porte-piton, monté	Spiralklotzchenträger, montiert	Stud support, assembled	2892A2	2892A2
401	51.010.21		Tige de remontoir, diamètre de filetage 0,90 mm	Aufzugwelle, Gewinde-durchmesser 0,90 mm	Winding stem, thread diameter 0.90 mm	2892A2	2892A2
407	31.121.00		Pignon coulant	Kupplungstrieb	Sliding pinion	2892A2	2892A2
410	31.120.00		Pignon de remontoir	Aufzugtrieb	Winding pinion	2892A2	2892A2
415	31.020.00		Rochet	Sperrrad	Ratchet wheel	2892A2	2892A2
417	31.021.00		Rochet intermédiaire	Zwischen-Sperrrad	Intermediate ratchet wheel	2892A2	2892A2
420	31.023.00		Roue de couronne	Kronrad	Crown wheel	2892A2	2892A2
425	51.120.00		Cliquet	Klinke	Click	2892A2	2892A2
435	51.050.00		Bascule de pignon coulant	Kupplungstriebhebel	Yoke	2892A2	2892A2
443/1	51.080.06		Tirette, montée	Winkelhebel, montiert	Setting lever, assembled	2892A2	2892A2
445/2	51.091.20		Sautoir de tirette combiné	Kombinierte Winkelhebelraste	Combined setting lever jumper	2892A2	2892A2
450	31.100.00		Renvoi	Zeigerstellrad	Setting wheel	2892A2	2892A2
453	31.101.00		Renvoi intermédiaire	Zwischen-Zeigerstellrad	Intermediate setting wheel	2892A2	2892A2
462	10.062.00		Pont de rouage de minuterie	Wechselradbrücke	Minute train bridge	2892A2	2892A2
511	81.086.00		Plaque de cliquet	Klinkenplatte	Click plate	2892A2	2892A2
516	31.024.00		Roue de couronne intermédiaire	Zwischen-Kronrad	Intermediate crown wheel	2892A2	2892A2
705	30.040.00		Roue d'échappement	Hemmungsrad	Escape wheel	2895-1	2895-1
710	40.010.00		Ancre	Anker	Pallet fork	2892A2	2892A2
714	40.020.00		Tige d'ancre	Ankerwelle	Pallet staff	2892A2	2892A2
721	40.050.21		Balancier annulaire, réglé pour amortisseur et porte-piton ETACHRON	Unruh mit glattem Reif, reguliert für Stosssicherung und Spiralklotzchenträger ETACHRON	Timed annular balance, for shock-absorber and stud support ETACHRON	2892A2	2892A2
728	40.100.00		Axe de balancier, pour amortisseur	Unruhwelle, für Stosssicherung	Balance staff, for shock-absorber	2892A2	2892A2
730	40.120.00		Plateau double	Doppelscheibe	Double roller	2892A2	2892A2
771	20.102.00		Ressort-moteur avec ressort de freinage	Triebfeder mit Schleppfeder	Main spring with sliding attachment	2892A2	2892A2

Interchangeability – Auswechselbarkeit – Interchangeability











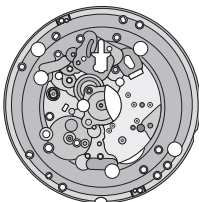

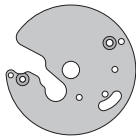
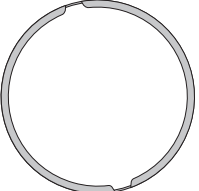
No Nr No	No Nr No	CS	LISTE DES FOURNITURES	BESTANDTEILE	LIST OF MATERIALS	Cal. Kal. Cal. 2895-1	Cal. Kal. Cal. 2895-2
1134	12.030.07		Bâti du dispositif automatique, empierré	Gestell für Automatik, mit Steinen	Automatic device framework, jewelled	2895-1	2895-1
1141	12.051.07		Pont inférieur du dispositif automatique, empierré	Untere Brücke für Automatik, mit Steinen	Automatic device lower bridge, jewelled	2892A2	2892A2
1143/1	22.010.06		Masse oscillante, montée	Schwungmasse, montiert	Oscillating weight, assembled	2892A2	2892A2
1481	32.031.00		Roue de réduction	Reduktionsrad	Reduction wheel	2892A2	2892A2
1482	32.033.00		Roue entraîneuse de rochet	Mitnehmerrad für Sperrrad	Ratchet wheel driving wheel	2892A2	2892A2
1485	52.040.00		Inverseur	Wechsler	Reverser	2892A2	2892A2
1488	32.037.00		Roue d'inversion	Umkehrad	Reversing wheel	2892A2	2892A2
1490	32.032.00		Roue intermédiaire de réduction	Zwischen-Reduktionsrad	Intermediate reduction wheel	2892A2	2892A2
1491	52.120.00		Verrou de masse oscillante	Riegel für Schwungmasse	Oscillating weight bolt	2892A2	2892A2
1497	22.040.00		Roulement à billes	Kugellager	Ball bearing	2892A2	2892A2
1514	15.041.00		Inverseur auxiliaire	Hilfswechsler	Auxiliary reverser	2892A2	2892A2
2536/1	53.251.00		Plaquette supplémentaire de maintien de l'indicateur	Zusatzhalteplättchen für Anzeige	Additional indicator maintaining small plate	2895-1	2895-1
2539	53.022.00		Commande du correcteur de quantité	Schalthebel für Datumkorrektor	Date corrector operating lever	2892A2	2892A2
2543	33.011.00		Roue intermédiaire de quantité	Datum-Zwischenrad	Intermediate date wheel	2895-1	2895-1
2556	33.020.00		Roue entraîneuse de l'indicateur de quantité	Datumanzeiger-Mitnehmerrad	Date indicator driving wheel	2895-1	2895-1
2557/1	91.440.00		Indicateur de quantité, pour ouverture de guichet à 3 heures	Datumanzeiger, für Fenster auf 3 Uhr	Date indicator, for window opening at 3 o'clock	2895-1	2895-1
2566	53.200.00		Correcteur de quantité	Datumkorrektor	Date corrector	2892A2	2892A2
2576	53.080.00		Sautoir de quantité	Datumraste	Date jumper	2895-1	2895-1
2595	13.111.00		Plaque de maintien du sautoir de quantité	Halteplatte für Datumraste	Date jumper maintaining plate	2895-1	2895-1
3024	70.530.00		Amortisseur empierré, de balancier, dessus, à chasser, à portée	Stosssicherung, mit Stein, für Unruh, oben, zum Einpressen, mit Auflage	Jewelled shock-absorber for balance, top, to press-in, shouldered	2892A2	2892A2
3025	70.531.00		Amortisseur, empierré, de balancier, dessous, à chasser, cylindrique	Stosssicherung, mit Stein, für Unruh, unten, zum Einpressen, zylindrisch	Jewelled shock-absorber for balance, bottom, to press-in, cylindrical	2892A2	2892A2
9433	56.070.00		Levier stop	Stopphebel	Stop lever	2892A2	2892A2
1) 5105	10.040.01	3x	Vis de pont de barillet	Schraube für Federhausbrücke	Screw for barrel bridge	2892A2	2892A2
5110	10.048.01	1x	Vis de pont de rouage	Schraube für Räderwerkbrücke	Screw for train wheel bridge	2892A2	2892A2
4) 5116	10.055.01	1x	Vis de pont de roue d'échappement	Schraube für Hemmungsräderbrücke	Screw for escape wheel bridge	2892A2	2892A2
1) 5121	10.058.01	1x	Vis de pont de balancier	Schraube für Unruhbrücke	Screw for balance bridge	2892A2	2892A2
2) 5125	10.057.01	1x	Vis de pont d'ancre	Schraube für Ankerbrücke	Screw for pallet bridge	2892A2	2892A2
4) 5129	10.050.01	2x	Vis de pont de roue supplémentaire de rouage	Schraube für Brücke für Zusatzräder im Räderwerk	Screw for additional train wheel bridge	2892A2	2892A2
5166	93.030.01	2x	Vis de bride d'emboîtage	Schraube für Befestigungsplättchen	Screw for casing clamp	2892A2	2892A2
2) 5445	51.091.01	1x	Vis de sautoir de tirette combiné	Schraube für kombinierte Winkelhebelraste	Screw for combined setting lever jumper	2892A2	2892A2
2) 5462	10.062.01	1x	Vis de pont de rouage de minuterie	Schraube für Wechselradbrücke	Screw for minute train bridge	2892A2	2892A2
3) 5511	81.036.01	1x	Vis de plaque de cliquet	Schraube für Klinkenplatte	Screw for click plate	2892A2	2892A2
51134	12.030.01	3x	Vis de bâti du dispositif automatique	Schraube für Gestell für Automatik	Screw for automatic device framework	2892A2	2892A2
2) 51141	12.051.01	1x	Vis de pont inférieur du dispositif automatique	Schraube für untere Brücke für Automatik	Screw for automatic device lower bridge	2892A2	2892A2
3) 51497	22.040.01	3x	Vis de roulement à billes	Schraube für Kugellager	Screw for ball bearing	2892A2	2892A2
52536	53.251.01	1x	Vis de plaquette supplémentaire de maintien de l'indicateur	Schraube für Zusatzhalteplättchen für Anzeige	Screw for additional indicator maintaining small plate	2892A2	2892A2
52595	13.111.01	1x	Vis de plaque de maintien du sautoir de quantité	Schraube für Halteplatte für Datumraste	Screw for date jumper maintaining plate	2895-1	2895-1
			Vis identiques Identische Schrauben Identical screws	1) 5105 5121	2) 5125 5445 5462 51141	3) 5511 51497	4) 5116 5129

Fournitures – Bestandteile – Materials

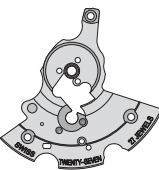
2892A2

											☰	5105 5121		
105	110	121/4	125	144	161	166	166/1	180/1	185	190	☰	5110		
											☰	5125 5445 5462 51141		
195	203	210	227	242	255/1	260	303/5	358	375	401	☰	5116 5129		
													☰	5116 5129
407	410	415	417	420	425	435	443/1	445/2	450	453	462	511	☰	5166
													☰	5511 51497
516	710	714	721	728	730	771	1141	1143/1					☰	51134
													☰	52536
1481	1482	1485	1488	1490	1491	1497	1514	2539	2566	3024	3025	9433	☰	52536

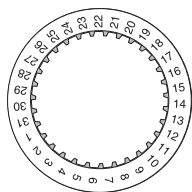
2895-2

							☰	52595
100	116	129	145	204	215	222	☰	52595
								☰
705	1134	2536/1	2543	2556	2557/1	2576	2595	☰

Montage du mouvement de base

(Liste des fournitures par ordre d'assemblage)

Zusammenstellen des Basiswerkes



(Bestandteilliste in Montagereihenfolge)

Assembling of the basic movement

(Parts listed in order of assembly)

100	516	5110 (1x)
407	417	710
410	425	125
401	511	5125 (1x)
161	5511 (1x)	358
3025	105	375
203	5105 (3x)	303/5
180/1	705	3024
415	210	721
1482	227	121/4
420	110	5121 (1x)

Lubrification – Schmierung – Lubrication

Huile fine		
 Düninflüssiges Öl	Moebius 9010	
Fine oil		
Huile épaisse ou graisse		
 Dickflüssiges Öl oder Fett	Moebius D5	
Thick oil or grease		
Huile spéciale pour levées	Moebius 941	
 Spezialöl für Hebungssteine	ou/oder/or	
Special oil for pallet stones	Moebius 9415	

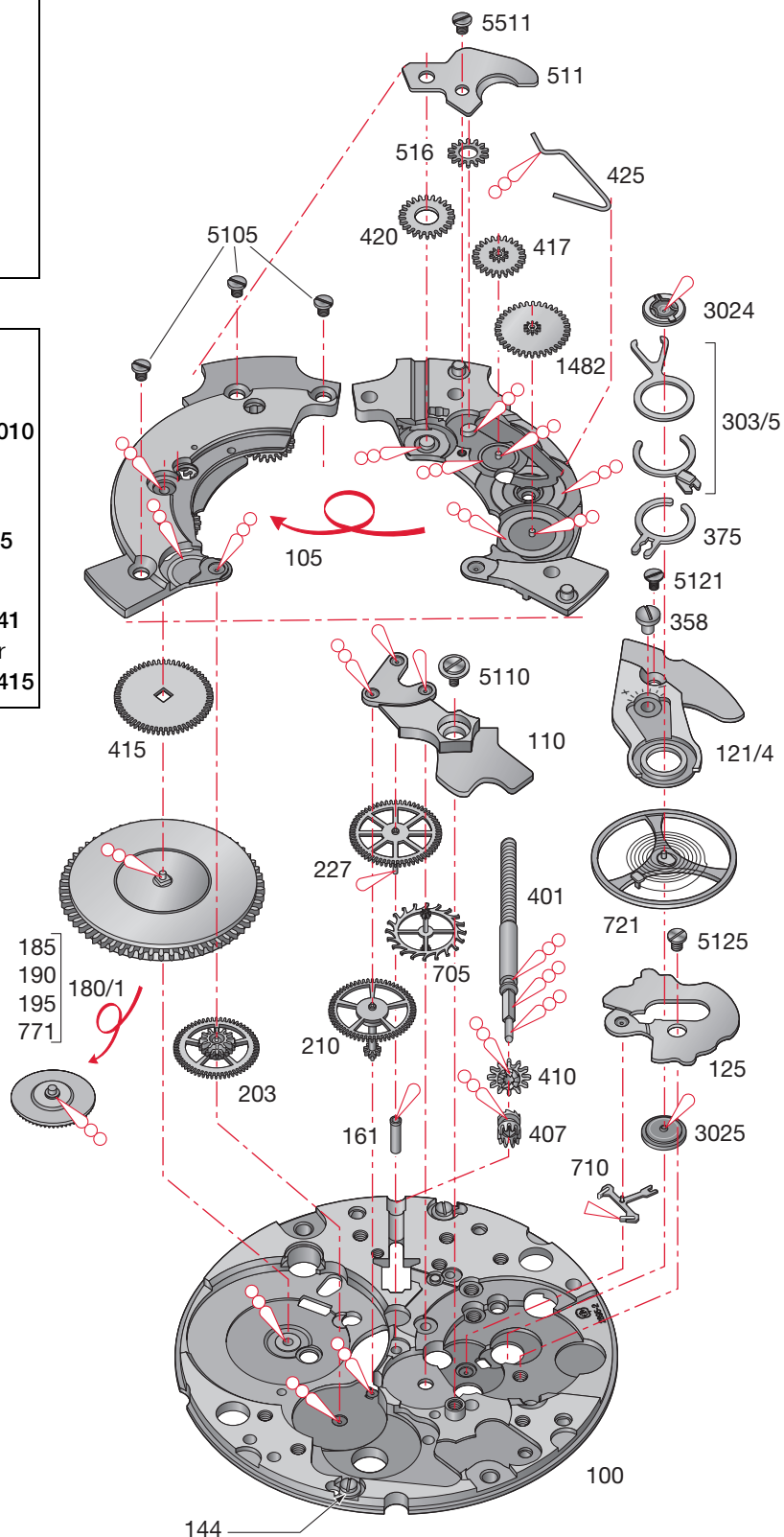

No 1497 : seulement après lavage, très faible lubrification avec Moebius 9010.

Nr 1497 : nur nach Waschen, sehr kleine Menge mit Moebius 9010.

No 1497 : only after washing, use very little oil Moebius 9010.



Montage du mécanisme automatique
(Liste des fournitures par ordre d'assemblage)

Zusammenstellen des Automatikmechanismus
(Bestandteilliste in Montager Reihenfolge)

Assembling of the self-winding mechanism
(Parts listed in order of assembly)

9433	1141	
1134	51141	(1x)
1490	1514	
1481	1143/1	
1488	51497	(3x)
1485	51134	(3x)

Lubrification – Schmierung – Lubrication

- Très faible quantité
-  Sehr kleine Menge **Moebius 9010**
- Very little quantity
- Huile épaisse ou graisse
-  Dickflüssiges Öl oder **Moebius D5**
- Fett
- Thick oil or grease

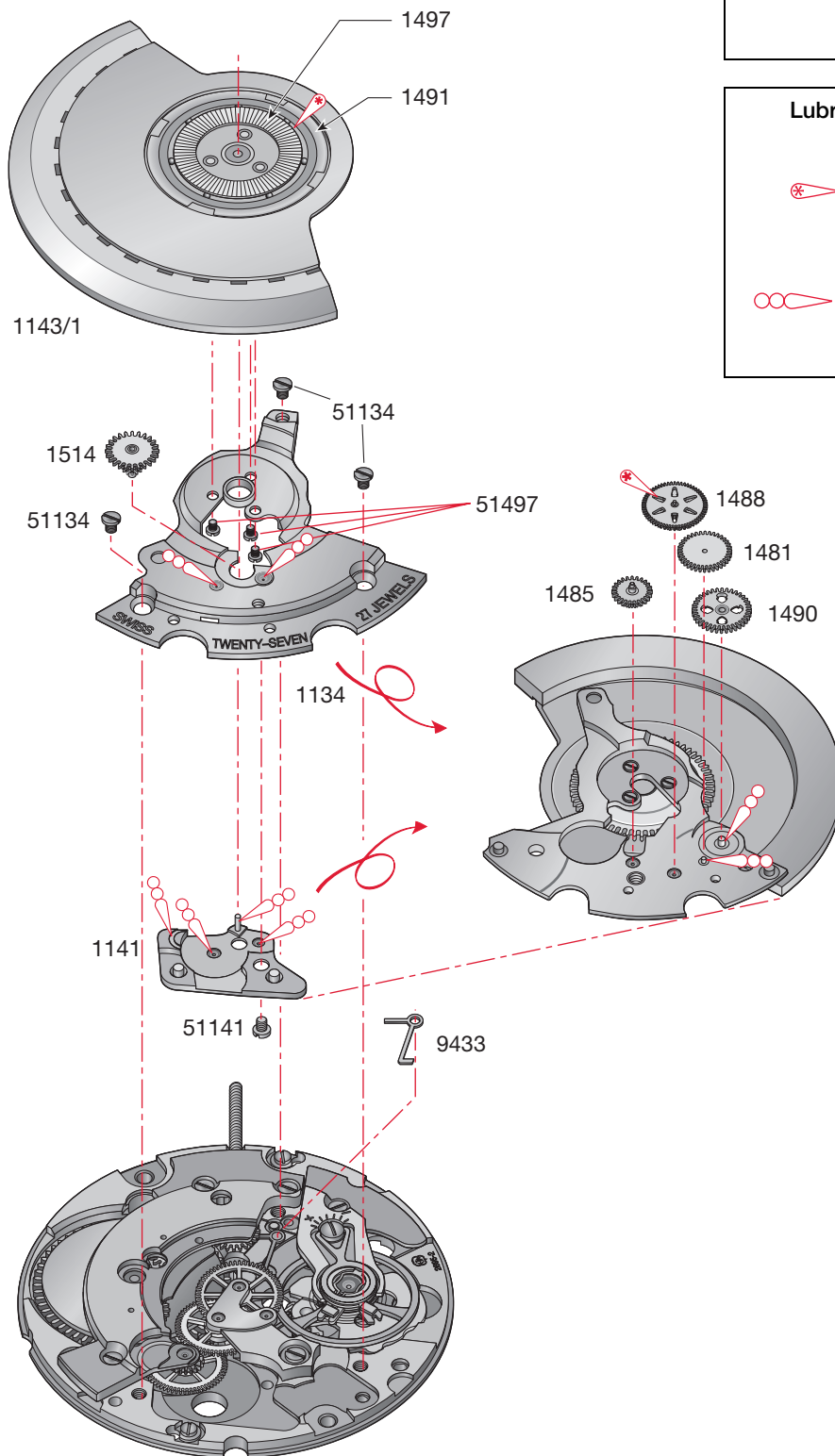

Montage des mécanismes de remontage manuel, mise à l'heure, quantième et correcteur

(Liste des fournitures par ordre d'assemblage)

Zusammenstellen des Handaufzug-, Zeigerwerk-, Datum- und Korrekturmechanismus

(Bestandteilliste in Montagereihenfolge)

Assembling of the hand-winding, hand-setting, date and corrector mechanisms

(Parts listed in order of assembly)

2539	2543		
443/1	2595		
435	52595	(1x)	
445/2	2536/1		
5445 (1x)	52536	(1x)	
242	255/1		
260	215		
450	204		
453	222		
2566	116		
462	5116	(1x)	
5462 (1x)	129		
2556	5129	(2x)	
2557/1	145		
2576			

Lubrification – Schmierung – Lubrication

Huile fine		
 Dünnflüssiges Öl	Moebius 9010	
Fine Öl		
Huile épaisse ou graisse		
 Dickflüssiges Öl oder Fett	Moebius D5	
Thick oil or grease		
Graisse		Jismaa124
Fett		ou/oder/or
Grease		Moebius 9501

Après lavage, contrôler que les aimants n'aient pas retenu de limaille.

Nach dem Waschen kontrollieren, daß keine Feilspäne auf den Magneten zurückgeblieben sind.

After washing, check that no filings remain stuck to the magnets.

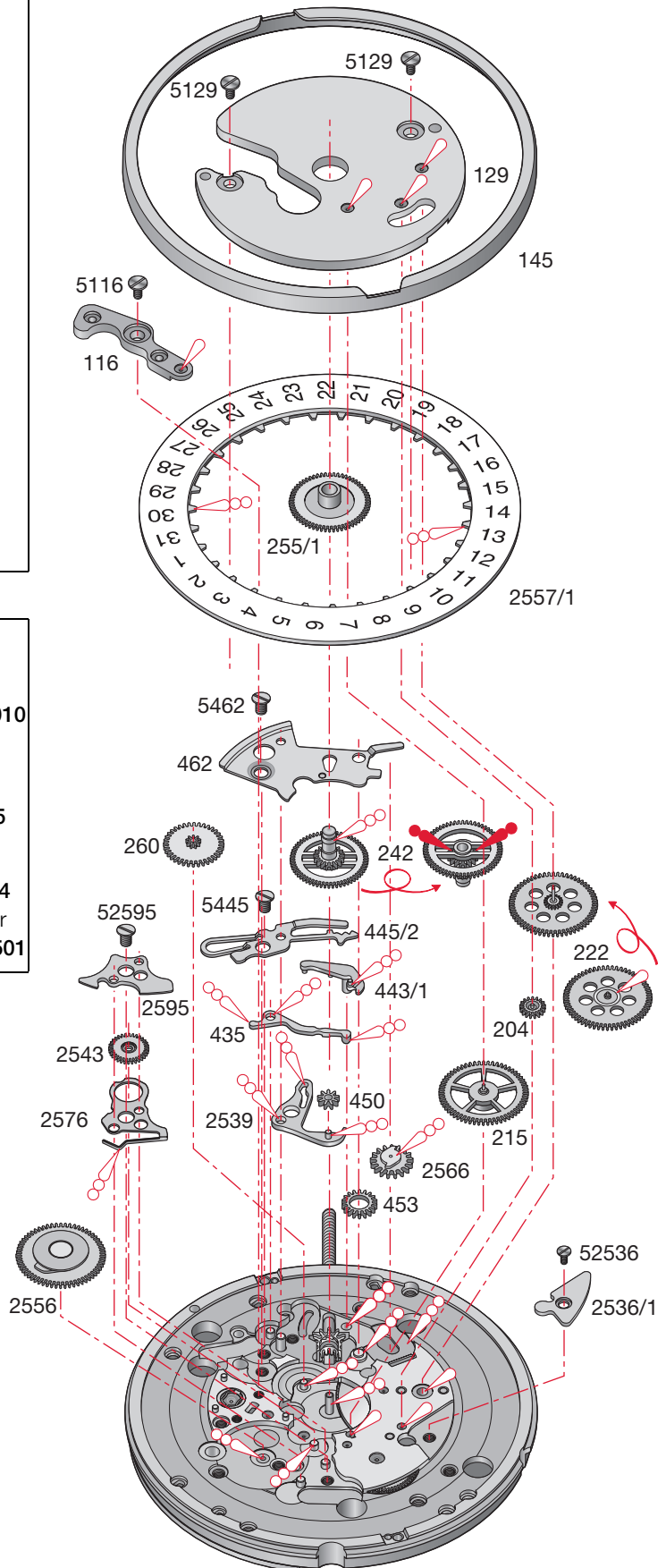

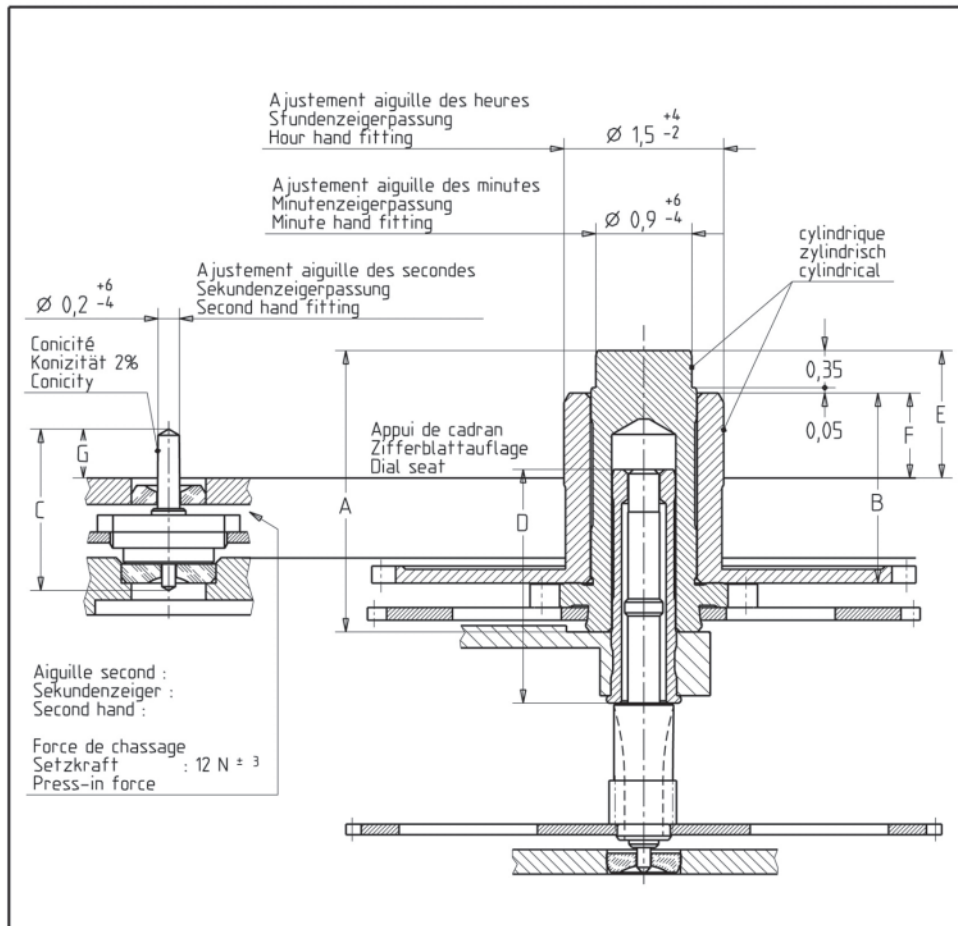

Aiguillage Zeigerwerk- höhe	Longueur / Länge / Length				Dépassement Höhe über Zifferblattauflage Height over dial seat		
	A	B	C	D	E	F	G
Hand fitting height	Chaussée Minutenrohr Cannon-pinion	Roue des heures Stundenrad Hour wheel	Pig. des sec. Sekundentrieb Sec wheel pin.	Tube de centre Zentrumrohr Centre tube	Chaussée Minutenrohr Cannon-pinion	Roue des heures Stundenrad Hour wheel	Pig. des sec. Sekundentrieb Sec wheel pin.
4	2,65	1,79	1,46	2,20	1,20	0,80	0,50
6	3,15	2,29	1,96	2,20	1,70	1,30	1,00

Kaliber / Calibre / Caliber 2895-2		Masstab Echelle Scale		EUCLID321B
		Masse in mm Dimensions en mm Dimensions in mm	Tol. 1/1000 mm	

AIGUILLAGES ZEIGERWERKHÖHEN HAND FITTING HEIGHTS		Z0070491	Version 01	Revision 00	Blatt Feuille Sheet 01
--	--	----------	---------------	----------------	---------------------------------

Ersatz für En remplacement de Remplacement for			Klass. Class. ZVACC	KUN
Aenderung Modification	Geprüft Contrôlé Controlled	Freigegeben Libéré Released	Erstellt Établi Created	Freigegeben Libéré Released
17503	HID 26.02.2003 RIP	26.02.2003 FEU	13.01.2003 FRL	14.01.2003 RIP 15.01.2003 FEU

We reserve all rights for this document. It is meant for the recipient only and it may not be copied, printed or given to a third person without our written permission.

Für dieses Dokument behalten wir uns alle Rechte vor. Es ist nur für den Empfänger bestimmt. Ohne unsere schriftliche Bewilligung darf es nicht kopiert, vervielfältigt und Dritten zugänglich gemacht werden.

Nous nous réservons tous les droits sur ce document. Il est confié au destinataire. Il ne peut, sans notre autorisation écrite, être copié, reproduit, communiqué à des tiers.



ETA SA Manufacture Horlogère Suisse
Customer Service
 Bahnhofstrasse 9
 P.O. Box 359
 CH-2540 Grenchen
 Phone +41 (0)32 655 27 77
 Fax +41 (0)32 655 84 30
 e-mail: etacs@eta.ch
 www.eta.ch

A COMPANY OF THE SWATCH GROUP