

REPAIRING THE ESCAPEMENT

TRAINING UNIT

NUMBER 10A

- SEE PAGE 297-303 INC



HOW TO REPAIR PARTS OF  
THE ESCAPEMENT

BULOVA SCHOOL *of* WATCHMAKING



## REPAIRING THE ESCAPEMENT

*T*HE escapement parts consist of the escape wheel, the pallet, and the roller.

The occasion frequently arises wherein one or more of these parts may require repairs or replacement. For this reason, a correct procedure will be given on how to make these repairs on the major escapement parts. Also, the principles involved in positioning pallet stones will be explained, and a simple rule will be given to determine which stone must be moved, when adjustment is necessary.



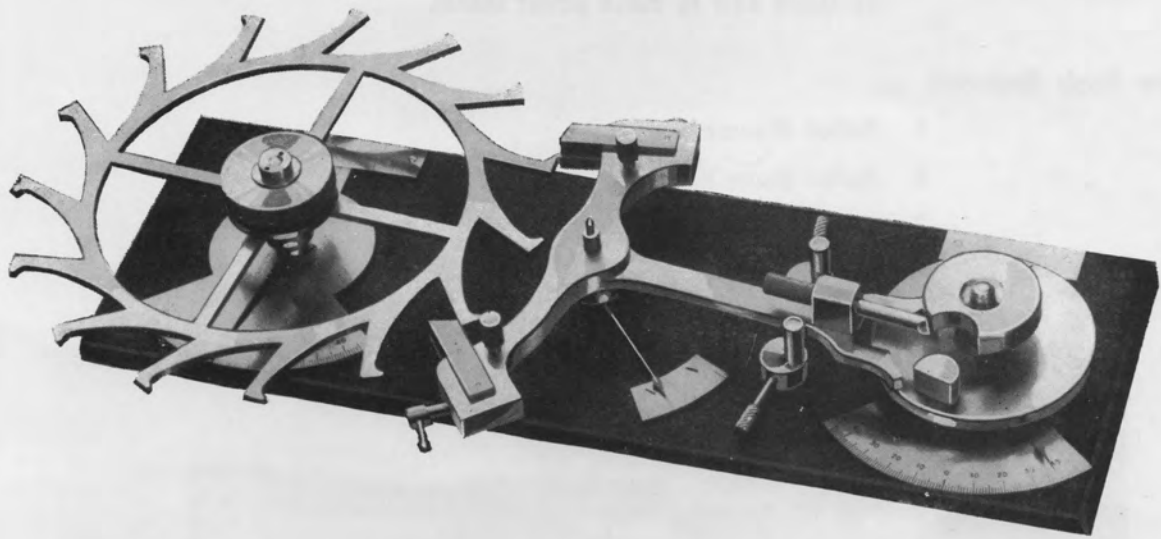

# BULOVA SCHOOL *of* WATCHMAKING

## TRAINING UNIT NUMBER 10A

**SUBJECT:**

Repairing Parts of the Escapement

**Objectives:**

To learn how to repair escapement parts

To learn how to move pallet stones.

**New Tools Required:**

- 1 Pallet Warmer
- 2 Pallet Stone Pusher
- 3 Escapement Tool
- 4 Jewel Pin Warmer

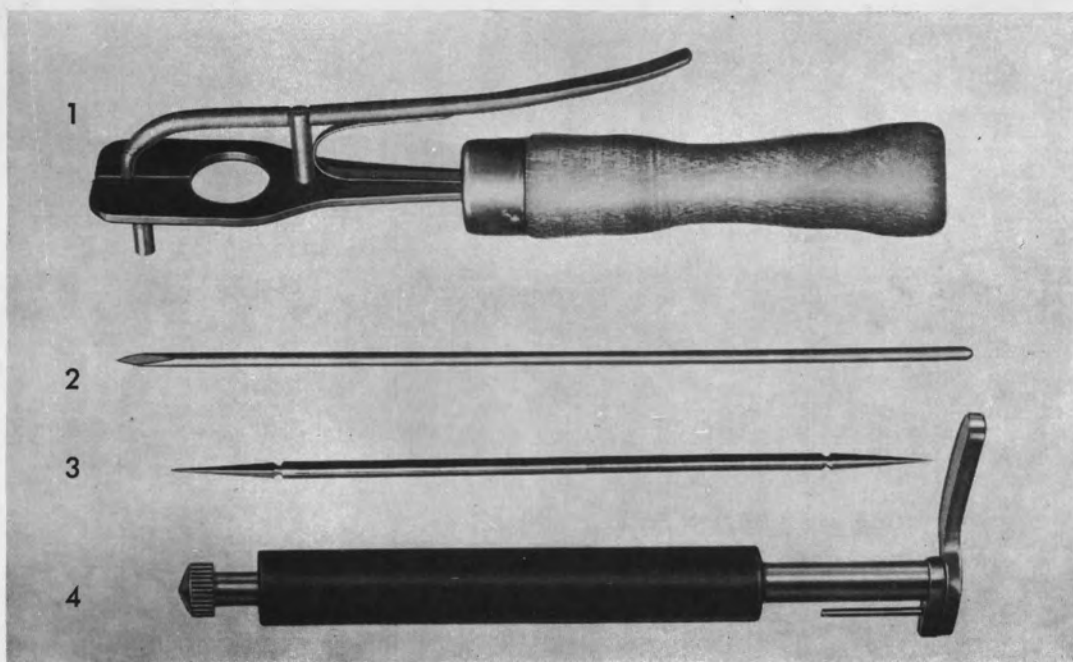

## HOW TO REPAIR THE PARTS OF THE ESCAPEMENT

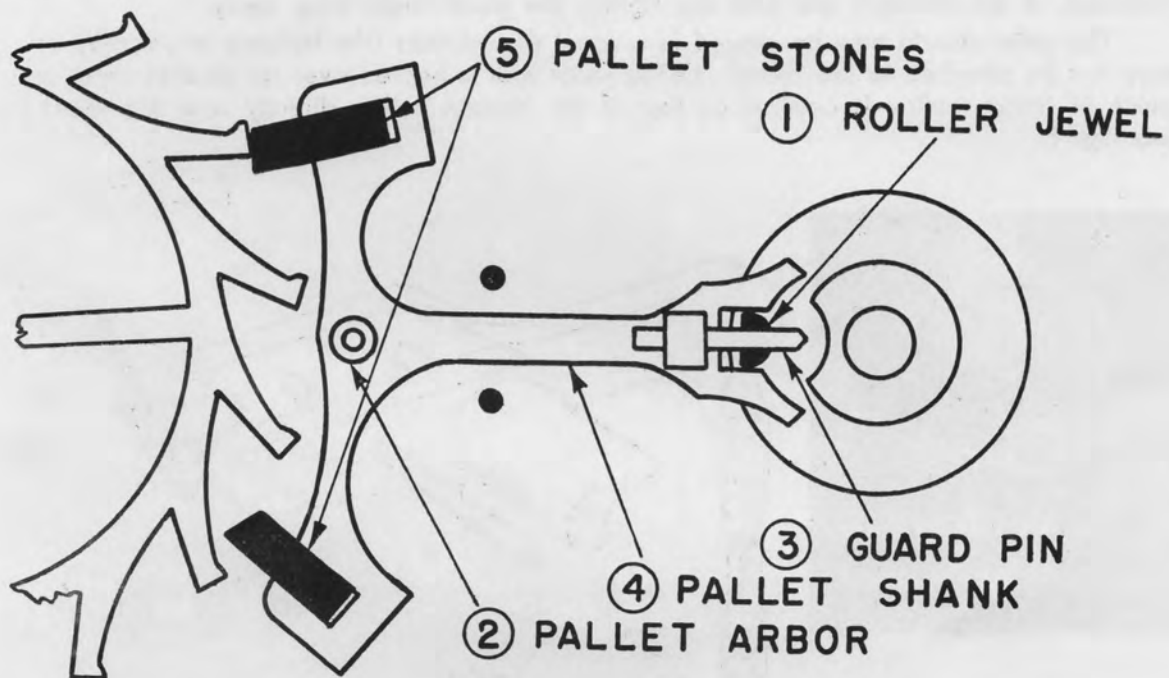

Repairing of these parts will be treated in numerical sequence in the pages which follow.



### No. 1: HOW TO SET A NEW ROLLER JEWEL

If a new roller jewel is to be inserted in the roller, it should first be tried in the fork of the pallet. Obviously, the jewel cannot be larger than the fork slot. On the other hand, a jewel that is too small for the slot will cause lost motion of the pallet. Jewel pin freedom of .01 mm. for small watches to .03 mm. for 16 size watches should permit a safe impulse action.

Now thoroughly clean the roller jewel opening and properly fitted jewel in alcohol to insure permanent adhesion by the shellac.

Place the jewel into the roller, being careful not to apply too much pressure on the tweezers. If the tweezers are held too tightly, the jewel might snap away.

The roller should now be placed in a jewel pin warmer (the balance wheel may or may not be attached to the roller). As the jewel tool is heated over an alcohol lamp, a piece of string shellac is applied on top of the impulse roller, directly over the jewel. See Fig. 1.

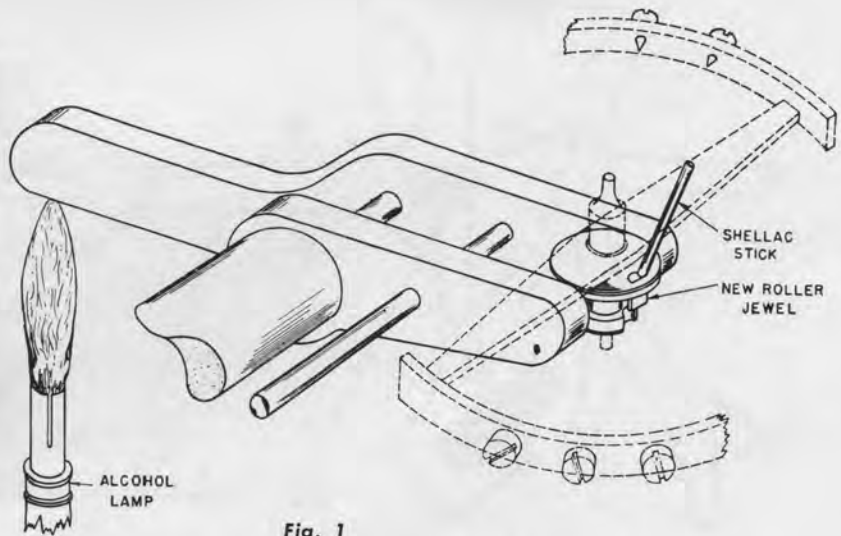

Fig. 1

Care must be taken to insure that the jewel is perpendicular to the roller and also that it will be of proper length. In Fig. 2 are shown a roller jewel which is of proper length, a roller jewel which is too short, and one that is too long.

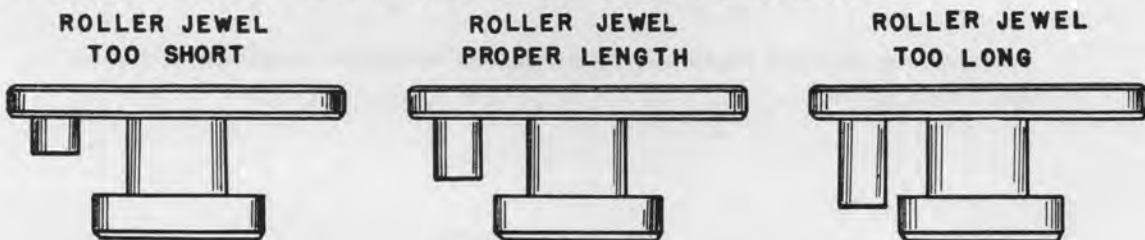

Fig. 2

When the jewel has been set, the balance assembly should be tried in the watch to check its action with the fork of the pallet.

Remove any excess shellac on the jewel with an edged piece of pegwood which has been dipped in alcohol.





## No. 2: PALLET ARBORS

Pallet arbors are constructed in two types: the screw arbor and friction arbor.

The friction type shown in insert of Fig. 3 is inserted or removed from the pallet by the staking method. Fig. 3 shows a punch being tapped against the friction arbor so that it will be inserted in the pallet. The punch which is flat-faced and with hole diameter slightly larger than that of the pivot rests on the shoulder of the arbor. The pallet is supported by a small stump which must not interfere with the pallet jewels.

The pallet is usually positioned slightly below the upper pivot of the arbor but can be shifted to any desirable height. Removal of the friction pallet is accomplished by reversing the process; that is, by driving out instead of driving in the arbor.

The screw type, illustrated in Fig. 4, is threaded on its upper shoulder so that it will screw into the pallet. Insertion or removal of the arbor can be easily performed with the aid of a pin vise which is tightened on the lower shoulder of the arbor.

Fig. 3

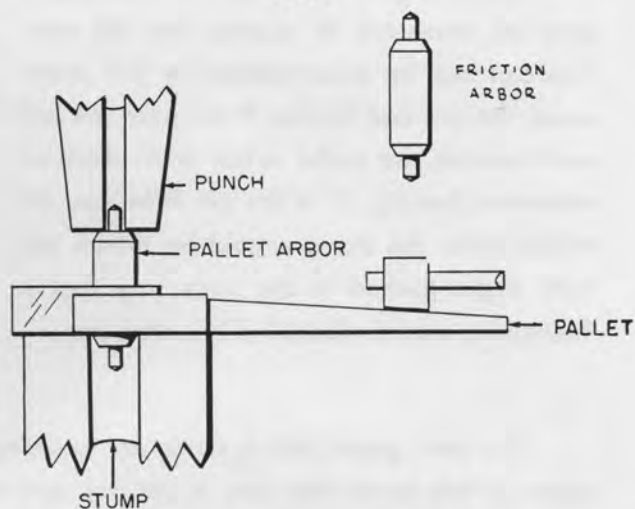
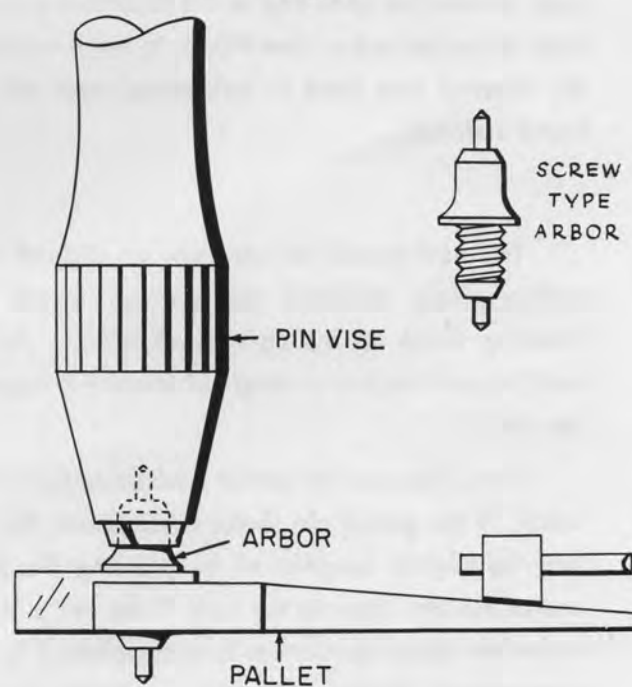
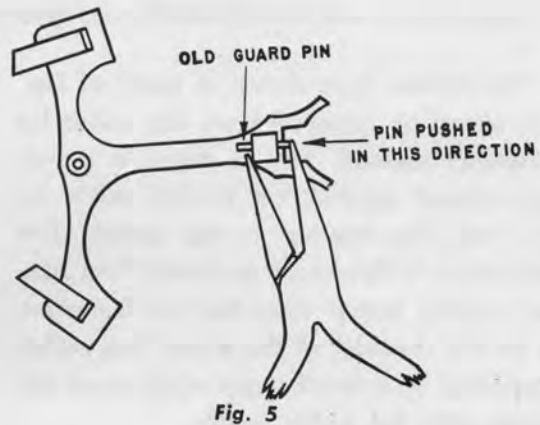

Fig. 4



### No. 3: HOW TO FIT A NEW GUARD PIN

Before a guard pin can be replaced, it may be necessary to remove the old one. This can best be accomplished by first shortening the pin and forcing it out from the tail end towards the pallet arbor with pliers or tweezers. See Fig. 5. If the pin is broken off at the hole, the stump should be driven out with a pin pushed in the same way that a hairspring stud is cleared of the stud pin.



The new guard pin is made by inserting a piece of thin brass wire into a pin vise and roll-filing it on a box-wood slip to a fine taper. After burnishing, the wire is forced friction tight into the hole, so that the small end of the taper pin is away from the pallet arbor. See Fig. 6. In small watches, the tapered pins used in hairspring work will be found suitable.

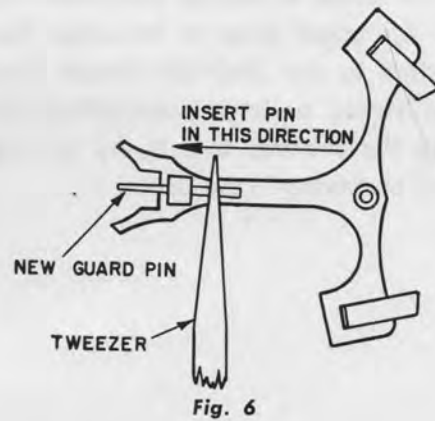

The new guard pin can now be clipped with cutting pliers, allowing just enough length for finishing. Finish off the tip with an oilstone slip, so that the point makes an angle of about 90 degrees. See Fig. 7.

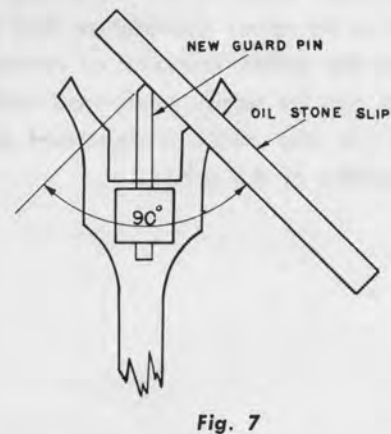

From here on, the pallet must be tested in the watch. If the guard pin shake is excessive, the pin may be slightly lengthened by pressing the thick end of the pin closer to the fork. If the pin is found to be too long, shortening is accomplished in the same way as finishing, by using an oilstone slip.





#### No. 4: HOW TO STRAIGHTEN THE PALLET LEVER

Frequently, a watch that has been improperly repaired will come in with the pallet bent out of the level to accommodate a poor fitting staff. When a genuine or proper fitting staff has been replaced in the watch, it will then be necessary to bend the pallet again back to its original form.

In a case such as this, the pallet should be supported on a boxwood slip or on the wooden handle of a brush so that the pallet arbor is within a small hole already prepared in the wood.

The pallet can now be stroked with tweezers as shown in Fig. 8 until the bent shank is returned to its original level condition.

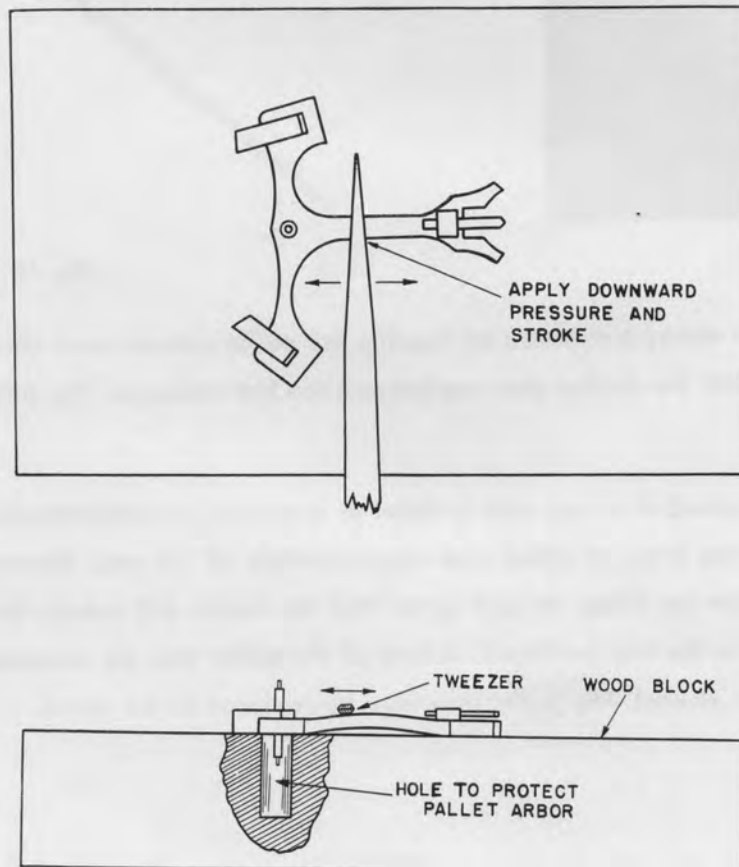
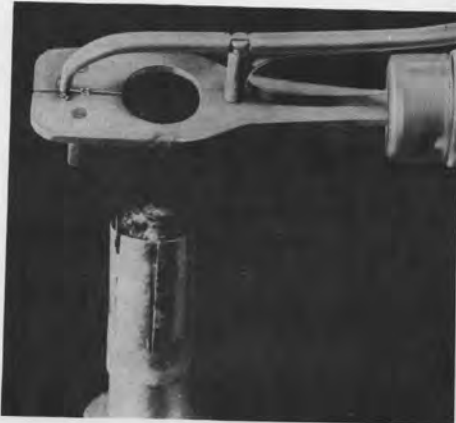

Fig. 8



### **No. 5: HOW TO MOVE PALLET STONES**

In order to move a pallet stone, the pallet must be removed from the watch and placed upside down on a pallet warmer, with the lower pivot placed in the hole provided in the movable arm.



*Fig. 9*



*Fig. 10*

The shellac holding the pallet stones is softened by heating the pallet warmer over an alcohol lamp. See Fig. 9. Care must be taken that the shellac does not become too hot and spoil. The pallet warmer is now removed from the lamp.

One or both stones may be moved in or out with a nickel or brass tool. (A convenient shape is shown in Fig. 10 and may be made from brass or nickel wire approximately of  $1\frac{1}{2}$  mm. diameter.) The pallet is then removed from the warmer by lifting straight up so that the stones will remain level with the body of the pallet. Excess shellac on the top (polished) surface of the pallet may be removed with a piece of pegwood or a buff dipped in alcohol. The pallet may now be replaced in the watch.



### THE PRINCIPLES OF MOVING PALLET STONES

When a pallet stone is moved out (towards the escape wheel tooth), this will cause the pallet fork to swing a greater distance from the line of centers before the lock occurs on the opposite stone.

When the pallet stone is moved in (away from the escape wheel tooth), this fork angle (the distance the pallet swings from the line of centers before locking with the other stone) is reduced.

Because the movement of a pallet stone affects the distance that the pallet will move, it can be stated that if one stone is moved out or in (causing the lock to be increased or decreased), the lock on the opposite stone will be increased or decreased by the same amount.

Let us suppose that the R stone has been pulled out a small amount. Careful inspection of the escapement will show that because the pallet now swings farther from the line of centers before locking on the L stone, that:

1. The lock has been increased the same amount on the L stone.
2. The pallet has moved closer to the L banking pin at the instant of lock, thereby permitting less slide. (See Fig. 11.)

#### R STONE MOVED OUT — L STONE OK

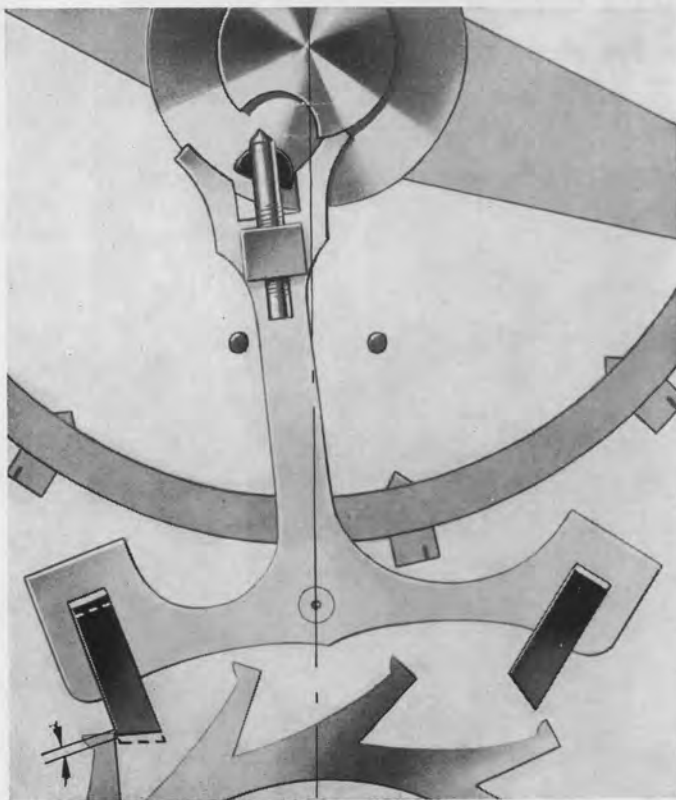

A

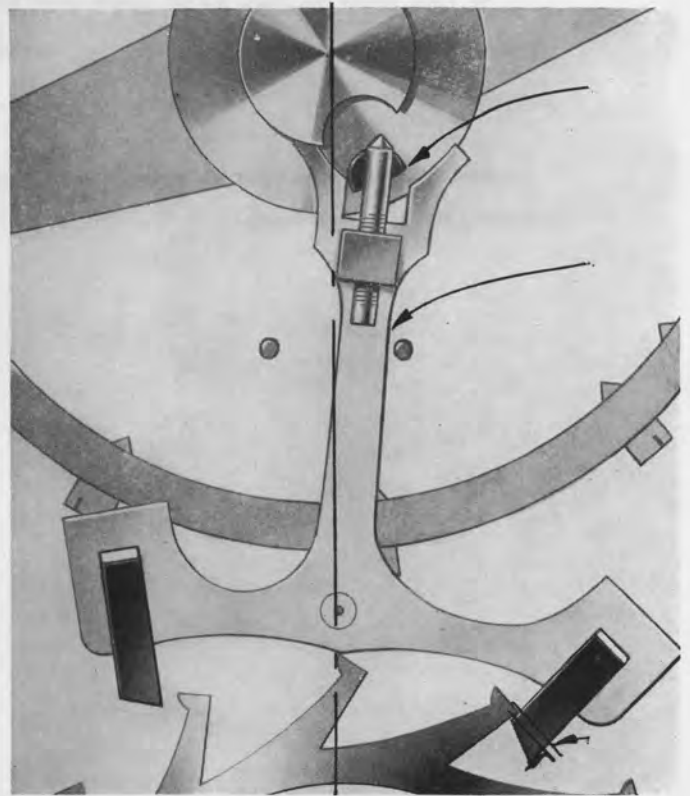

B

Fig. 11



## *Training Unit Number 10a*

Basically, this is the key to what takes place if either stone or both stones should be shifted in any way. Had the R stone been pushed in, so that the pallet now would swing a shorter distance from the line of centers to the point of drop, the lock would have been decreased an equal amount on the L stone and the slide would now be greater on the L stone side. If in place of the R stone, the L stone had been moved, the same conditions would have resulted on the R side.

With the balance wheel in the watch, the amount of travel of the pallet from the line of centers can be determined by trying jewel pin shake. If the pallet is farther away from the line of centers at the instant of lock, then the jewel pin shake will be greater. If the pallet is closer to the line of centers, then the jewel pin shake will be less.

### **PALLET STONE RULE**

**If the lock is too light, pull out the stone opposite the LESSER jewel pin shake. If the lock is too strong, push in the stone opposite the GREATER jewel pin shake.**

Remember this simple procedure and you master every situation involving the movement of pallet stones.



# CHECKS YOU MUST MAKE ON EVERY ESCAPEMENT TO ASSURE MINIMUM SAFE FUNCTIONING IN A WATCH



1

## CHECK JEWEL PIN FREEDOM IN FORK SLOT

Take off all power and allow balance to move to center position. Jewel pin will be approximately on line of centers. Hold balance in this position with finger and shake pallet to observe shake between fork slot and jewel pin. There must be some freedom but not enough to cause significant lost motion between fork and jewel pin at impulse. See Fig. 1.

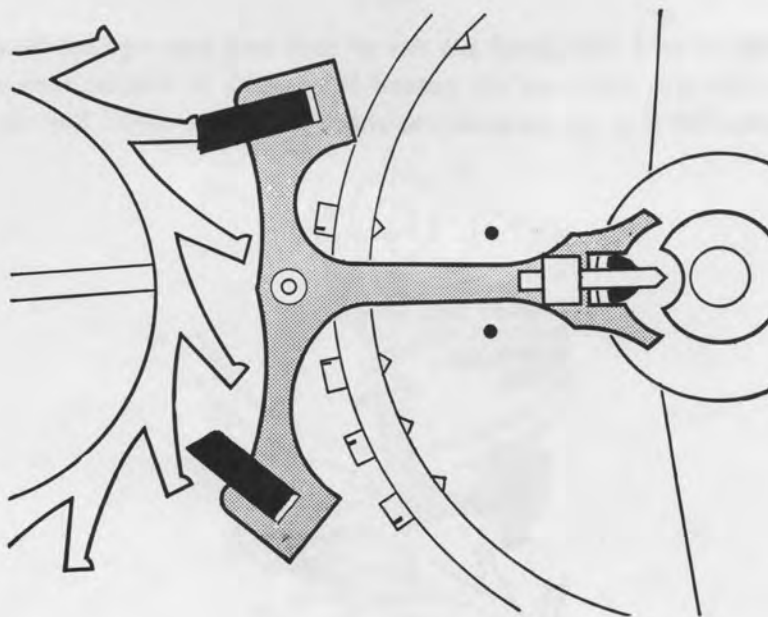

Fig. 1





# 2

## CHECK LOCK AND SLIDE

With some power on train, move balance to exact instant of drop and hold carefully at this point. Note whether lock is safe. Observe whether there is any slide by noting whether there is any clearance between fork and nearest banking pin. Repeat these checks for minimum lock and slide on both stones and for one revolution of the escape wheel. See Fig. 2.

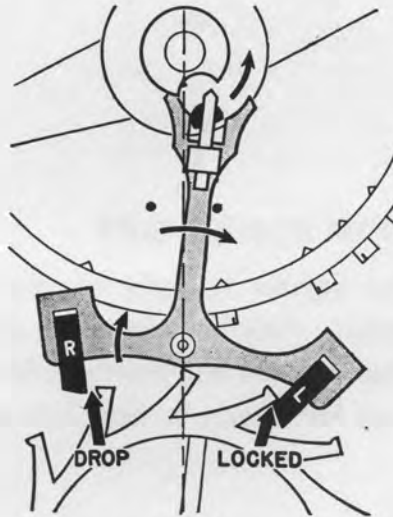

Fig. 2

With balance wheel held with jewel pin out of fork and fork against banking pin, note lock plus slide. Lock plus slide may not exceed  $\frac{1}{3}$  of width of impulse face of pallet stone. Check both stones, but it is not necessary to check all escape teeth. See Fig. 3.

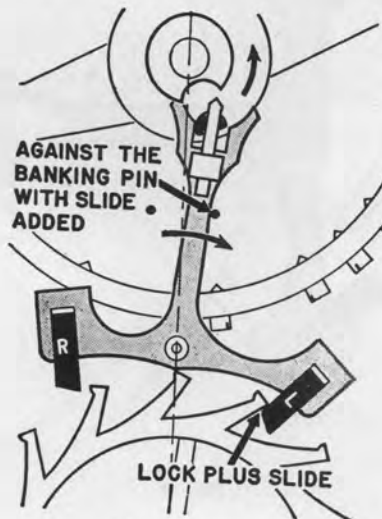

Fig. 3



### 3

#### CHECK JEWEL PIN CLEARANCE

With some power on the train, hold pallet against banking pin and allow balance wheel to turn under hairspring action until jewel pin lies against inside side of fork slot. Hold balance carefully in this position and note shake of pallet between jewel pin and banking pin. With pallet pushed against the jewel pin, lock must remain safe. Also, there must be some shake of fork between banking pin and jewel pin. See Fig. 4.

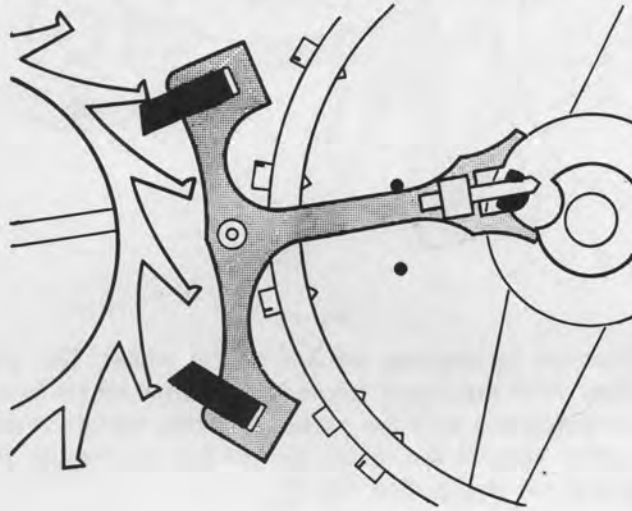

Fig. 4

Move balance slightly in a direction to disengage jewel pin from fork and repeat check for minimum and maximum jewel pin clearance. Repeat until jewel pin no longer lies within fork horn. Repeat check on opposite side. In cases where lock is barely safe with fork horn against jewel pin in above check, it is well to repeat test on all teeth, particularly if escape wheel teeth are not all of equal length as found in test Number 2. See Fig. 5.

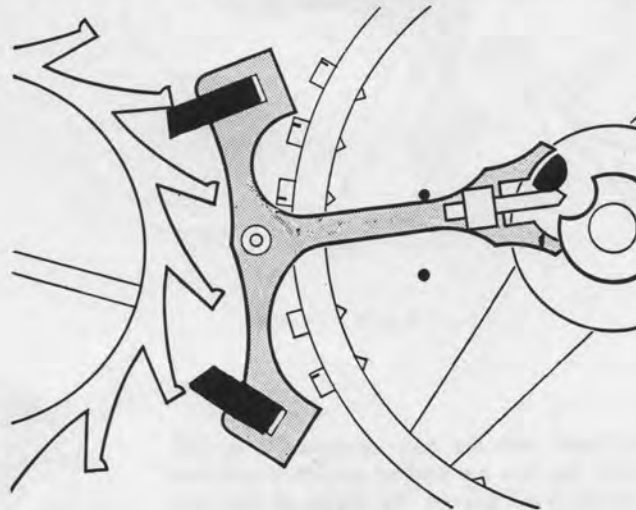

Fig. 5



**CHECK GUARD PIN SHAKE**

Check shake of fork between banking pin and safety roller for a number of positions of the balance wheel, beginning at balance wheel position where the jewel pin has just left the fork horn. There must be guard pin shake for all positions of the balance wheel. Repeat check with escape wheel locked on other pallet stone. See Fig. 6.

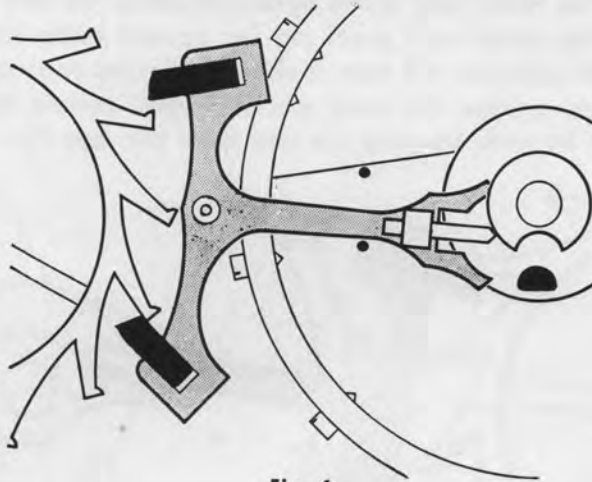

Fig. 6

Now reverse train direction by pushing on 3rd or 4th wheel. This pushes the guard pin against the safety roller. With the finger rotate the balance wheel back and forth to bring the roller jewel into engagement with the pallet, to make certain it does not catch on the tip of fork horn on either side. If the jewel pin catches on the tip of the fork horn, this indicates excessive guard pin shake. See Fig. 7.

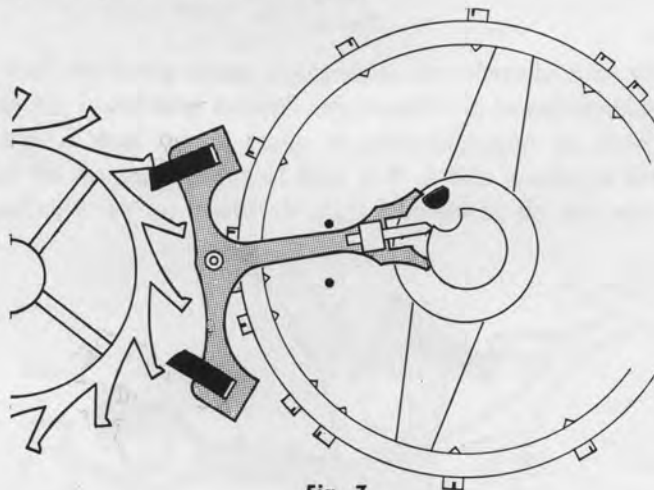

Fig. 7

.....

NOTE—While making this check with the train reversed, it is well to make sure that the jewel pin can be pushed smoothly into the fork slot. Any catching of the jewel pin on the inside of the fork horns is an indication of roughness or burrs on this portion of the pallet. See Fig. 8.

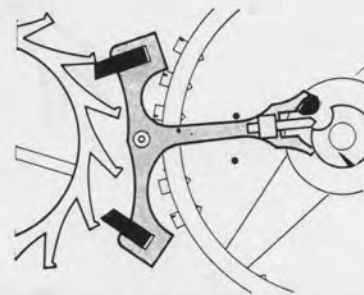

Fig. 8