

Characteristics

Casing dimension: 15.15×13.00 mm  
 Maximum height: 4.30 mm  
 Vibrations per hour: 21,600  
 Non-automatic with sweep second  
 "Diashock" Shock Resistant Device

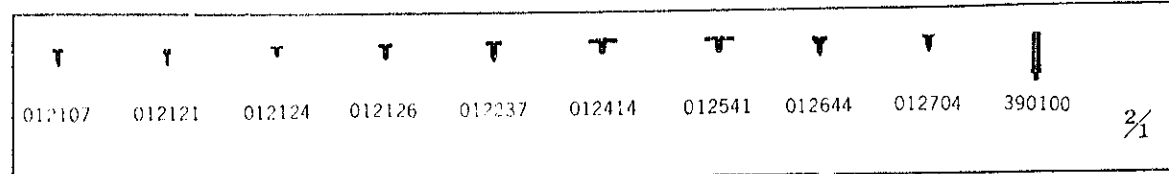

Cal. 1104A

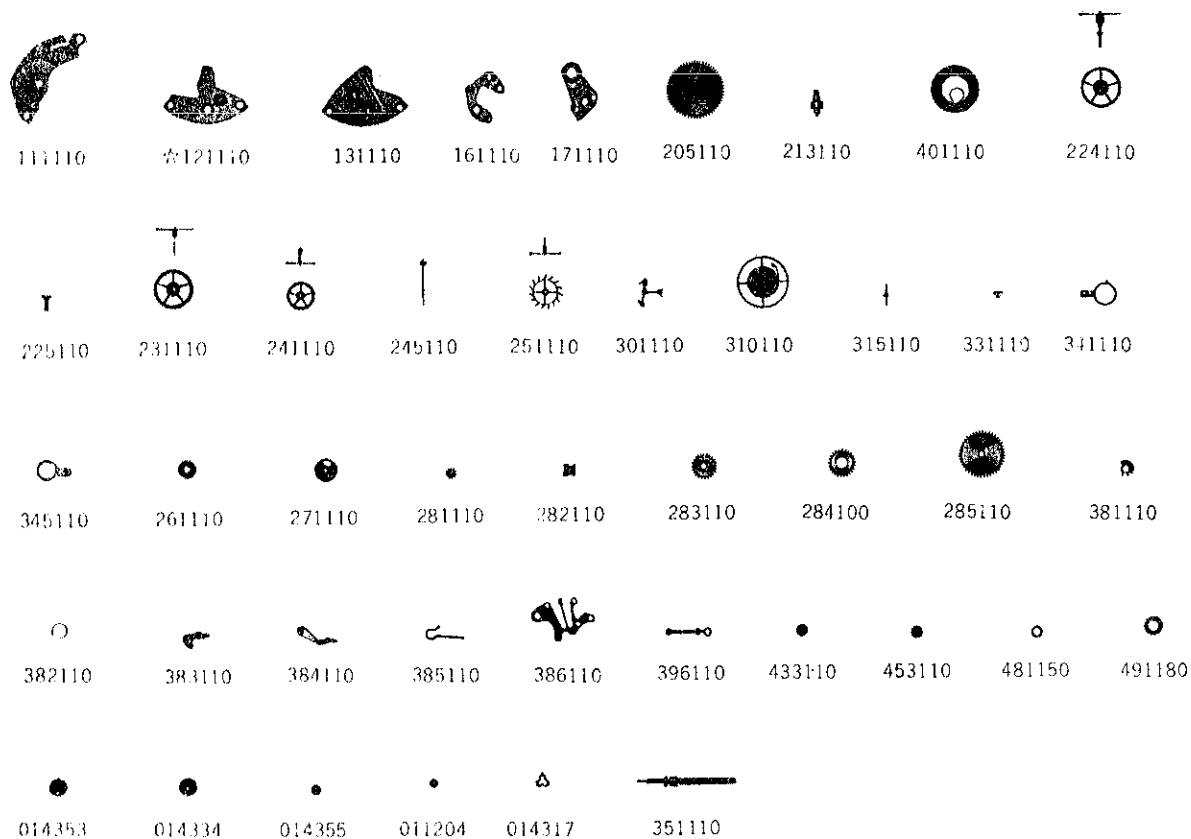

Calibre No.		Jewels	Style Name	
<b>1104A</b>		<b>17j</b>		
PART NO.	LIST OF MATERIALS	PART NO.	LIST OF MATERIALS	
111110	Barrel bridge	012121	Stud screw	
☆121110	Train-wheel bridge	012124	Friction spring screw for sweep second pinion	
131110	Third wheel bridge	012126	Pallet cock screw	
161110	Pallet cock	012237	Bridge screw	
171110	Balance cock	012237	Third wheel bridge screw	
205110	Complete barrel with arbor	012237	Balance cock screw	
213110	Barrel arbor	012414	Ratchet wheel screw	
224110	Center wheel & pinion with cannon pinion	012541	Crown wheel screw	
225110	Cannon pinion	012644	Click screw	
231110	Third wheel & pinion	012704	Setting lever spring screw	
241110	Fourth wheel & pinion	011521	Upper hole jewel for center wheel	
245110	Sweep second pinion	011150	Lower hole jewel for center wheel	
251110	Escape wheel & pinion	011523	Lower hole jewel for 3rd wheel	
261110	Minute wheel	011713	Lower hole jewel for sweep second pinion	
271110	Hour wheel	011505	Lower hole jewel for escape wheel	
281110	Setting wheel	011505	Upper hole jewel for pallet	
282110	Clutch wheel	011505	Lower hole jewel for pallet	
283110	Winding pinion	013106	Tube for pallet cock screw	
284100	Crown wheel	013112	Tube for bridge screw, short	
285110	Ratchet wheel	013172	Tube for bridge screw, long	
301110	Jewelled pallet fork & staff			
310110	Balance complete with stud			
315110	Balance staff			
331110	Roller with jewel			
341110	Regulator			
345110	Stud holder			
351110	Winding stem			
381110	Click			
382110	Click spring			
383110	Setting lever			
384110	Yoke (Clutch lever)			
385110	Yoke spring (Clutch lever spring)			
386110	Setting lever spring (Set bridge)			
390100	Setting lever axle			
396110	Friction spring for sweep second pinion			
401110	Main spring (self-greasing)			
433110	Upper hole jewel with frame for 3rd wheel			
433110	Upper hole jewel with frame for 4th wheel			
453110	Upper hole jewel with frame for escape wheel			
481150	Crown wheel ring			
491180	Dial washer			
014353	Diashock upper frame			
014334	Diashock lower frame			
014355	Diashock hole jewel with frame			
011204	Diashock cap jewel			
014317	Diashock spring			
012107	Dial screw			

Remarks :

Train-wheel bridge

☆121110.....Two different shapes in the same part number (interchangeable).



☆⇒ Please see remarks on the reverse page.

☆⇒ Please see remarks.  
 Items in light letters are not shown in photos.

(Revised)

Calibre No.	<b>1104A</b>	Jewels	<b>21j</b>	Style Name	
⇒ Basic Calibre 1104A 17J Catalog No. 11-04-1					



Col. 1104A

**Characteristics**

Casing dimension: 15.15×13.00 mm  
 Maximum height: 4.30 mm  
 Vibrations per hour: 21,600  
 Non-automatic with sweep second  
 "Diashock" Shock Resistant Device  
 "Diafix" Oil Lubrication Device

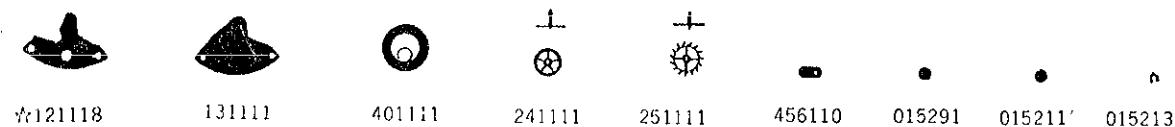

☆121118 131111 401111 241111 251111 456110 015291 015211 015213

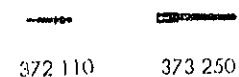

372 110 373 250

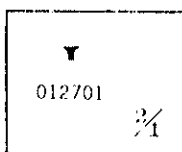

Catalog No. 11-04-2

Calibre No.	<b>1104A</b>	Jewels	<b>21j</b>	Style Name	
⇒ Basic Calibre 1104A 17J Catalog No. 11-04-1					

PART NO.	PART NAME	PART NO.	PART NAME
111110	Barrel bridge	012107	Dial screw
☆121118	Train-wheel bridge	012121	Stud screw
131111	Third wheel bridge	012124	Friction spring screw for sweep second pinion
161110	Pallet cock		Pallet cock screw
171110	Balance cock	012126	Bridge screw
205110	Complete barrel with arbor	012237	Third wheel bridge screw
213110	Barrel arbor	012237	Balance cock screw
224110	Center wheel & pinion with cannon pinion	012237	Ratchet wheel screw
225110	Cannon pinion	012414	Crown wheel screw
231110	Third wheel & pinion	012541	Click screw
241111	Fourth wheel & pinion	012644	Lower end-piece screw for escape wheel
245110	Sweep second pinion		Setting lever spring screw
251111	Escape wheel & pinion	012704	Upper hole jewel for center wheel
261110	Minute wheel	011521	Lower hole jewel for center wheel
271110	Hour wheel	011150	Lower hole jewel for 3rd wheel
281110	Setting wheel	011523	Lower hole jewel for 4th wheel
282110	Clutch wheel	011528	Lower hole jewel for sweep second pinion
283110	Winding pinion	011713	Lower hole jewel for escape wheel
284100	Crown wheel	011608	Upper hole jewel for pallet
285110	Ratchet wheel	011505	Lower hole jewel for pallet
301110	Jewelled pallet fork & staff	013106	Tube for pallet cock screw
310110	Balance complete with stud	013112	Tube for bridge screw, short
315110	Balance staff	013172	Tube for bridge screw, long
331110	Roller with jewel		
341110	Regulator		
345110	Stud holder		
351110	Winding stem		
372110	Joint stem (movement portion)		
373250	Joint stem (case portion)		
381110	Click		
382110	Click spring		
383110	Setting lever		
384110	Yoke (Clutch lever)		
385110	Yoke spring (Clutch lever spring)		
386110	Setting lever spring (Set bridge)		
390100	Setting lever axle		
396110	Friction spring for sweep second pinion		
401111	Mainspring (self-greasing)		
433110	Upper hole jewel with frame for 3rd wheel		
456110	Lower end-piece for escape wheel		
481150	Crown wheel ring		
491180	Dial washer		
014353	Diashock upper frame		
014334	Diashock lower frame		
014355	Diashock hole jewel with frame		
011204	Diashock cap jewel		
014317	Diashock spring		
015291	Diafix upper hole jewel with frame for 4th wheel		
015211	Diafix upper hole jewel with frame for escape wheel		
011204	Diafix cap jewel		
015213	Diafix spring		

**Remarks :**

Train-wheel bridge

☆121118.....Two different shapes in the same part number (interchangeable).



☆⇒ Please see remarks on the reverse page.

As for all other parts not shown here, please refer to the basic calibre (Cal. No. 1104A 17J Catalog No. 11-04-1 Red page).

☆⇒ Please see remarks.

Items in light letters are not shown in photos; those parts are interchangeable with the basic calibre

(Cal. No. 1104A 17J Catalog No. 11-04-1 Red page).

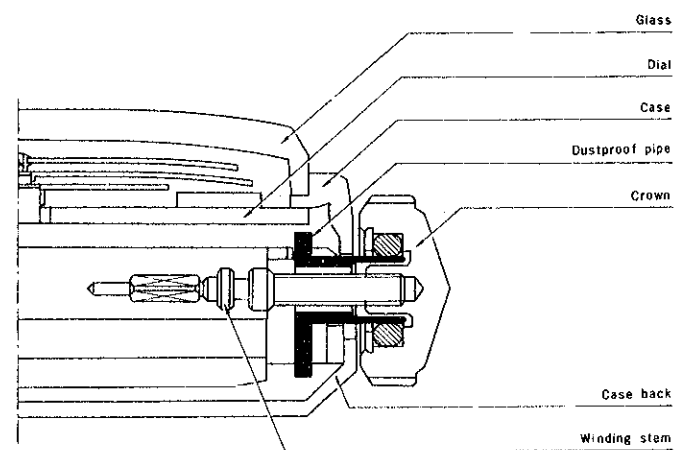

Fig. 1

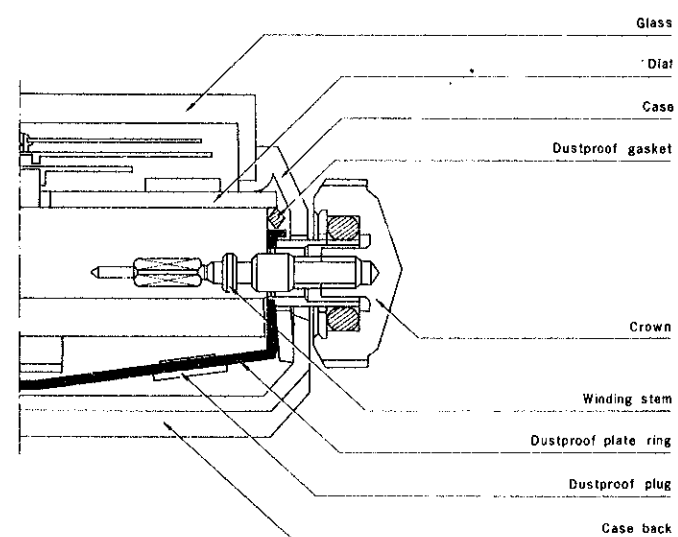

Fig. 2

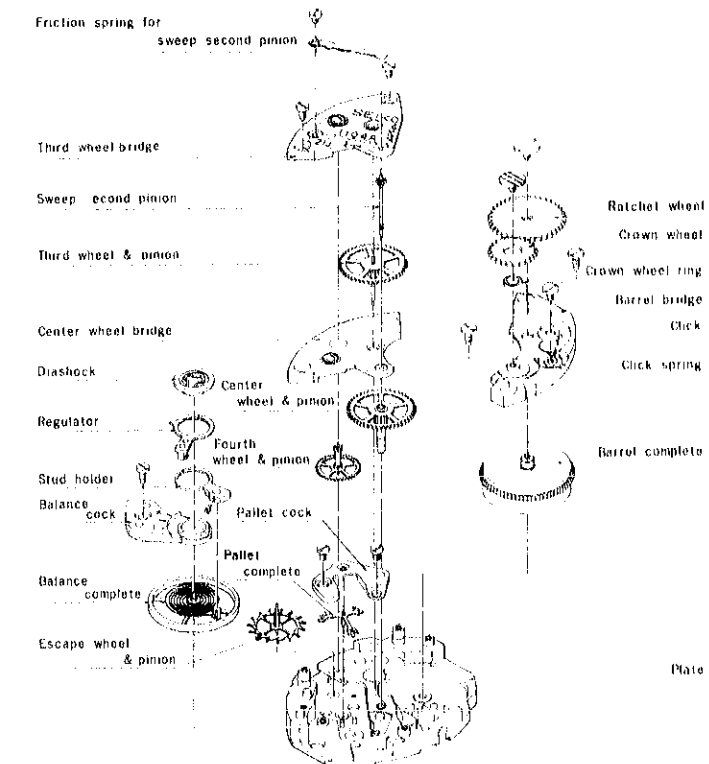

Fig. 3

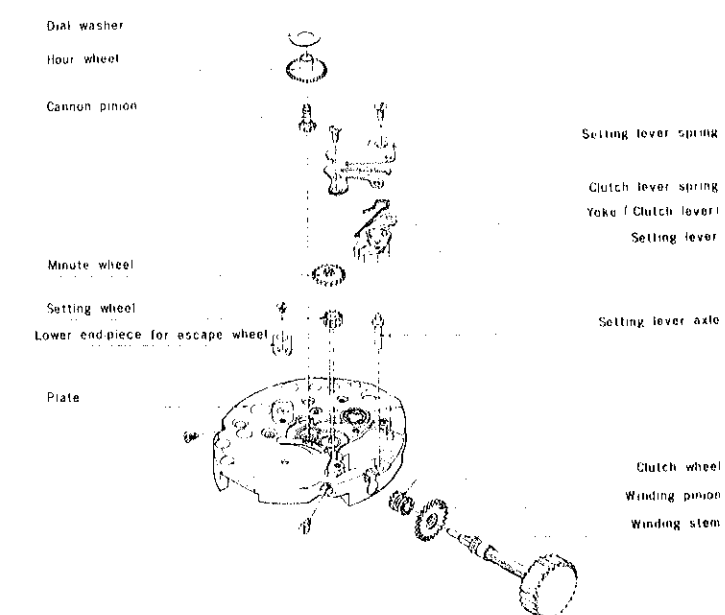
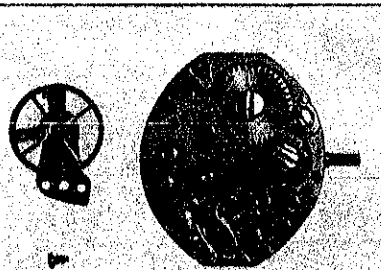
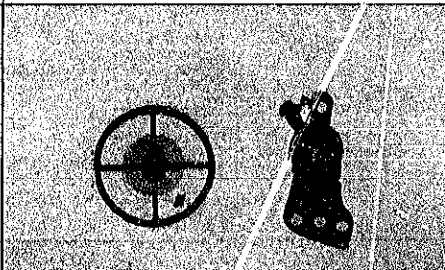
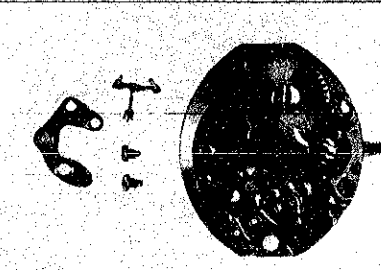
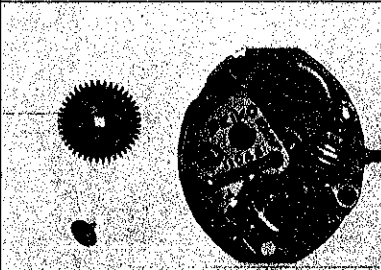
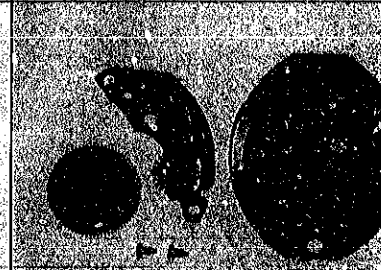

Fig. 4

## 1104A Disassembly and assembly—continued

## 1104A Disassembly and assembly—continued

Disassembly	<b>1</b>	<b>BALANCE COCK</b>	<b>2</b>	<b>BALANCE</b>	<b>3</b>	<b>UNWINDING OF MAINSPRING</b>
	<ol style="list-style-type: none"> <li>1) Remove balance cock screw</li> <li>2) Remove balance cock</li> </ol>		<ol style="list-style-type: none"> <li>1) Turn regulator key with screwdriver and then remove spring</li> <li>2) Loosen stud screw</li> <li>3) Remove stud from balance cock</li> </ol>		<p>Disengage click and ratchet wheel from gearing, with tweezers, and slowly unwind the spring</p>	
	Be careful not to bend hair spring					
Photo						
Assembly	<b>18</b>	<b>BALANCE COCK</b>	<b>17</b>	<b>BALANCE</b>	<b>16</b>	<b>ROTATION OF HANDS</b>
	<ol style="list-style-type: none"> <li>1) Set balance cock with balance</li> <li>2) Fasten balance cock screw</li> <li>3) Check proper end shake of balance</li> </ol>		<ol style="list-style-type: none"> <li>1) Set balance on balance cock</li> <li>2) Turn regulator key, so that hair spring is held</li> <li>3) Fasten stud screw, so that stud head is kept above balance cock (in proper position)</li> </ol>		<ol style="list-style-type: none"> <li>1) Check the rotation of hands</li> <li>2) Check end shake of pallet</li> </ol>	
			Carefully check centering of hair spring			
Remark						

Disassembly	<b>4</b>	<b>PALLET</b>	<b>5</b>	<b>RATCHET WHEEL</b>	<b>6</b>	<b>BARREL COMPLETE WITH ARBOR</b>
	<ol style="list-style-type: none"> <li>1) Remove pallet cock screws (2 pcs)</li> <li>2) Remove pallet cock</li> <li>3) Remove pallet</li> </ol>		<ol style="list-style-type: none"> <li>1) Remove ratchet wheel screw</li> <li>2) Remove ratchet wheel</li> </ol>		<ol style="list-style-type: none"> <li>1) Remove barrel bridge screws (2 pcs)</li> <li>2) Remove barrel complete with arbor</li> </ol>	
					As barrel is removed, be careful not to touch center wheel, and third wheel.	
Photo						
Assembly	<b>15</b>	<b>PALLET</b>	<b>14</b>	<b>RATCHET WHEEL</b>	<b>13</b>	<b>BARREL COMPLETE</b>
	<ol style="list-style-type: none"> <li>1) Lubricate pallet jewels (Moebius Synt-A-Lube)</li> <li>2) Set pallet</li> <li>3) Set pallet cock</li> <li>4) Fasten pallet cock screws (2 pcs)</li> </ol>		<ol style="list-style-type: none"> <li>1) Set ratchet wheel</li> <li>2) Fasten ratchet wheel screw</li> <li>3) Check revolving condition of train wheels</li> </ol>		<ol style="list-style-type: none"> <li>1) Lubricate upper and lower pivots of barrel complete with arbor (watch oil S-4 or Moebius grease "Remontoires")</li> <li>2) Set barrel complete with arbor</li> <li>3) Set barrel bridge</li> <li>4) Fasten barrel bridge screws (2 pcs)</li> </ol>	
	Check that pallet pivots has been put in jewel holes, and then fasten bridge screw.					
Remark						

# 1104A Disassembly and assembly—continued



# 1104A Disassembly and assembly—continued

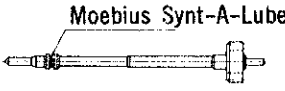

	7 CROWN WHEEL	8 CLICK AND CLICK SPRING	9 FRICTION SPRING FOR SWEEP SECOND PINION
Disassembly Method	<ol style="list-style-type: none"> <li>1) Remove crown wheel screw</li> <li>2) Remove crown wheel</li> <li>3) Remove crown wheel ring</li> </ol>	<ol style="list-style-type: none"> <li>1) Remove click screw</li> <li>2) Remove click</li> <li>3) Remove click spring</li> </ol>	<ol style="list-style-type: none"> <li>1) Remove friction spring screw for sweep second pinion</li> <li>2) Remove friction spring for sweep second pinion</li> </ol>
Disassembly Remark	Note that only crown wheel screw is left-threaded.		Be careful not to deform friction spring for sweep second pinion.
Photo			
	12 CROWN WHEEL	11 CLICK AND CLICK SPRING	10 CANNON PINION
Assembly Method	<ol style="list-style-type: none"> <li>1) Set crown wheel ring on the barrel bridge</li> <li>2) Lubricate side of crown wheel ring (watch oil S-4 or Moebius grease "Remontoires")</li> <li>3) Set crown wheel</li> <li>4) Fasten crown wheel screw</li> </ol>	<ol style="list-style-type: none"> <li>1) Set click spring to the barrel bridge</li> <li>2) Set click to the barrel bridge</li> <li>3) Fasten click screw</li> </ol>	<ol style="list-style-type: none"> <li>1) Lubricate lower pivot of center wheel and pinion (watch oil S-4 or Moebius grease "Remontoires")</li> <li>2) Set cannon pinion</li> </ol>
Assembly Remark	Note: Three grooved screw means left thread screw.	Be careful that the click spring does not leap off	

	10 THIRD WHEEL BRIDGE	11 SWEEP SECOND PINION THIRD WHEEL AND PINION	12 CENTER WHEEL BRIDGE
Disassembly Method	<ol style="list-style-type: none"> <li>1) Remove third wheel bridge screws (2 pcs)</li> <li>2) Remove third wheel bridge</li> </ol>	<ol style="list-style-type: none"> <li>1) Remove sweep second pinion</li> <li>2) Remove third wheel and pinion</li> </ol>	<ol style="list-style-type: none"> <li>1) Remove center wheel bridge</li> </ol>
Disassembly Remark			
Photo			
	9 THIRD WHEEL BRIDGE	8 SWEEP SECOND PINION THIRD WHEEL AND PINION	7 CENTER WHEEL BRIDGE
Assembly Method	<ol style="list-style-type: none"> <li>1) Set third wheel bridge and screws (2 pcs)</li> <li>2) Make sure that train wheels rotate smoothly and check end shake of each wheel and pinion</li> <li>3) Lubricate upper pivot of third wheel and pinion (watch oil S-4)</li> <li>4) Lubricate upper pivot of sweep second pinion (Moebius Synt-A-Lube)</li> <li>5) Set friction spring for sweep second pinion and fasten screw</li> </ol>	<ol style="list-style-type: none"> <li>1) Set third wheel</li> <li>2) Lubricate sweep second pinion and set it</li> </ol>	<ol style="list-style-type: none"> <li>1) Lubricate upper pivot of center wheel and pinion (watch oil S-4 or Moebius grease "Remontoires")</li> <li>2) Set center wheel bridge</li> </ol>
Assembly Remark	<p>Since its construction is purposely thin, pay attention to the friction spring for sweep second pinion to prevent warping, bending, breaking, and so on. Correctly install the friction spring for sweep second pinion on the recessed part of third wheel bridge; rounded center portion should be on the bottom of the recess.</p> 		

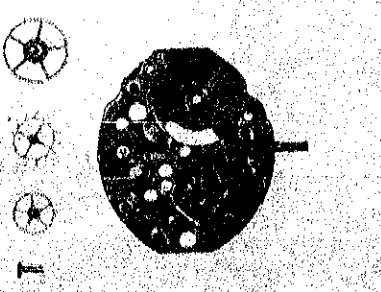
1104A Disassembly and assembly—continued

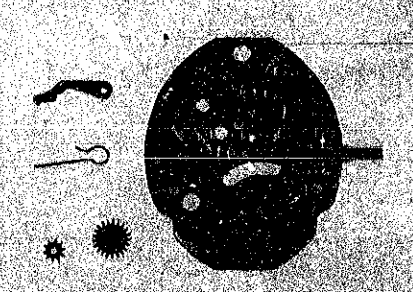
1104A Disassembly and assembly—continued

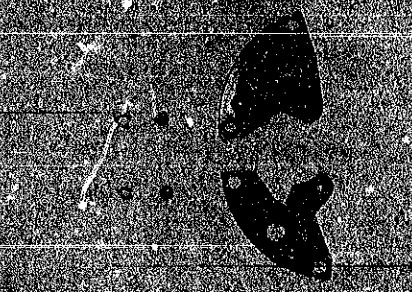
Disassembly	<b>13</b>	<b>CENTER WHEEL AND PINION FOURTH WHEEL AND PINION</b>	<b>14</b>	<b>SETTING LEVER SPRING</b>	<b>15</b>	<b>MINUTE WHEEL, SETTING WHEEL AND CLUTCH LEVER</b>
	<ol style="list-style-type: none"> <li>1) Remove fourth wheel and pinion</li> <li>2) Remove cannon pinion</li> <li>3) Remove center wheel and pinion</li> </ol>		<ol style="list-style-type: none"> <li>1) Remove screws for setting lever spring (2 pcs)</li> <li>2) Remove setting lever spring</li> <li>3) Remove lower end-piece screw for escape wheel</li> <li>4) Remove lower end-piece for escape wheel</li> </ol>		<ol style="list-style-type: none"> <li>1) Remove minute wheel</li> <li>2) Remove setting wheel</li> <li>3) Remove clutch lever spring</li> <li>4) Remove clutch lever</li> </ol>	
	Take out the cannon pinion vertically					
Photo						
Assembly	<b>6</b>	<b>CENTER WHEEL AND PINION, FOURTH WHEEL AND PINION, &amp; ESCAPE WHEEL AND PINION</b>	<b>5</b>	<b>SETTING LEVER SPRING</b>	<b>4</b>	<b>MINUTE WHEEL, SETTING WHEEL AND CLUTCH LEVER</b>
	<ol style="list-style-type: none"> <li>1) Lubricate center lower jewel (watch oil S-4)</li> <li>2) Set center wheel and pinion</li> <li>3) Lubricate lower end-piece for escape wheel, and lower hole jewel of fourth wheel</li> <li>4) Lubricate lower hole jewel of third wheel (watch oil S-4)</li> <li>5) Set escape wheel, fourth wheel</li> </ol>		<ol style="list-style-type: none"> <li>1) Set setting lever spring and fasten screws (2 pcs)</li> <li>2) Set lower end-piece for escape wheel and fasten screw</li> </ol>		<ol style="list-style-type: none"> <li>1) Set clutch lever and its spring</li> <li>2) Lubricate minute wheel pivot, and setting wheel pin (watch oil S-4)</li> <li>3) Set setting wheel and minute wheel</li> </ol>	
			First fasten the screw on side of winding wheel.			
Remark						

Disassembly	<b>16</b>	<b>WINDING STEM</b>	<b>17</b>	<b>DIAFIX</b>	<b>18</b>	<b>DIASHOCK</b>
	<ol style="list-style-type: none"> <li>1) Remove setting lever</li> <li>2) Remove setting lever axle</li> <li>3) Remove winding stem</li> <li>4) Remove clutch wheel, winding pinion</li> </ol>		<ol style="list-style-type: none"> <li>1) Remove Diafix spring</li> <li>2) Remove cap jewel</li> </ol>		<ol style="list-style-type: none"> <li>1) Remove Diashock springs</li> <li>2) Remove cap jewel</li> <li>3) Remove hole jewel with frame</li> </ol>	
Photo						
Assembly	<b>3</b>	<b>WINDING STEM</b>	<b>2</b>	<b>DIAFIX</b>	<b>1</b>	<b>DIASHOCK</b>
	<ol style="list-style-type: none"> <li>1) Set winding pinion, clutch wheel</li> <li>2) Lubricate winding stem and set it</li> <li>3) Set setting lever axle, setting lever</li> <li>4) Lubricate winding pinion and clutch wheel</li> <li>5) Lubricate setting lever end, setting lever dowel</li> </ol>		<ol style="list-style-type: none"> <li>1) Set Diafix cap jewel in center wheel bridge and third wheel bridge</li> <li>2) Set spring</li> <li>3) Lubricate it from the other side</li> <li>4) Extent of lubrication: (Moebius Synt-A-Lube) Dia. of cap jewels Max. 1/2 Min. 1/3</li> </ol>		<ol style="list-style-type: none"> <li>1) Place cap jewel with flat surface upward</li> <li>2) Put drop of oil on its center, holding cap jewel with tweezers</li> <li>3) Set Diashock hole jewel with frame directly over oiled cap jewel  (Moebius Synt-A-Lube) Dia. of hole jewel Max. 1/2 Min. 1/3</li> <li>4) Set Diashock frames in the plate and balance cock</li> <li>5) Set Diashock spring</li> </ol>	
	Lubricate them watch oil S-4 or Moebius grease "Remontoires".					
Remark						