

PARTS CATALOGUE/TECHNICAL GUIDE

Cal. 3M62A

[SPECIFICATIONS]

Item		Cal. No.	3M62A
Movement			 <div style="text-align: right;">(x 1.0)</div>
Movement size	Outside diameter		ø24.0 mm
	Casing diameter		ø23.3 mm
	Height		4.2 mm
Time indication			3 hands
Driving system			Step motor (Load compensated driving pulse type)
Additional mechanism			<ul style="list-style-type: none"> • Automatic generating system • Power reserve indicator • Energy depletion forewarning function • Overcharge prevention function • Electronic circuit reset switch • Train wheel setting device • Date calendar • Instant setting device for date calendar
Loss/gain			Monthly rate at normal temperature range: less than 15 seconds
Regulation system			Nil
Measuring gate by quartz tester			Use 10-second gate.
Power supply	Power generator		Automatic generating system
	KINETIC E.S.U.		Titanium lithium ion rechargeable battery
Operating voltage range			0.45 V ~ 2.2 V
Duration of charge			From full charge to stoppage: Approx. 2 months
Jewels			7 jewels

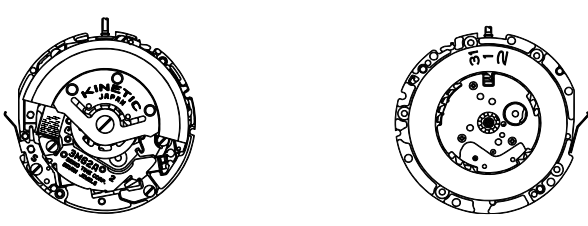

PARTS CATALOGUE

Cal. 3M62A

Disassembling procedures Figs. : ① → ⑤①

Reassembling procedures Figs. : ⑤① → ①

Lubricating: Types of oil



-  Moebius A
-  Moebius F
-  SEIKO Watch Oil S-6

Oil quantity

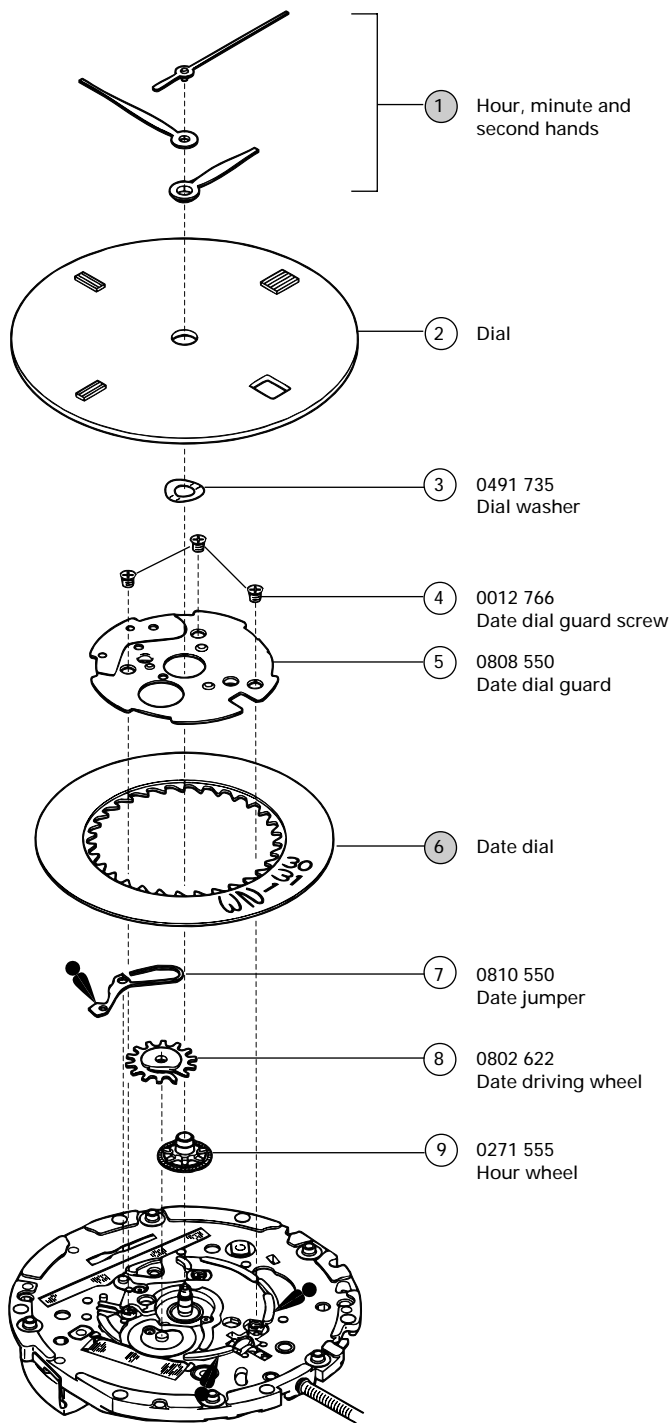
-  Normal quantity

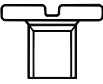
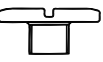



	0012 766 • Date dial guard screw (3 pcs.)
	0012 354 • Rechargeable battery clamp screw (2 pcs.) • Circuit block cover B screw (2 pcs.) • Circuit block cover A screw (3 pcs.) • Oscillating weight bridge screw (2 pcs.) • Plus lead terminal screw (1 pc.) • Setting lever spring screw (1 pc.)
	0022 490 • Oscillating weight screw (1 pc.)

  Please see the remarks on the following pages.
Lubricating of some parts is shown in "II. REMARKS ON DISASSEMBLING AND REASSEMBLING".

PARTS CATALOGUE

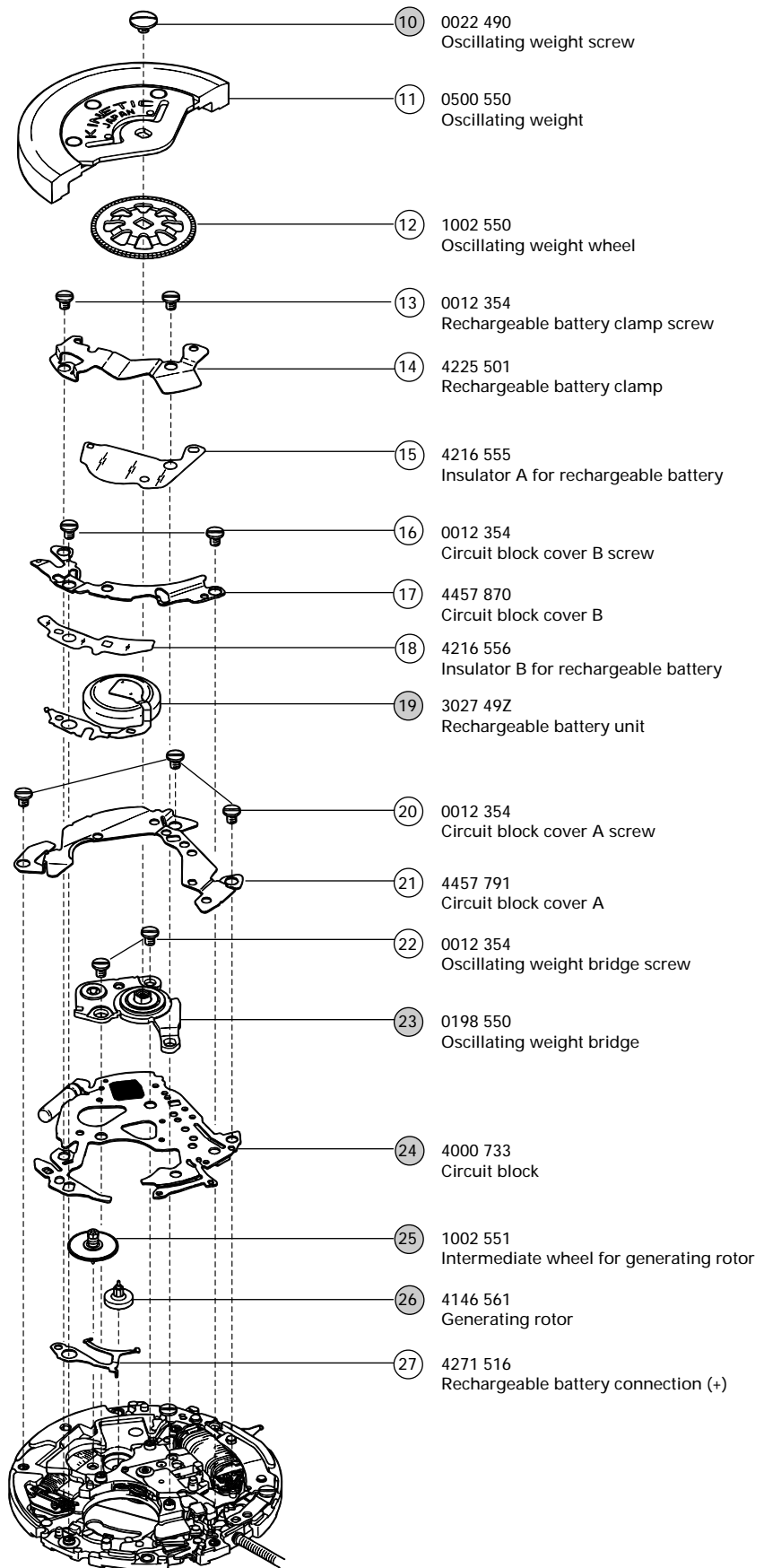
Cal. 3M62A





 Please see the remarks on the following pages.
 Lubricating of some parts is shown in "II. REMARKS ON DISASSEMBLING AND REASSEMBLING".

PARTS CATALOGUE

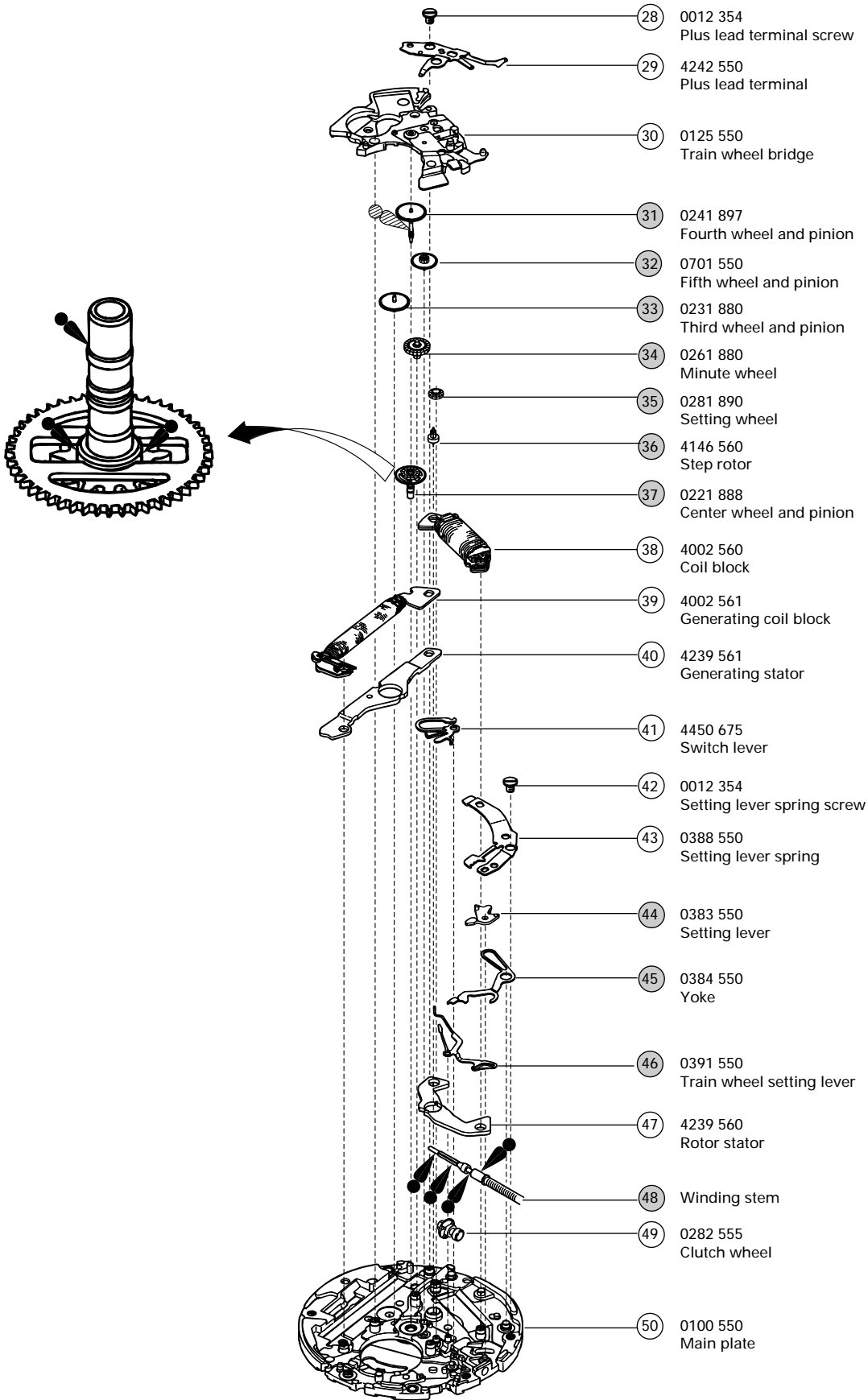
Cal. 3M62A



● → Please see the remarks on the following pages.
 Lubricating of some parts is shown in "II. REMARKS ON DISASSEMBLING AND REASSEMBLING".

Remarks:

⑥ Date dial

Part code	Position of crown	Position of calendar frame	Color of figure	Color of background
0878 699	3 o'clock	3 o'clock	Gold	Black
0878 696	3 o'clock	3 o'clock	Black	White

The type of date dial is determined based on the design of cases.
Check the case number and refer to "SEIKO Casing Parts Catalogue" to choose a corresponding date dial.

④⑧ Winding stem 0351 550

The type of winding stem is determined based on the design of cases.
Check the case number and refer to "SEIKO Casing Parts Catalogue" to choose a corresponding winding stem.

TECHNICAL GUIDE

- The explanation here is only for the particular points of Cal. 3M62A.
- For the repairing, checking and measuring procedures, refer to the "TECHNICAL GUIDE, GENERAL INSTRUCTIONS".

I. STRUCTURE OF THE CIRCUIT BLOCK

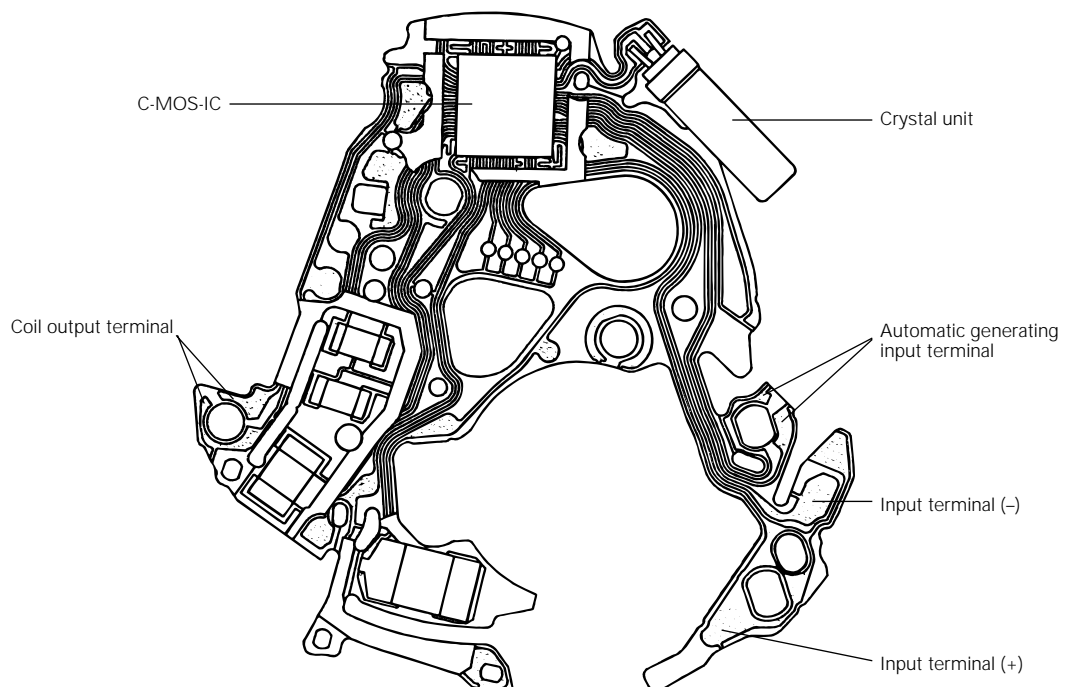

II. REMARKS ON DISASSEMBLING AND REASSEMBLING

For disassembling and reassembling, be sure to use the universal movement holder.

① Hands

Place the movement directly on the riveting plate shown in the illustration with the oscillating weight down, so that the oscillating weight screw is not damaged. Then, press in the hands.

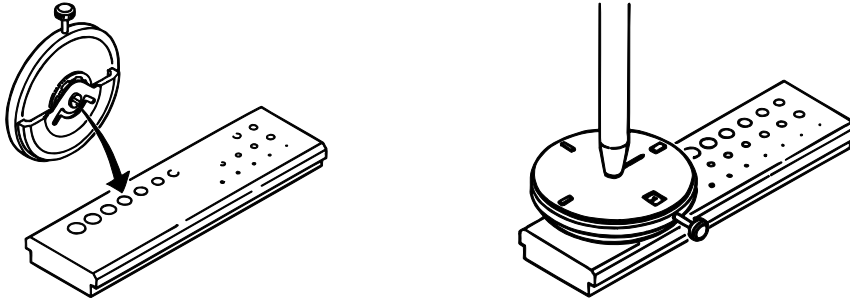

⑩ Oscillating weight screw

Tighten the oscillating weight screw firmly, applying more force than usual.

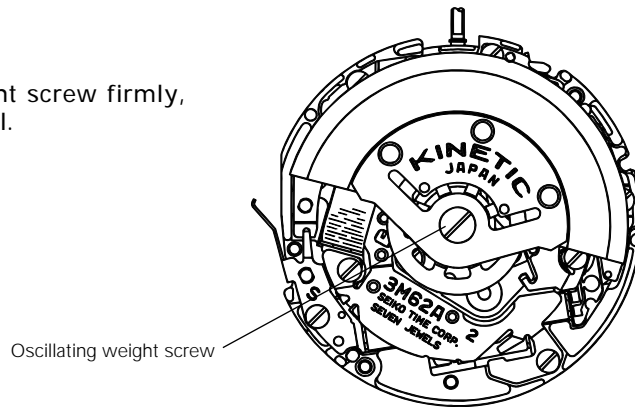

⑲ Rechargeable battery unit

Though they have a close resemblance in shape, the rechargeable battery unit for Cal. 3M6 Series is of a completely different type from the capacitor unit for Cal. 3M2 Series. They can be discriminated in the point that the former has a bend on its minus lead terminal while the latter doesn't as illustrated below. When repairing the rechargeable battery unit, check the bend on the minus lead terminal to make sure you are properly using a rechargeable battery unit.

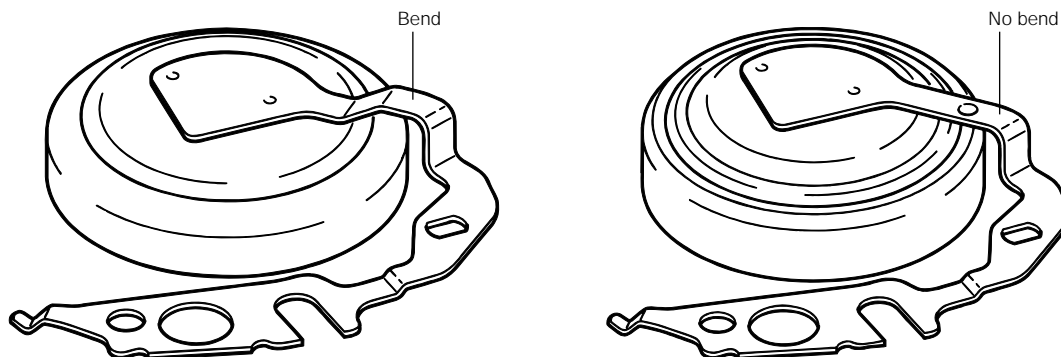

[Rechargeable battery unit for Cal. 3M6 Series]

[Capacitor unit for Cal. 3M2 Series]

- **How to install**

Set the guide hole of the minus lead terminal to the post of the main plate, and push the "A" portion down vertically so that the rechargeable battery unit is well seated in position.

Note: Take utmost care not to short-circuit the (+) and (-) terminals, as this will deteriorate the battery unit.

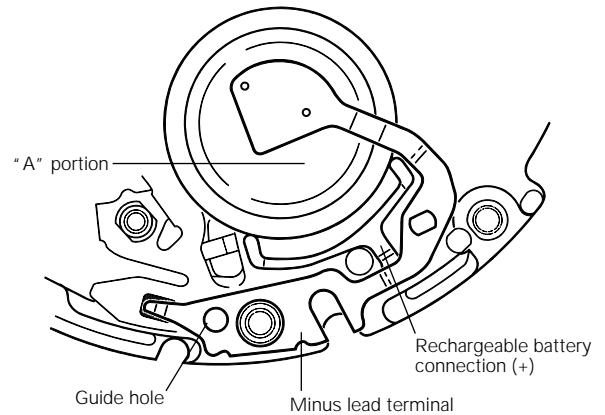

②③ Oscillating weight bridge

- **Lubricating**

Lubricate the ball-bearing of the oscillating weight bridge as shown in the illustration at right.

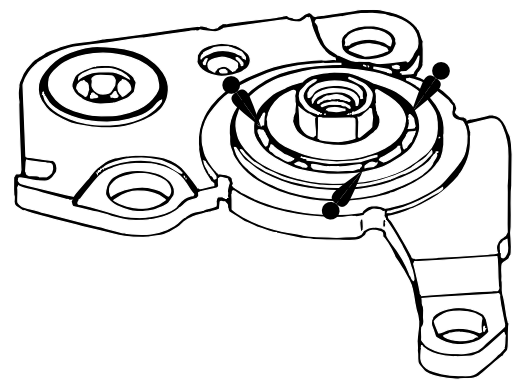

②④ Circuit block

The circuit block for Cal. 3M6 Series and that for Cal. 3M2 Series have a close resemblance in shape. They can be discriminated in the point that the circuit block for Cal. 3M6 Series has no diode element unlike that for Cal. 3M2 Series. When repairing the circuit block, check that it has no diode element to make sure you are using the proper one.

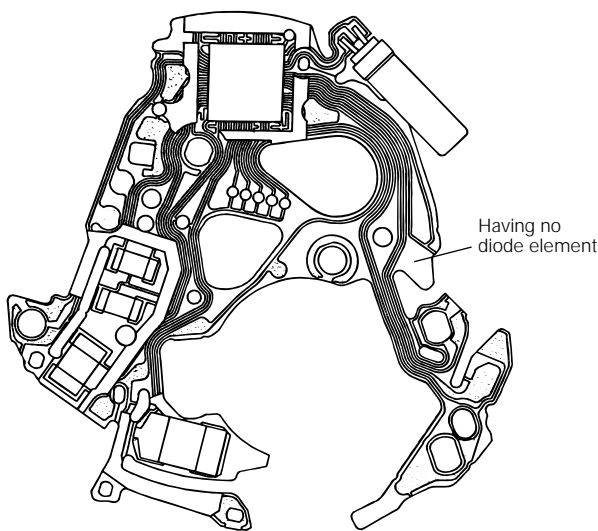

[Circuit block for Cal. 3M6 Series]

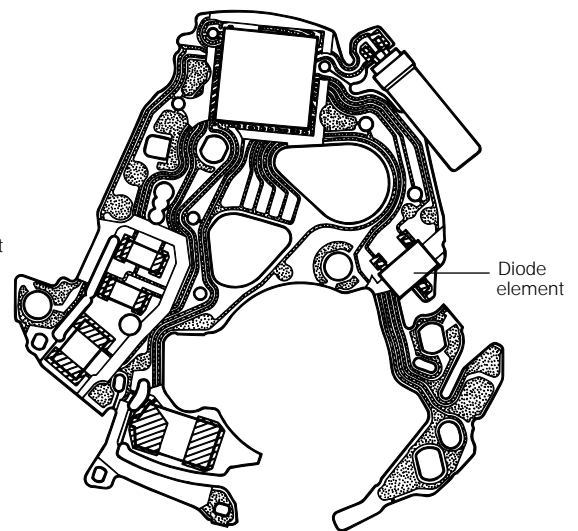

[Circuit block for Cal. 3M2 Series]

②⑤ Intermediate wheel for generating rotor

②⑥ Generating rotor

- Before tightening the oscillating weight bridge screw, check that the upper pivot of the generating rotor is inserted properly into the pivot jewel.
- Lubricate the generating rotor and intermediate wheel for generating rotor as shown in the illustration at right.

Note: Be sure to observe the position, type of oil and quantity of the lubrication specified in the illustration.

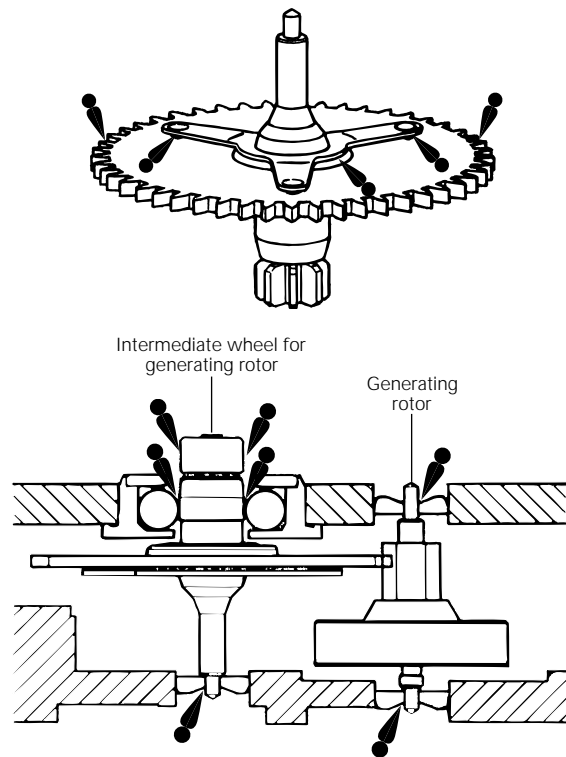

③① Fourth wheel and pinion

③② Fifth wheel and pinion

③③ Third wheel and pinion

③④ Minute wheel

③⑤ Setting wheel

③⑥ Step rotor

③⑦ Center wheel and pinion

• **Setting position and lubricating**

Refer to the illustrations below for the setting position and lubrication of the respective wheels.

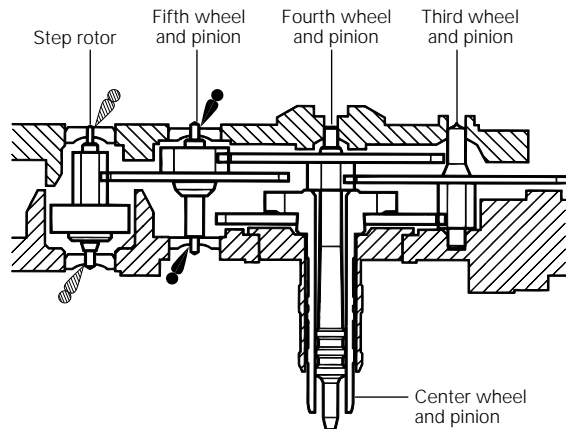
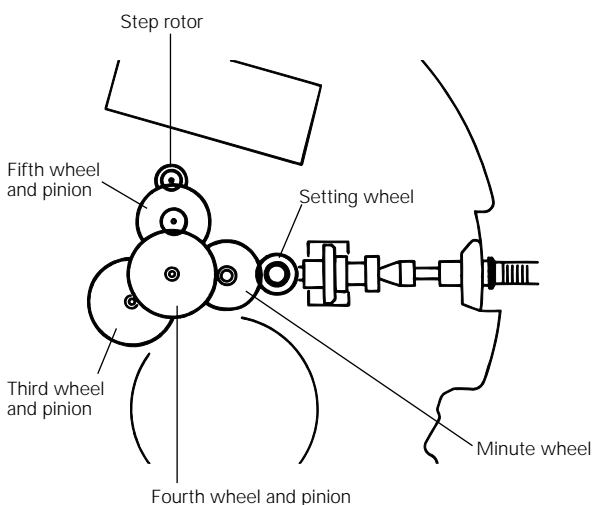

• **Lubricating**

Refer to the illustration at right.

Note: Be sure to observe the position, type of oil and quantity of the lubrication specified in the illustration.

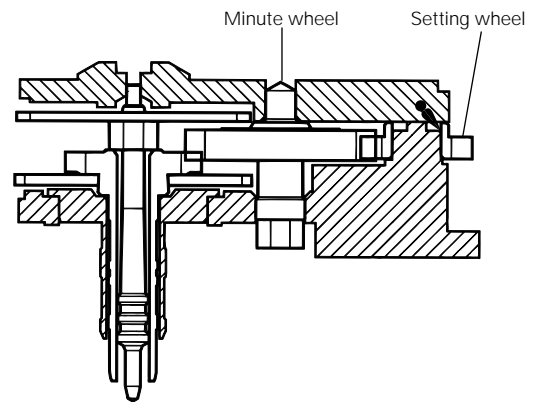

- ④④ Setting lever
- ④⑤ Yoke
- ④⑥ Train wheel setting lever

• **Setting position and lubricating**

Refer to the illustration at right.

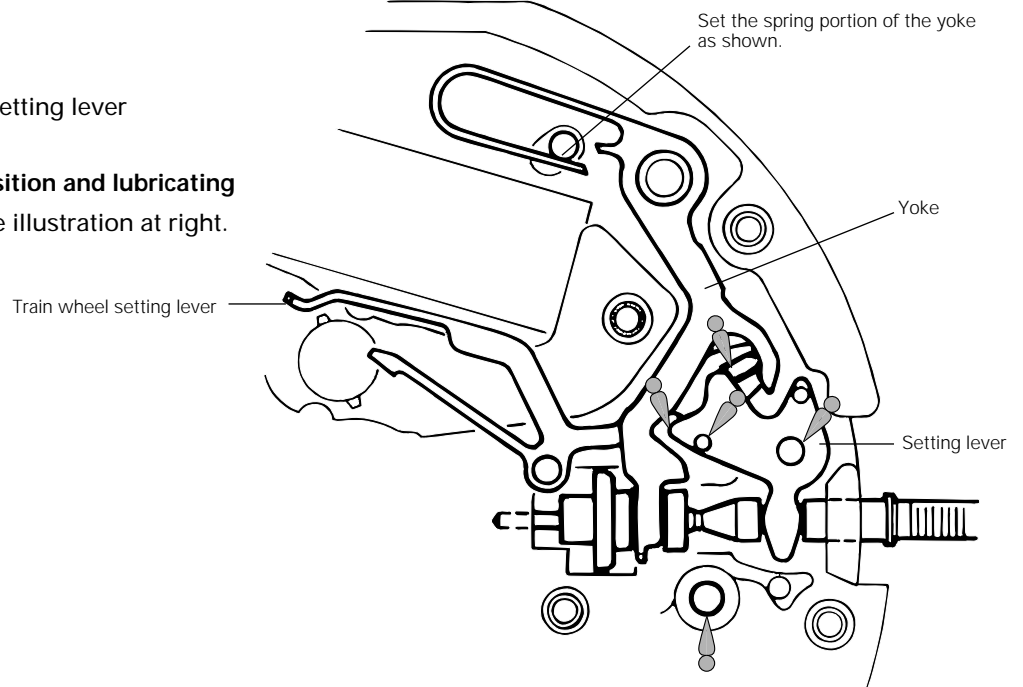

III. VALUE CHECKING AND ADJUSTMENT

● **Coil block resistance**

2.4 K Ω ~ 3.2 K Ω

● **Generating coil block resistance**

330 Ω ~ 430 Ω

● Current consumption

For the whole movement : Less than 0.60 μ A (with 1.55 V supplied from a battery)

For the circuit block alone : Less than 0.20 μ A (with 1.55 V supplied from a battery)

How to measure the current consumption for the whole movement

1. Make the movement ready for measurement.

- 1) Follow the disassembling procedure illustrated in this manual until you remove the rechargeable battery unit.
- 2) Install the rechargeable battery clamp and then tighten the screws "A" and "B" in the illustration at right.
- 3) Install the oscillating weight wheel and oscillating weight and then tighten the oscillating weight screw.

As a result, the insulators A and B for rechargeable battery, circuit block cover B screw, circuit block cover B and rechargeable battery unit are removed from the movement.

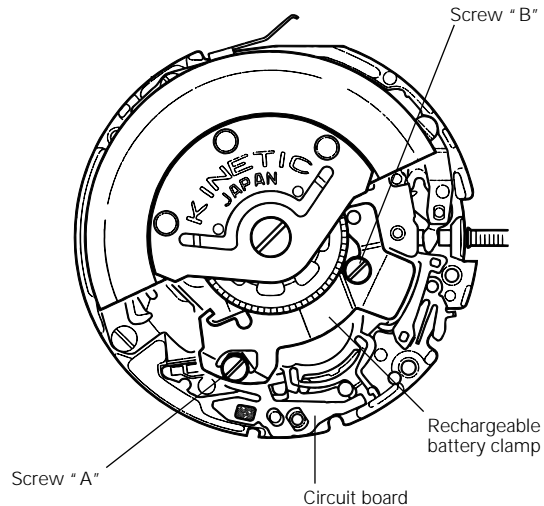

2. Apply the minus terminal to "a" portion of the input terminal (-) in the illustration and plus terminal to the rechargeable battery clamp, respectively.

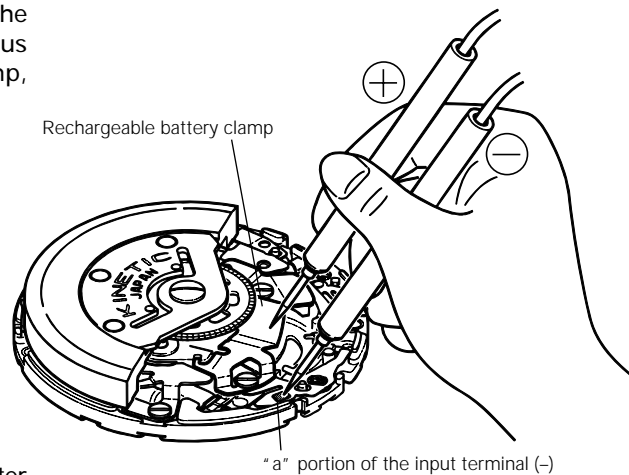

3. For a few seconds after the probes of the tester are applied to the movement, the IC is in the quick start mode, and current consumption cannot be measured properly. To switch the IC from the quick start to the normal hand movement mode, move the oscillating weight from side to side continuously for more than three seconds with the tester connected to the movement. The IC will detect the electricity generation and will be switched to the normal hand movement mode.

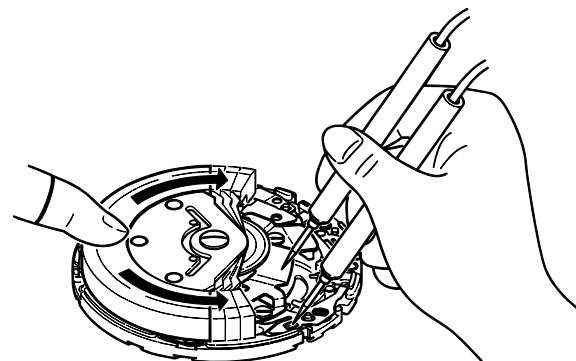

Note: When moving the oscillating weight from side to side, take care lest the minus terminal of the tester touches the oscillating weight.

4. After checking that the IC has been switched to the normal hand movement mode and a stable measurement can be obtained, read the measurement. If the measurement value remains high or unstable, repeat step "3" above.

Notes:

- * Light may increase the current consumption, resulting in an inaccurate measurement. If the current consumption exceeds the standard value, protect the movement from light with a black cloth or the like, and make a measurement again.
- * When the current consumption for the whole movement exceeds the standard value while the current consumption for the circuit block alone is within the standard value range, a driving pulse may be generated to compensate for the heavy load applied on the gear train, etc. In that case, overhaul and clean the movement parts, and then, measure the current consumption for the whole movement again.

How to measure the current consumption for the circuit block alone

1. Connect the tester to the circuit block as shown in the illustration.

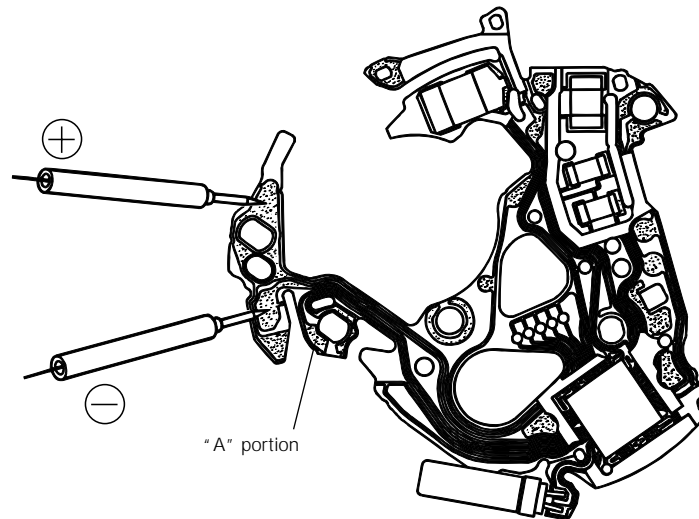

2. With the tester connected to the circuit block, short-circuit "A" portion in the illustration and the input terminal (-) with conductive tweezers or the like for more than 3 seconds. The IC will be switched from the quick start to the normal hand movement mode.
3. Checking that a stable measurement is obtained, read the current consumption. If the measurement value remains high or unstable, repeat step "2" above.

Note: The current consumption measurement for the circuit block alone is particularly susceptible to light, and a value higher than the actual measurement may be obtained if the circuit block is exposed to light. Protect the circuit from light with a black cloth or the like after following step "2" above, and then, measure the current consumption.

● **Checking the automatic generating system**

1. Apply the probes of the tester as shown in the illustration, and measure the voltage of the rechargeable battery. The obtained voltage is called the "initial voltage".

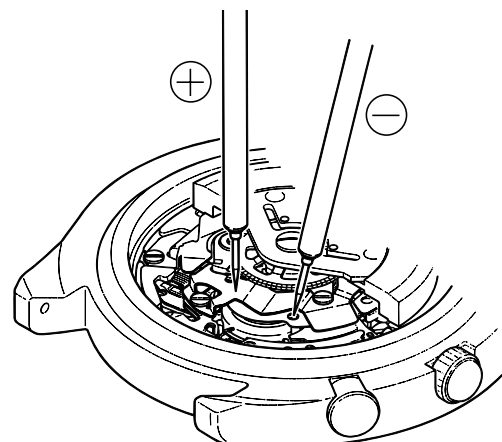

2. Close the case back tentatively, and swing the watch from side to side 200 times at a rate of 2 to 3 swings a second, making an arc of approximately 20 cm.

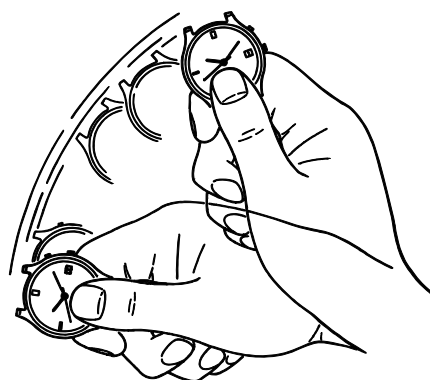

3. Within 3 minutes after swinging the watch, measure the voltage of the rechargeable battery in the same manner as in step "1" above.
4. If the voltage obtained has increased more than 0.04 V from the initial voltage assuming that the initial voltage is within the range between 0.5 V and 1.0 V, the automatic generating system is operating normally.

[For your information]

1. Number of swings and power reserve

- When the watch stops completely, swinging it approximately 400 times at a rate of 2 to 3 times a second will start the second hand moving at normal one-second intervals instead of two-second intervals, indicating that approximately one day of power has been reserved. If the second hand still moves at two-second intervals after 400 swings, swing the watch further until it moves at one-second intervals.
- While the second hand is moving at one-second intervals, 350 to 400 swings will reserve up to one day of power.

2. Power reserve indication and duration of charge until the watch stops operating

- Cal. 3M62A is equipped with a power reserve indicator. The current power reserve can be checked using the second hand at the press of the power reserve indicator button.

Quick movement of the second hand when the power reserve indicator function is activated	Duration of charge
5 seconds	Between 1 and 7 days
10 seconds	Between 7 days and 1 month
20 seconds	Approx. 1 month
30 seconds	Between 1.5 and 2 months

Note: Immediately after the watch is charged by swinging it from side to side, the indicator may show power reserve larger than the actual one. In that case, leave the watch untouched for 10 to 15 minutes, and then, check the power reserve.