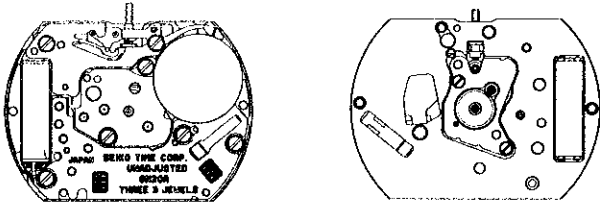

PARTS CATALOGUE/ TECHNICAL GUIDE

Cal. 8N20A

[SPECIFICATIONS]

Item		Cal. No.	8N20A
Movement		 <p>(x 1.5)</p>	
Movement size	Outside diameter	22.0mm between 6 o'clock and 12 o'clock sides 16.0mm between 3 o'clock and 9 o'clock sides	
	Casing diameter	φ21.6mm	
	Height	1.6mm	
Time indication		2 hands	
Driving system		Step rotor (Load compensated driving pulse type)	
Additional mechanism		<ul style="list-style-type: none"> • Electronic circuit reset switch • Train wheel setting device 	
Loss/gain		Monthly rate at normal temperature range: less than 15 seconds	
Regulation system		Pattern cutting system	
Measuring gate by quartz tester		Use 10-second gate.	
Battery		SEIKO SR716SW, Matsushita SR716SW Battery life is approximately 3 years. Voltage: 1.55V	
Jewels		3 jewels	

PARTS CATALOGUE

Cal. 8N20A

Disassembling procedures Figs.: (1) → (35)

Reassembling procedures Figs.: (35) → (1)

Lubricating: Types of oil

● Moebius A

○ SEIKO Watch Oil S-6

Oil quantity

○ Normal quantity

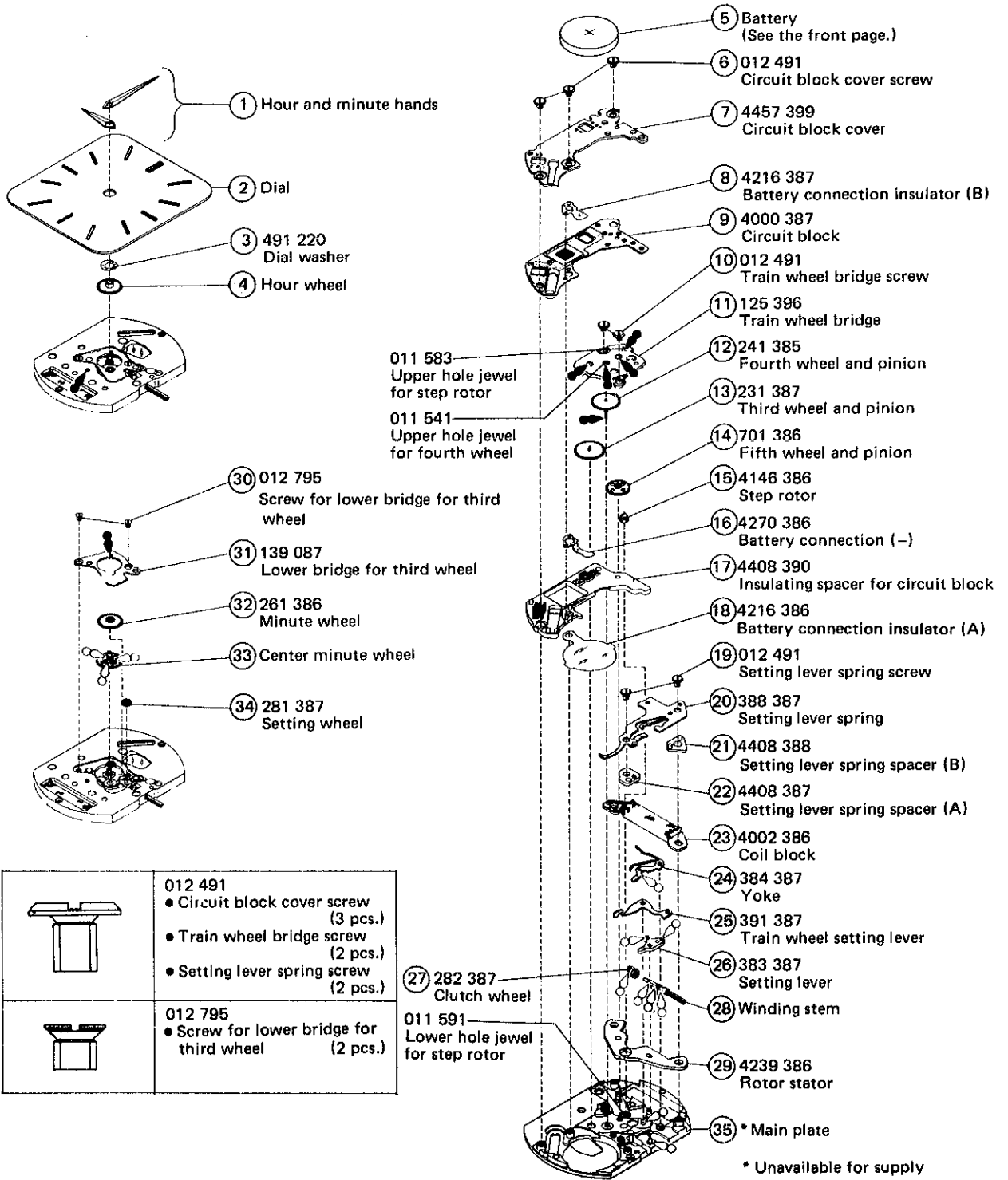

	012 491 ● Circuit block cover screw (3 pcs.) ● Train wheel bridge screw (2 pcs.) ● Setting lever spring screw (2 pcs.)
	012 795 ● Screw for lower bridge for third wheel (2 pcs.)



○ → Please see the remarks on the following pages.

* Unavailable for supply

Remarks:

- ④ Hour wheel 271 435
- ⑫ Fourth wheel and pinion 241 385
- ⑬ Center minute wheel 270 394

Combination:

Part name Type*	Fourth wheel and pinion	Hour wheel	Center minute wheel
L	 241 385	 271 435	 270 394

* Abbreviation : L . . . Long type
(Movement type)

Parts combination varies, depending on the design of cases. Refer to "SEIKO Casing Parts Catalogue".

- ⑳ Winding stem
351 387, 351 388

The type of winding stem is determined based on the design of cases. Check the case number and refer to "SEIKO Casing Parts Catalogue" to choose a corresponding winding stem.

• Other parts

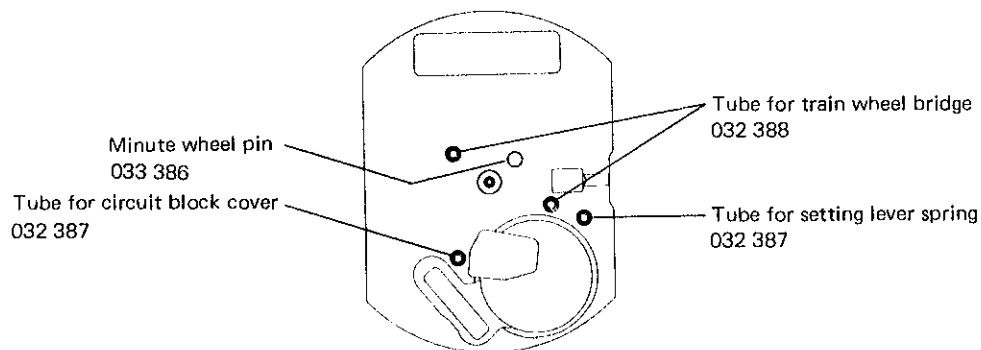

- The explanation here is only for particular points of Cal. 8N20A.
- For the repairing, checking and measuring procedures, refer to the "TECHNICAL GUIDE, GENERAL INSTRUCTIONS".

I. STRUCTURE OF THE CIRCUIT BLOCK

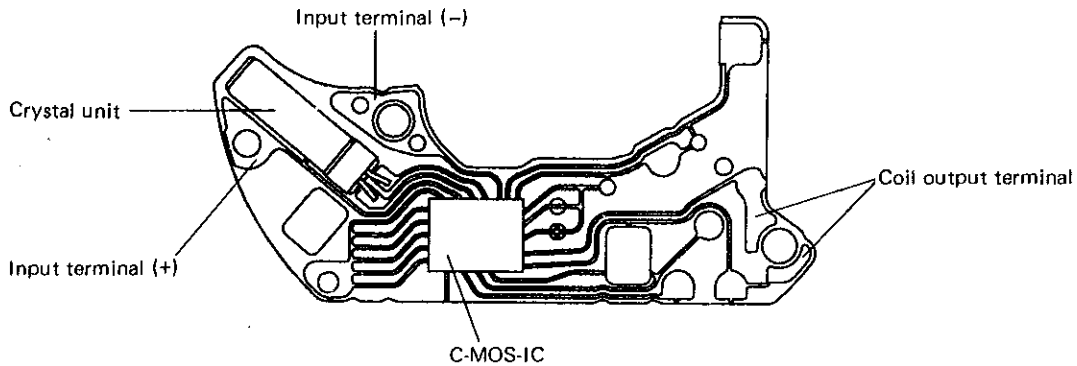

II. REMARKS ON DISASSEMBLING AND REASSEMBLING

11 Train wheel bridge

- **Setting position**

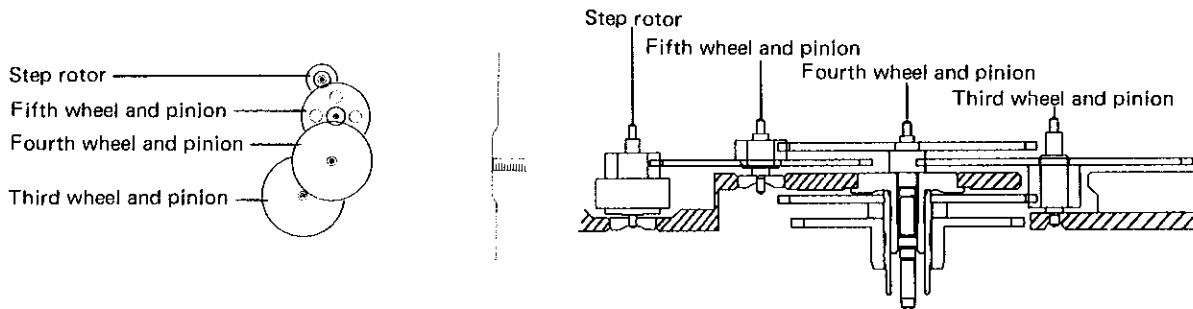

18 Battery connection insulator (A)

- **How to install**

Set battery connection insulator (A) to the main plate as indicated in the illustration at right, taking care not to set it upside down.

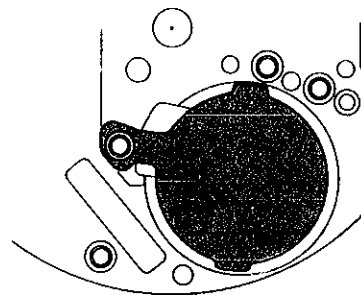

21 Setting lever spring spacer (B)

22 Setting lever spring spacer (A)

- **How to install**

Set spacers (A) and (B) to the main plate and setting lever spring, respectively before installing the setting lever spring, to facilitate the reassembling work.

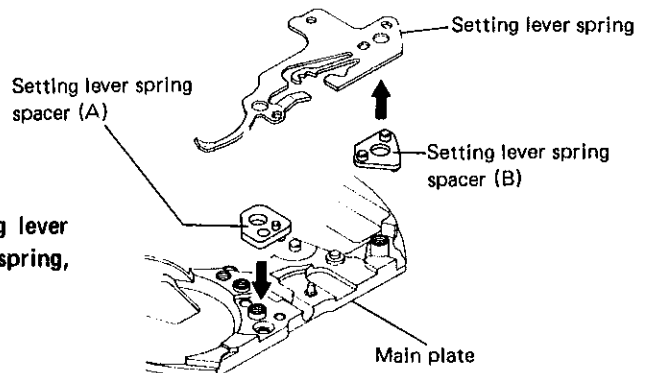

- ⑳ Setting lever spring
- ㉔ Yoke
- ㉕ Train wheel setting lever
- ㉖ Setting lever

● **Setting position**

Set the setting lever, train wheel setting lever and yoke in position in this order. Have the spring portion of the yoke catch the train wheel setting lever, and then install the setting lever spring, checking that the spring portion does not come off.

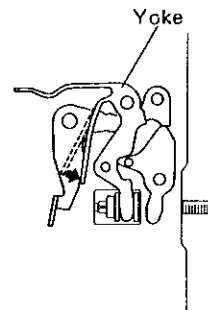

- ㉔ Setting wheel

● **How to install**

Set the setting wheel to the main plate with its gear portion down as shown in the illustration at right.

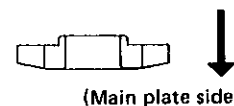
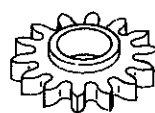

III. VALUE CHECKING

● **Coil block resistance**

3.4K Ω ~ 3.6K Ω

● **Current consumption**

For the whole of the movement: less than 0.8 μ A

For the circuit block alone : less than 0.3 μ A

Remarks:

When the current consumption exceeds the standard value for the whole of the movement but is less than the standard value for the circuit block alone, overhaul and clean the movement parts and then measure current consumption for the whole of the movement again. The driving pulse generated to compensate a heavy load that may apply on the gear train, etc. is considered to cause excessive current consumption for the whole of the movement.

● **Time accuracy**

To adjust time accuracy, cut the (+) or (-) pattern from the back side of the circuit block as indicated in the illustration at right.

(-) pattern: to lose approximately 0.26 sec./day

(+) pattern: to gain approximately 0.26 sec./day

Note: After cutting the pattern, remove the sludge completely.

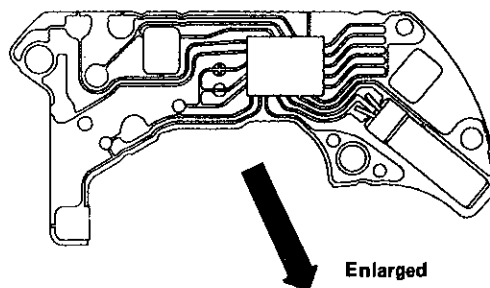

Enlarged

